

Instructor's Solutions Manual

to accompany

Design of Concrete Structures, 14e

Nilson/Darwin/Dolan

The authors welcome feedback on the problem solutions and on the text in general. Please e-mail any comments to David Darwin at: daved@ku.edu

PROPRIETARY AND CONFIDENTIAL

This Manual is the proprietary property of The McGraw-Hill Companies, Inc. ("McGraw-Hill") and protected by copyright and other state and federal laws. By opening and using this Manual the user agrees to the following restrictions, and if the recipient does not agree to these restrictions, the Manual should be promptly returned unopened to McGraw-Hill: This Manual is being provided only to authorized professors and instructors for use in preparing for the classes using the affiliated textbook. No other use or distribution of this Manual is permitted. This Manual may not be sold and may not be distributed to or used by any student or other third party. No part of this Manual may be reproduced, displayed or distributed in any form or by any means, electronic or otherwise, without the prior written permission of the McGraw-Hill.

$$1.1 \quad A_s = 6.0 \text{ in}^2$$

$$f_y = 40,000 \text{ psi}$$

$$E_s = 29,000,000 \text{ psi}$$

$$n = \frac{29,000,000}{3,600,000} = 8$$

$$A_g = 16 \times 20 = 320 \text{ in}^2$$

$$A_c = 320 - 6 = 314 \text{ in}^2$$

$$f_c' = 4,000 \text{ psi}$$

$$E_c = 3,600,000$$

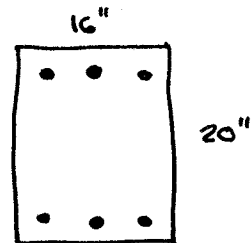

$$a) \quad f_c = 1200 \text{ psi}, \quad f_y = 40,000 \text{ psi}$$

$$P = 1200(314 + 8 \times 6) \\ = 434,000 \text{ lbs}$$

$$P_s = 1200(8 \times 6) = 57,600 \text{ lbs}$$

$$P_s = 13.3\% \text{ of } P$$

$$b) \quad \epsilon_y = \frac{40,000}{29,000,000} = 0.00140$$

$$\text{for slow loading } f_c = 3000 \text{ psi}$$

$$P = 3000(314) + 40,000(6) \\ = 1,182,000 \text{ lbs}$$

$$P_s = 40,000(6) = 240,000 \text{ lb} \\ = 20.3\% P$$

$$c) \quad f_c = 3400 \text{ psi}$$

$$P_u = 3400(314) + 40,000(6) \\ = 1,308,000 \text{ lb}$$

$$P_s = 240,000 \text{ lb} \quad (18.3\% P_u)$$

$$a) \quad f_y = 60,000 \text{ psi} \\ \text{Same}$$

$$\epsilon_y = \frac{60,000}{29,000,000} = 0.00207$$

$$f_c = 3300 \text{ psi}$$

$$P = 3300(314) + 60,000(6) \\ = 1,396,000 \text{ lbs}$$

$$P_s = 60,000(6) = 360,000 \text{ lb} \\ = 25.6\% P$$

$$P_u = 3400(314) + 60,000(6) \\ = 1,428,000 \text{ lb}$$

$$P_s = 360,000 \text{ lb} \quad (25.2\% P_u)$$

Comments:

1. There is no difference in performance at $f_c = 1200 \text{ psi}$
2. As the strain increases, the steel with $f_y = 60,000 \text{ psi}$ contributes more to the total load and the column has a higher total load.
3. For the same cost, $f_y = 60,000 \text{ psi}$ provides a 9% increase in capacity.

1.2

$$A_s = 8(1.56) = 12.48 \text{ in}^2$$

$$A_g = 320 \text{ in}^2 \quad A_c = 307.5 \text{ in}^2$$

$$n = 8 \quad E_s = 29,000,000 \text{ psi}$$

$$E_c = 3,600,000 \text{ psi}$$

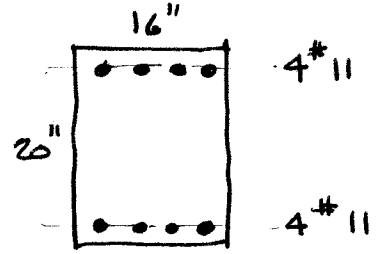

$$f_y = 60,000 \text{ psi}$$

a)

$$P = 1200(307.5 + 8(12.48)) =$$

$$= 489,000 \text{ lb}$$

$$P_s = 1200(8)(12.48) = 120,000 \text{ lb}$$

$$(24.5\% P)$$

• Same as $f_y = 40,000$

b)

$$e_y = 0.00140, \quad f_c = 3000 \text{ psi}$$

$$P = 3000(307.5) + 40,000(12.48)$$

$$= 1,424,000 \text{ lb}$$

$$P_s = 40,000(12.48) = 500,000 \text{ lb}$$

$$(35.1\% \text{ of } P)$$

$$e_y = 0.00207 \quad f_c = 3300 \text{ psi}$$

$$P = 3300(307.5) + 60,000(12.48)$$

$$= 1,766,000 \text{ lb}$$

$$P_s = 60,000(12.48) = 750,000$$

$$(42.5\% \text{ of } P)$$

c)

$$f_c = 3400 \text{ psi} \text{ both cases}$$

$$P_0 = 3400(307.5) + 40,000(12.48)$$

$$= 1,547,000 \text{ lb}$$

$$P_s = 500,000 \text{ lb}$$

$$(32.3\% \text{ of } P_0)$$

$$P_0 = 3400(307.5) + 60,000(12.48)$$

$$= 1,797,000 \text{ lb}$$

$$P_s = 750,000 \text{ lb}$$

$$(41.7\% \text{ of } P_0)$$

Comments

1. There is no strength difference at $f_c = 1200 \text{ psi}$
2. There is a 16% strength increase at ultimate using $f_y = 60,000 \text{ psi}$, This occurs at virtually no cost increase
3. The higher steel ratio produces a stronger column - compare to prob. 1.1

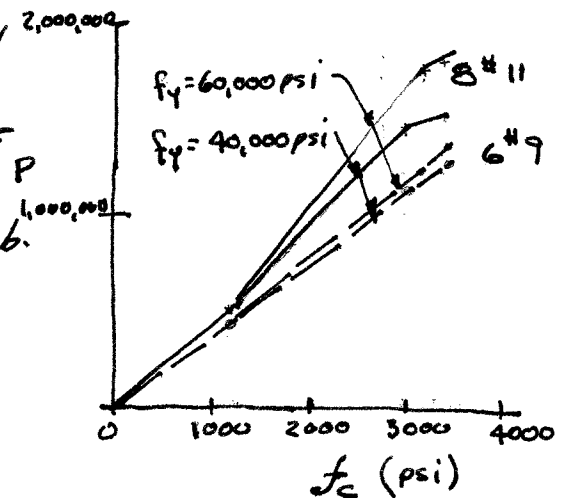

1.3

$A_s = 10.12 \text{ in}^2$
 $A_c = 474 \text{ in}^2$
 $f_y = 60000 \text{ psi}$
 $f'_c = 4000 \text{ psi}$

$\epsilon_c = \epsilon_s$	f_c (psi)	P_c (kips)	f_s (psi)	P_s (kips)	P_{total} (kips)	P_c/P_{total}	P_s/P_{total}
0	0	0	0	0	0	85.0%	15.0%
0.0005	1600	758.4	15000	151.8	910.2	83.3%	16.7%
0.001	2600	1232.4	30000	303.6	1536	80.2%	19.8%
0.0015	3100	1469.4	45000	455.4	1924.8	76.3%	23.7%
0.002	3300	1564.2	57000	576.84	2141.04	73.1%	26.9%
0.0025	3400	1611.6	60000	607.2	2218.8	72.6%	27.4%
0.003	3400	1611.6	60000	607.2	2218.8	72.6%	27.4%

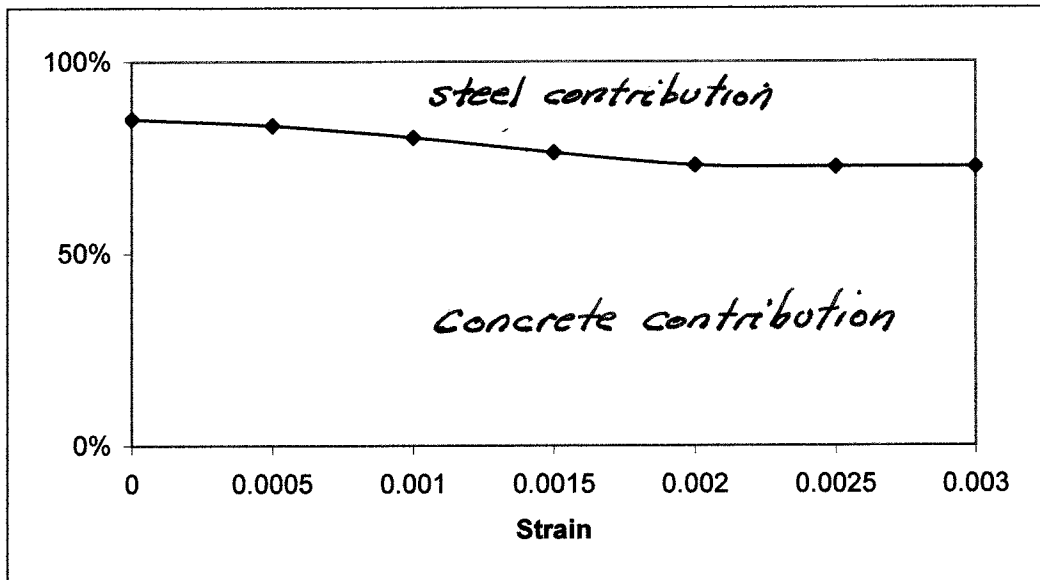

1.4 A 20 x 24 in. column is made of the same concrete as Examples 1.1 and 1.2 but reinforced with six No. 11 (No. 36) bars with $f_y = 60$ ksi. For this column section, determine (a) the axial load the section will carry at a concrete stress of 1400 psi, (b) the load on the section when the steel begins to yield, (c) the maximum load if the section is loaded slowly and (d) the maximum load if the section is loaded rapidly. The area of one No. 11 (No. 36) bar is 1.56 in^2 . Determine the percent of the load carried by the steel and the concrete for each combination.

▣ Reinforcement Areas

Given Properties

$$f_c := 4000 \text{ psi} \quad f_y := 60000 \text{ psi} \quad f_c := 1400 \text{ psi} \quad n := 8 \quad E_s := 29000000 \text{ psi}$$

Column Properties

$$b := 20 \text{ in} \quad h := 24 \text{ in} \quad A_{st} := 6 \cdot A_{s11} = 9.36 \text{ in}^2 \quad \text{The total area of steel } A_{st} \text{ is six no. 11 bars}$$

Part (a) Compute the axial capacity of the section loaded below the elastic limit.

Solution: The axial capacity is based on the gross area of the column plus the effective area of the steel. Since we count the holes where the steel is removed, the additional effective area of the steel is $(n-1)A_{st}$.

$$A_g := b \cdot h \quad A_g = 480 \text{ in}^2 \quad A_{st} = 9.36 \text{ in}^2 \quad \text{Reinforcement ratio} = \frac{A_{st}}{A_g} = 0.0195$$

$$P := f_c \cdot [A_g + (n - 1) \cdot A_{st}] \quad P = 764 \text{ kip}$$

$$P_c := f_c \cdot (A_g - A_{st}) \quad P_c = 659 \text{ kip}$$

$$P_s := f_c \cdot n \cdot A_{st} \quad P_s = 105 \text{ kip} \quad 100 \cdot \frac{P_c}{P} = 86.3 \quad 100 \cdot \frac{P_s}{P} = 13.7$$

Part (b): Compute the capacity of the column when the steel begins to yield $\epsilon := 0.002069$ or 2/10 of one percent

Examining Figure 1.16, we are **beyond the elastic portion of the concrete** stress strain curve, but we are at the elastic limit of the steel.

$$f_s := \epsilon \cdot E_s \quad f_s = 60001 \text{ psi}$$

$$\text{From Figure 1.16} \quad f_c := 3100 \text{ psi} \quad \text{for slow loading}$$

Since the problem is nonlinear, we must break out the concrete and steel areas. We can no longer use the elastic equation from 1.1.

$$A_c := A_g - A_{st}$$

$$P := f_c \cdot A_c + f_s \cdot A_{st} \quad P = 2021 \text{ kip}$$

$$P_c := f_c \cdot A_c \quad P_c = 1459 \text{ kip}$$

$$P_s := f_s \cdot A_{st} \quad P_s = 562 \text{ kip} \quad 100 \cdot \frac{P_c}{P} = 72.2 \quad 100 \cdot \frac{P_s}{P} = 27.8$$

Part (c): Compute the maximum load capacity of the section

Examining Figure 1.16, we are **beyond the elastic portion of the concrete** stress strain curve, but we are in the plastic range of the steel.

$$f_s := f_y$$

From Figure 1.16

Since the problem is nonlinear, we must break out the concrete and steel areas. We can no longer use the elastic equation from 1.1.

$$f_s = 60000 \text{ psi}$$

$$f_c := 3400 \text{ psi} \quad \text{for slow loading}$$

$$A_c := A_g - A_{st}$$

$$P := f_c \cdot A_c + f_s \cdot A_{st} \quad P = 2162 \text{ kip}$$

$$P_c := f_c \cdot A_c \quad P_c = 1600 \text{ kip}$$

$$P_s := f_s \cdot A_{st} \quad P_s = 562 \text{ kip} \quad 100 \cdot \frac{P_c}{P} = 74.0 \quad 100 \cdot \frac{P_s}{P} = 26.0$$

If we reexamine the problem with a fast loading as would occur in a building, then the concrete stress would be

$$f_c := 4000 \text{ psi}$$

$$P := f_c \cdot A_c + f_s \cdot A_{st} \quad P = 2444 \text{ kip}$$

$$P_c := f_c \cdot A_c \quad P_c = 1883 \text{ kip} \quad 100 \cdot \frac{P_c}{P} = 77.0$$

$$P_s := f_s \cdot A_{st} \quad P_s = 562 \text{ kip} \quad 100 \cdot \frac{P_s}{P} = 23.0$$

Comments

1. As the concrete becomes non-linear, the steel picks up more load, but after the steel yields, the load goes to the concrete.
2. The slow loading is approximately 88% of the fast load scenario

1.5 A 24 in. diameter column is made of the same concrete as Examples 1.1 and 1.2. The area of reinforcement equals 2.1 percent of the gross cross section (i.e., $A_s = 0.021A_g$) and $f_y = 60$ ksi. For this column section, determine (a) the axial load the section will carry at a concrete stress of 1200 psi, (b) the load on the section when the steel begins to yield, (c) the maximum load if the section is loaded slowly, (d) the maximum load if the section is loaded rapidly and (e) the maximum load the reinforcement in the column is raised to 6.5 percent and the column is loaded slowly. Comment on your answer, especially the percent of the load carried by the steel and the concrete for each combination.

Given Properties

$$f_c := 4000\text{psi} \quad f_y := 60000\text{psi} \quad f_c := 1200\text{psi} \quad n := 8 \quad E_s := 29000000\text{psi}$$

Column Properties

$$d := 24\text{in} \quad A_g := \pi \cdot \frac{d^2}{4} \quad \rho := 0.021 \quad \rho \text{ is the reinforcement ratio or the fraction of the section that is steel}$$

$$A_{st} := \rho \cdot A_g \quad \text{The total area of steel } A_{st} \text{ is } A_{st} = 9.5 \text{ in}^2$$

Part (a) Compute the axial capacity of the section loaded below the elastic limit.

Solution: The axial capacity is based on the gross area of the column plus the effective area of the steel. Since we count the holes where the steel is removed, the additional effective area of the steel is $(n-1)A_{st}$.

$$\begin{aligned} A_c &:= A_g - A_{st} & A_g &= 452 \text{ in}^2 & A_{st} &= 9.50 \text{ in}^2 & A_c &= 443 \text{ in}^2 \\ P &:= f_c \cdot [A_g + (n-1) \cdot A_{st}] & P &= 623 \text{ kip} & & & \text{Concrete and steel contribution} \\ P_c &:= f_c \cdot (A_g - A_{st}) & P_c &= 531 \text{ kip} & & & 100 \cdot \frac{P_c}{P} = 85.4 \\ P_s &:= f_c \cdot n \cdot A_{st} & P_s &= 91 \text{ kip} & & & 100 \cdot \frac{P_s}{P} = 14.6 \end{aligned}$$

Part (b): Compute the capacity of the column when the steel begins to yield $\epsilon_y := \frac{f_y}{E_s}$

$$\epsilon_y = 0.00207 \quad \text{or } 2/10 \text{ of one percent}$$

Examining Figure 1.16, we are **beyond the elastic portion of the concrete stress strain curve**, but we are at the elastic limit of the steel.

$$f_s := \epsilon_y \cdot E_s \quad f_s = 60000 \text{ psi}$$

From Figure 1.16 $f_c := 3100\text{psi}$ for slow loading

Since the problem is nonlinear, we must break out the concrete and steel areas. We can no longer use the elastic equation from 1.1.

$$\begin{aligned} P &:= f_c \cdot A_c + f_s \cdot A_{st} & P &= 1943 \text{ kip} & & & \\ P_c &:= f_c \cdot A_c & P_c &= 1373 \text{ kip} & & & 100 \cdot \frac{P_c}{P} = 27.4 \\ P_s &:= f_s \cdot A_{st} & P_s &= 570 \text{ kip} & & & 100 \cdot \frac{P_s}{P} = 29.3 \end{aligned}$$

Part (c): Compute the maximum load capacity of the section if loaded slowly

Examining Figure 1.16, we are **beyond the elastic portion of the concrete stress strain curve**

and we are in the plastic range of the steel.

$$f_s := f_y$$

$$f_s = 60000 \text{ psi}$$

From Figure 1.16

$$f_c := 3400 \text{ psi} \quad \text{for slow loading}$$

Since the problem is nonlinear, we must break out the concrete and steel areas. We can no longer use the elastic equation from 1.1:

$$P := f_c \cdot A_c + f_s \cdot A_{st}$$

$$P = 2076 \text{ kip}$$

$$P_c := f_c \cdot A_c$$

$$P_c = 1506 \text{ kip}$$

$$100 \cdot \frac{P_c}{P} = 72.5$$

$$P_s := f_s \cdot A_{st}$$

$$P_s = 570 \text{ kip}$$

$$100 \cdot \frac{P_s}{P} = 27.5$$

Part (d): If we reexamine the problem with a fast loading as would occur in a building, then the concrete stress would be

$$f_c := 4000 \text{ psi}$$

$$P := f_c \cdot A_c + f_s \cdot A_{st}$$

$$P = 2342 \text{ kip}$$

$$P_c := f_c \cdot A_c$$

$$P_c = 1772 \text{ kip}$$

$$100 \cdot \frac{P_c}{P} = 75.7 \quad 100 \cdot \frac{P_s}{P} = 24.3$$

$$P_s := f_s \cdot A_{st}$$

$$P_s = 570 \text{ kip}$$

Part (e): Determine the capacity for a slow loaded column with the steel changed to 6.5%

$$A_{st} := 0.065 \cdot A_g$$

$$A_{st} = 29.4 \text{ in}^2$$

$$f_s := f_y$$

$$f_s = 60000 \text{ psi}$$

From Figure 1.16

$$f_c := 3400 \text{ psi} \quad \text{for slow loading}$$

$$P := f_c \cdot A_c + f_s \cdot A_{st}$$

$$P = 3270 \text{ kip}$$

$$P_c := f_c \cdot A_c$$

$$P_c = 1506 \text{ kip}$$

$$100 \cdot \frac{P_c}{P} = 46.0$$

$$P_s := f_s \cdot A_{st}$$

$$P_s = 1764 \text{ kip}$$

$$100 \cdot \frac{P_s}{P} = 54.0$$

Comments

1. As the concrete becomes non-linear, the steel picks up more load, but after the steel yields, the load goes to the concrete.
2. The slow loading is approximately 88% of the fast load scenario - This is slightly higher than the 0.85 given in eq. 1.8.

1.5 A 24 in. diameter column is made of the same concrete as Examples 1.1 and 1.2. The area of reinforcement equals 2.1 percent of the gross cross section (i.e., $A_s = 0.021A_g$) and $f_y = 60$ ksi. For this column section, determine (a) the axial load the section will carry at a concrete stress of 1200 psi, (b) the load on the section when the steel begins to yield, (c) the maximum load if the section is loaded slowly, (d) the maximum load if the section is loaded rapidly and (e) the maximum load the reinforcement in the column is raised to 6.5 percent and the column is loaded slowly. Comment on your answer, especially the percent of the load carried by the steel and the concrete for each combination.

Given Properties

$$f_c := 4000\text{psi} \quad f_y := 60000\text{psi} \quad f_c := 1200\text{psi} \quad n := 8 \quad E_s := 29000000\text{psi}$$

Column Properties

$$d := 24\text{in} \quad A_g := \pi \frac{d^2}{4} \quad \rho := 0.021 \quad \rho \text{ is the reinforcement ratio or the fraction of the section that is steel}$$

$$A_{st} := \rho A_g \quad \text{The total area of steel } A_{st} \text{ is } A_{st} = 9.5\text{in}^2$$

Part (a) Compute the axial capacity of the section loaded below the elastic limit.

Solution: The axial capacity is based on the gross area of the column plus the effective area of the steel. Since we count the holes where the steel is removed, the additional effective area of the steel is $(n-1)A_{st}$.

$$A_c := A_g - A_{st} \quad A_g = 452\text{in}^2 \quad A_{st} = 9.50\text{in}^2 \quad A_c = 443\text{in}^2$$

$$P := f_c [A_g + (n-1)A_{st}] \quad P = 623\text{kip} \quad \text{Concrete and steel contribution}$$

$$P_c := f_c (A_g - A_{st}) \quad P_c = 531\text{kip} \quad 100 \cdot \frac{P_c}{P} = 85.4$$

$$P_s := f_c \cdot n \cdot A_{st} \quad P_s = 91\text{kip} \quad 100 \cdot \frac{P_s}{P} = 14.6$$

Part (b): Compute the capacity of the column when the steel begins to yield $\epsilon_y := \frac{f_y}{E_s}$

$$\epsilon_y = 0.00207 \quad \text{or } 2/10 \text{ of one percent}$$

Examining Figure 1.16, we are **beyond the elastic portion of the concrete stress strain curve**, but we are at the elastic limit of the steel.

$$f_s := \epsilon_y \cdot E_s \quad f_s = 60000\text{psi}$$

From Figure 1.16 $f_{s,max} := 3100\text{psi}$ for slow loading

Since the problem is nonlinear, we must break out the concrete and steel areas. We can no longer use the elastic equation from 1.1.

$$P_{max} := f_c A_c + f_s A_{st} \quad P = 1943\text{kip} \quad 100 \cdot \frac{P_c}{P} = 27.4$$

$$P_{c,max} := f_c A_c \quad P_c = 1373\text{kip}$$

$$P_{s,max} := f_s A_{st} \quad P_s = 570\text{kip} \quad 100 \cdot \frac{P_s}{P} = 29.3$$

Part (c): Compute the maximum load capacity of the section if loaded slowly

Examining Figure 1.16, we are **beyond the elastic portion of the concrete stress strain curve**

and we are in the plastic range of the steel.

$$f_{\max} := f_y$$

$$f_s = 60000 \text{ psi}$$

From Figure 1.16

$$f_{\max} := 3400 \text{ psi for slow loading}$$

Since the problem is nonlinear, we must break out the concrete and steel areas. We can no longer use the elastic equation from 1.1.

$$P_{\max} := f_c \cdot A_c + f_s \cdot A_{st}$$

$$P = 2076 \text{ kip}$$

$$P_{\max} := f_c \cdot A_c$$

$$P_c = 1506 \text{ kip}$$

$$100 \cdot \frac{P_c}{P} = 72.5$$

$$P_{\max} := f_s \cdot A_{st}$$

$$P_s = 570 \text{ kip}$$

$$100 \cdot \frac{P_s}{P} = 27.5$$

Part (d): If we reexamine the problem with a fast loading as would occur in a building, then the concrete stress would be

$$f_{\max} := 4000 \text{ psi}$$

$$P_{\max} := f_c \cdot A_c + f_s \cdot A_{st}$$

$$P = 2342 \text{ kip}$$

$$P_{\max} := f_c \cdot A_c$$

$$P_c = 1772 \text{ kip}$$

$$100 \cdot \frac{P_c}{P} = 75.7 \quad 100 \cdot \frac{P_s}{P} = 24.3$$

$$P_{\max} := f_s \cdot A_{st}$$

$$P_s = 570 \text{ kip}$$

Part (e): Determine the capacity for a slow loaded column with the steel changed to 6.5%

$$A_{\max} := 0.065 \cdot A_g$$

$$A_{st} = 29.4 \text{ in}^2$$

$$f_{\max} := f_y$$

$$f_s = 60000 \text{ psi}$$

From Figure 1.16

$$f_{\max} := 3400 \text{ psi for slow loading}$$

$$P_{\max} := f_c \cdot A_c + f_s \cdot A_{st}$$

$$P = 3270 \text{ kip}$$

$$P_{\max} := f_c \cdot A_c$$

$$P_c = 1506 \text{ kip}$$

$$100 \cdot \frac{P_c}{P} = 46.0$$

$$P_{\max} := f_s \cdot A_{st}$$

$$P_s = 1764 \text{ kip}$$

$$100 \cdot \frac{P_s}{P} = 54.0$$

Comments

1. As the concrete becomes non-linear, the steel picks up more load, but after the steel yields, the load goes to the concrete.
2. The slow loading is approximately 88% of the fast load scenario - This is slightly higher than the 0.85 given in eq. 1.8.

2.1

$$f'_c = 6000 \text{ psi}$$

(a) No prior results

$$f'_{cr} = f'_c + 0.1 f'_c + 700 \text{ psi} = 6000 + 0.1 \times 6000 + 700 = 7300 \text{ psi}$$

(b) 20 prior tests for concrete with f'_c within

1000 psi of f'_c for project. $s_s = 580 \text{ psi}$ -

$$\text{From Table 1.1, } 1.08 \times 580 = 626 \text{ psi}$$

Because $f'_c > 5000 \text{ psi}$, use Eqs. (2.1) + (2.2b)

$$f'_{cr} = f'_c + 1.34 s_s = 6000 + 1.34 \times 626 = 6840 \text{ psi}$$

$$f'_{cr} = 0.9 f'_c + 2.33 s_s = 0.9 \times 6000 + 2.33 \times 626 = 6860 \text{ psi}$$

Use $f'_{cr} = 6860 \text{ psi}$

(c) 30 prior tests for concrete with f'_c within

1000 psi of f'_c for project. $s_s = 590 \text{ psi}$ -

$$f'_{cr} = f'_c + 1.34 s_s = 6000 + 1.34 \times 590 = 6790 \text{ psi}$$

$$f'_{cr} = 0.9 f'_c + 2.33 s_s = 0.9 \times 6000 + 2.33 \times 590 = 6770 \text{ psi}$$

Use $f'_{cr} = 6790 \text{ psi}$

2.2

(a) For $f'_c = 4000 \text{ psi}$, the strength results indicate satisfactory concrete quality because (1) no individual test is below $f'_c - 500 \text{ psi} = 3500 \text{ psi}$, and (2) every arithmetic average of any three consecutive tests equals or exceeds f'_c .

(b) For $S_s = 510 \text{ psi}$ for 30 consecutive tests,

calculate f'_{cr} using Eqs (2.1) and (2.2a)

$$f'_{cr} = f'_c + 1.34S_s = 4000 + 1.34 \times 510 = 4680 \text{ psi}$$

$$f'_{cr} = f'_c + 2.33S_s - 500 \text{ psi} = 4000 + 2.33 \times 510 - 500 \\ = 4690 \text{ psi}$$

Use 4690 psi

$$(4590 + 4750 + 5280 + 4210 + 4460 + 4170 + 3750 + 5110 + 4640 + 4170) / 10 \\ = 4510 < f'_{cr}$$

Because the average compressive strength is less than f'_{cr} , the water-cement ratio must be decreased, either by adding cement or reducing water, to increase strength. If the water is reduced, a water reducer must be added or the quantity of water reducer must be increased to maintain concrete workability.

Problem 3.1 A rectangular beam made using concrete with $f'_c = 6000$ psi and steel with $f_y = 60,000$ psi had a width $b = 20$ in., and an effective depth of $d = 17.5$ in and an $h = 20$ in. The Concrete modulus of rupture $f_r = 530$ psi. The elastic modulus of the steel and concrete are, respectively $E_c = 4,030,000$ psi and $E_s = 29,000,000$ psi. The area of steel is four No. 11 (No. 36) bars.

- (a) Find the maximum service load that can be resisted without stressing the concrete above $0.45 f'_c$ or the steel above $0.40 f_y$.
- (b) Determine if the beam will show cracking before reaching the service load
- (c) Compute the nominal moment capacity of the beam
- (d) Compute the ratio of the nominal capacity of the beam to the maximum service level capacity and compare your findings to the ACI load factors and strength reduction factor.

▣ Reinforcement sizes

Given data

Note: for all MathCAD based solutions, the area and diameter of reinforcement bars is in a common database. Hence the notation A_{s11} indicates the area of a single No. 11 (No. 36) bar.

$$A_s := 4 \cdot A_{s11} \quad A_s = 6.24 \text{ in}^2 \quad E_s := 29000000 \text{ psi}$$

$$b := 20 \text{ in} \quad d := 17.5 \text{ in} \quad h := 20 \text{ in}$$

$$f'_c := 6000 \text{ psi} \quad f_y := 60000 \text{ psi} \quad E_c := 57000 \sqrt{f'_c} \text{ psi} \quad E_c = 4415 \text{ ksi}$$

$$f_r := 7.5 \sqrt{f'_c} \text{ psi} \quad f_r = 581 \text{ psi} \quad n := \frac{E_s}{E_c} \quad n = 6.6$$

- (a) Find the maximum service load that can be resisted without stressing the concrete above $0.45 f'_c$ or the steel above $0.40 f_y$.

$$f_c := 0.45 f'_c \quad f_c = 2700 \text{ psi}$$

$$f_s := 0.40 f_y \quad f_s = 36000 \text{ psi}$$

$$\rho := \frac{A_s}{b \cdot d} \quad \rho = 0.018$$

$$k := \sqrt{(\rho \cdot n)^2 + 2 \rho \cdot n} - \rho \cdot n \quad k = 0.381$$

$$j := 1 - \frac{k}{3} \quad j = 0.873$$

Moment due to concrete limits

$$M_{sc} := \frac{1}{2} \cdot f_c \cdot b \cdot k \cdot d \cdot \left(d - \frac{k \cdot d}{3} \right) \quad M_{sc} = 229 \text{ ft} \cdot \text{kip}$$

Moment due to steel limit

$$M_{ss} := A_s \cdot f_s \cdot j \cdot d \quad M_{ss} = 286 \text{ ft} \cdot \text{kip}$$

The maximum service moment is the minimum of the two values.

$$M_s := \min(M_{ss}, M_{sc}) \quad M_s = 229 \text{ ft} \cdot \text{kip}$$

(b) Determine if the beam will show cracking before reaching the service load

$$I_g := \frac{b \cdot h^3}{12} \quad I_g = 13333 \cdot \text{in}^4$$

$$M_{cr1} := \frac{f_r \cdot I_g}{\frac{h}{2}} \quad M_{cr1} = 64.5 \cdot \text{ft} \cdot \text{kip}$$

This is less than the service load so the section cracks. To demonstrate that the transformed section does not affect this conclusion, the following checks the cracked transformed section.

$$\Delta y := \frac{n \cdot A_s \cdot \left(d - \frac{h}{2} \right)}{n \cdot A_s + b \cdot h} \quad \Delta y = 0.697 \cdot \text{in}$$

$$I_{ut} := I_g + b \cdot d \cdot \Delta y^2 + n \cdot A_s \cdot \left(d - \frac{h}{2} - \Delta y \right)^2 \quad I_{ut} = 15400 \cdot \text{in}^4$$

$$M_{cr2} := \frac{f_r \cdot I_{ut}}{\frac{h}{2} - \Delta y} \quad M_{cr2} = 80.1 \cdot \text{ft} \cdot \text{kip} \quad \frac{M_{cr2}}{M_{cr1}} = 1.242$$

(c) Determine the nominal moment capacity of the section.

$$a := \frac{A_s \cdot f_y}{0.85 f_c \cdot b} \quad a = 3.67 \cdot \text{in}$$

$$M_n := A_s \cdot f_y \cdot \left(d - \frac{a}{2} \right) \quad M_n = 489 \cdot \text{ft} \cdot \text{kip}$$

(d) Compute the ratio of the nominal capacity of the beam to the maximum service level capacity and compare your findings to the ACI load factors and strength reduction factor.

$$\text{Ratio} := \frac{M_n}{M_s} \quad \text{Ratio} = 2.13$$

First, the extra computation of the uncracked transformed area gives only a 18% increase in the cracking moment. Comparing the cracking moment to the service moment shows that the service moment is almost 3 times the cracking moment. Therefore, unless the service moment is very close to the service moment, you can be assured that the section will crack based on the gross section calculation.

Second, the margin of safety between the service moment and the nominal capacity is 2.11. This is greater than the ultimate load factors and phi factors from ASCE-7 and ACI ($1.8/0.9 = 2.00$ if the entire load is classified as live load) indicating that a service level design is more conservative than LRFD design.

3.2 $w_d = 500 \text{ plf}$
 $w_L = 1200 \text{ plf}$
 $L = 22'$

$f'_c = 3000 \text{ psi}$
 $f_y = 60,000 \text{ psi}$
 $\rho = 0.6 \rho_{max}$

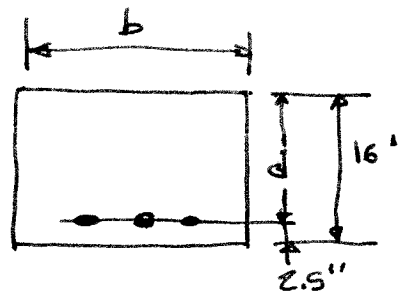

Assume $w_o = w_d = 500 \text{ plf}$
 and check assumption at conclusion of
 the design

$$w_u = 1.2(500 + 500) + 1.6(1200) = 3120 \text{ plf}$$

$$M_u = \frac{wL^2}{8} = \frac{3.12(22)^2}{8} = 189 \text{ ft-kip}$$

$$\rho_{max} = 0.85 \beta_1 \frac{f'_c}{f_y} \left(\frac{\epsilon_u}{\epsilon_u + 0.004} \right) = 0.85(0.85) \frac{3}{60} \left(\frac{0.003}{0.003 + 0.004} \right)$$

$$= 0.0155 \quad (\text{or from Table A.4})$$

$$\rho = 0.6 \rho_{max} = 0.6(0.0155) = 0.0093$$

$$R = \rho f_y \left(1 - 0.588 \frac{\rho f_y}{f'_c} \right) = 0.0093(60000) \left(1 - 0.588 \frac{0.0093(60)}{3} \right)$$

$$R = 497 \quad (\text{or by interpolation from Table A.5b})$$

Since $\rho = 0.6 \rho_b$ assume $\phi = 0.9$ (Confirmed by Table A.4)

$$bd^2 = \frac{M_u}{\phi R} = \frac{189(12000)}{0.9(497)} = 5070$$

$$d = h - 2.5 = 16 - 2.5 = 13.5$$

Solve for b

$$b = \frac{5070}{13.5^2} = 27.8$$

Use $b = 28 \text{ in}$

Check weight assumption $w_o = \frac{16 \times 28}{144}(150) = 467 \text{ plf}$
 which is less than assumed.

$$A_s = \rho bd = 0.0093(27.8)(13.5) = 3.49 \text{ in}^2$$

$$3 \#10 (\#36) = 3.81 \text{ in}^2$$

3.3

$$L = 20'$$

$$w_s = 2450 \text{ plf}$$

$$w_o = \frac{12 \times 25}{144} (150) = 313 \text{ plf}$$

$$M_s = \frac{wL^2}{8} = \frac{(2450 + 313)(20)^2}{8} \frac{1}{1000}$$

$$= 138 \text{ ft kip}$$

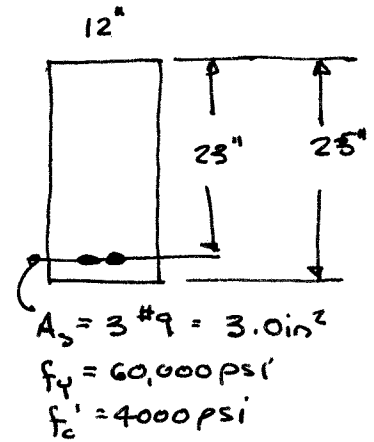

a)

$$a = \frac{A_s f_y}{0.85 f_c' b} = \frac{3.0 (60)}{0.85 (4) (12)} = 4.41 \text{ in}$$

$$M_u = A_s f_y (d - a/2) = 3.0 (60) (23 - \frac{4.41}{2}) \frac{1}{12} = 311 \text{ ft kips}$$

$$FS = \frac{M_u}{M_s} = \frac{311}{138} = 2.26$$

This exceeds the target value of 1.85

b)

$$n = 8 \quad \text{from } E_c = 57,000 \sqrt{f_c'} = 3,600,000$$

$$\rho = \frac{A_s}{bd} = \frac{3}{12 \times 23} = 0.0109$$

From Table A.6 $k = 0.339$, $j = 0.887$ by interpolation

$$\text{or } k = \sqrt{(2 \times 0.0109)^2 + 2.9 \times 0.0109} - 2(0.0109) = 0.339$$

$$f_s = \frac{M_s}{A_s j d} = \frac{138 (12000)}{3 (.887) 23} = 27,600 \text{ psi}$$

$$f_c = \frac{M_s}{k j b d^2} = \frac{138 (12000)}{.339 (.887) 12 (23)^2} = 868 \text{ psi}$$

$$c) \quad f_r = 7.5 \sqrt{f_c'} = 7.5 \sqrt{4000} = 474 \text{ psi}$$

$$I_g = \frac{bh^3}{12} = \frac{12 (25)^3}{12} = 15,625 \text{ in}^4$$

$$M_{cr} = \frac{f_r I}{Y} = \frac{474 (15,625)}{25/2} \frac{1}{12000} = 49.4 \text{ ft k}$$

$M_{cr} \ll M_s \quad \therefore$ Beam will crack

Problem 3.4 A rectangular reinforced concrete section has dimension $b=14$ in., $d=25$ in, and $h = 28$ in., and is reinforced with 3 No. 10 (No. 32) bars. The material strengths are $f'_c = 5000$ psi, $f_y = 60,000$ psi.

- (a) Find the moment that will produce first cracking at the bottom surface of the section basing your calculations on I_g , the moment of inertial of the gross section.
- (b) Repeat the calculation using I_{ut} the uncracked transformed moment of inertia.
- (c) Determine the maximum moment that can be carried without the concrete stress exceeding $0.45 f'_c$ or the steel stress exceeding $0.60 f_y$.
- (d) Determine the nominal moment capacity of the section.
- (e) Compute the ratio of nominal moment capacity from part (d) to the service level moment from part (c)
- (f) Comment on your results with particular attention to comparing parts (a) and (b) and comparing part (e) to established load factors.

▣ Reinforcement sizes

Given data

$$\begin{aligned}
 A_s &:= 3 \cdot A_{s10} & A_s &= 3.81 \text{ in}^2 & E_s &:= 29000000 \text{ psi} \\
 b &:= 14 \text{ in} & d &:= 25 \text{ in} & h &:= 28 \text{ in} \\
 f'_c &:= 5000 \text{ psi} & f_y &:= 60000 \text{ psi} & E_c &:= 57000 \sqrt{f'_c} \text{ psi} & E_c &= 4031 \text{ ksi} \\
 f_r &:= 7.5 \sqrt{f'_c} \text{ psi} & f_r &= 530 \text{ psi} & n &:= \frac{E_s}{E_c} & n &= 7.2
 \end{aligned}$$

- (a) Find the moment that will produce first cracking at the bottom surface of the section basing your calculations on I_g , the moment of inertial of the gross section.

$$I_g := \frac{b \cdot h^3}{12} \quad I_g = 25611 \text{ in}^4 \quad M_{cr1} := \frac{f_r \cdot I_g}{\frac{h}{2}} \quad M_{cr1} = 80.8 \text{ ft} \cdot \text{kip}$$

- (b) Repeat the calculation using I_{ut} the uncracked transformed moment of inertia.

$$\begin{aligned}
 \Delta y &:= \frac{n \cdot A_s \cdot \left(d - \frac{h}{2}\right)}{n \cdot A_s + b \cdot h} & \Delta y &= 0.719 \text{ in} \\
 I_{ut} &:= I_g + b \cdot d \cdot \Delta y^2 + n \cdot A_s \cdot \left(d - \frac{h}{2} - \Delta y\right)^2 & I_{ut} &= 28689 \text{ in}^4 \\
 M_{cr2} &:= \frac{f_r \cdot I_{ut}}{\frac{h}{2} - \Delta y} & M_{cr2} &= 95.5 \text{ ft} \cdot \text{kip} & \frac{M_{cr2}}{M_{cr1}} &= 1.181
 \end{aligned}$$

- (c) Determine the maximum moment that can be carried without the concrete stress exceeding $0.45 f'_c$ or the steel stress exceeding $0.60 f_y$.

$$f_c := 0.45 f'_c \quad f_c = 2250 \text{ psi}$$

$$f_s := 0.60f_y \quad f_s = 36000 \text{ psi}$$

$$\rho := \frac{A_s}{b \cdot d} \quad \rho = 0.011 \quad k := \sqrt{(\rho \cdot n)^2 + 2\rho \cdot n - \rho \cdot n} \quad k = 0.325 \quad j := 1 - \frac{k}{3} \quad j = 0.892$$

Moment due to concrete limits

Moment due to steel limit

$$M_{SC} := \frac{1}{2} \cdot f_c \cdot b \cdot k \cdot d \cdot \left(d - \frac{k \cdot d}{3} \right) \quad M_{SC} = 238 \text{ ft} \cdot \text{kip} \quad M_{SS} := A_s \cdot f_s \cdot j \cdot d \quad M_{SS} = 255 \text{ ft} \cdot \text{kip}$$

The maximum service moment is the minimum of the two values.

$$M_s := \min(M_{SS}, M_{SC}) \quad M_s = 238 \text{ ft} \cdot \text{kip}$$

(d) Determine the nominal moment capacity of the section.

$$a := \frac{A_s \cdot f_y}{0.85f_c \cdot b} \quad a = 3.84 \text{ in} \quad M_n := A_s \cdot f_y \cdot \left(d - \frac{a}{2} \right) \quad M_n = 440 \text{ ft} \cdot \text{kip}$$

(e) Compute the ratio of nominal moment capacity from part (d) to the service level moment from part (c)

$$\text{Ratio} := \frac{M_n}{M_s} \quad \text{Ratio} = 1.85 \quad 0.9 \text{ Ratio} = 1.66$$

$$\text{Ratio1} := \frac{M_s}{M_{cr1}} \quad \text{Ratio1} = 2.942$$

(f) Comment on your results with particular attention to comparing parts (a) and (b) and comparing part (e) to established load factors.

First, the extra computation of the uncracked transformed area gives an 18% increase in the cracking moment. Comparing the cracking moment to the service moment, Ratio1, shows that the service moment is almost 3 times the cracking moment. Therefore, unless the service moment is very close to the service moment, you can be assured that the section will crack.

Second, the margin of safety between the service moment and the nominal capacity is 1.8, 1.6 if a ϕ factor is included. This is greater than the ultimate load factors from ASCE-7 indicating that a service level design is far more conservative than LRFD design.

$$3.5 \quad f_y = 60,000 \text{ psi} \quad f_c' = 5000 \text{ psi}$$

$$a) \quad A_s = 2 \#8 = 2(0.79) = 1.58 \text{ in}^2$$

$$a = \frac{1.58(60)}{.85(5)12} = 1.86 \text{ in}$$

$$M_n = A_s f_y \left(d - \frac{a}{2} \right) = 1.58(60) \left(20 - \frac{1.86}{2} \right) \frac{1}{12}$$

$$= 151 \text{ ft kips}$$

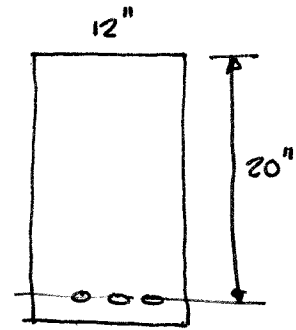

$$b) \quad A_s = 2 \#10 = 2(1.27) = 2.54 \text{ in}^2$$

$$a = \frac{A_s f_y}{.85 f_c' b} = \frac{2.54(60)}{.85(5)12} = 2.99 \text{ in}$$

$$M_n = 2.54(60) \left(20 - \frac{2.99}{2} \right) \frac{1}{12}$$

$$= 235 \text{ ft kips}$$

$$c) \quad A_s = 3 \#10 = 3(1.27) = 3.81 \text{ in}^2$$

$$a = \frac{3.81(60)}{.85(5)(12)} = 4.48 \text{ in}$$

$$M_n = 3.81(60) \left(20 - \frac{4.48}{2} \right) \frac{1}{12}$$

$$= 338 \text{ ft kips}$$

A check of net tensile strain shows $\epsilon_t = 0.0077$ so tensile steel has yielded.

Problem 3.6 A singly reinforced rectangular beam is to be designed, with an effective depth approximately 1.5 times the width, to carry a service load of 2000 lb/ft in addition to its own weight, on a 24 ft. simple span. The ACI Code factors are applied as usual. With $f_y = 60,000$ psi and $f'_c = 4000$ psi, determine the required concrete dimensions d , b , and h , and steel reinforcing bars for a) $\rho = 0.6 \rho_{max}$ and b) $\rho = \rho_{0.005}$. Include a sketch, to scale, of each cross section. Allow for No. 4 (No. 13) stirrups. Comment on your results.

Given properties

$$f_y := 60000 \text{ psi} \quad f'_c := 4000 \text{ psi} \quad l := 24 \text{ ft} \quad w_l := 2000 \cdot \frac{\text{lb}}{\text{ft}} \quad w_c := 150 \cdot \frac{\text{lb}}{\text{ft}^3}$$

Estimate beam dimensions for self weight determination

$$b := 12 \text{ in} \quad d := 18 \text{ in} \quad h := 21 \text{ in}$$

$$w_o := b \cdot h \cdot w_c$$

$$w_u := 1.2 \cdot w_o + 1.6 \cdot w_l \quad w_u = 3.515 \frac{\text{kip}}{\text{ft}}$$

$$M_u := w_u \cdot \frac{l^2}{8} \quad M_u = 253.1 \text{ kip} \cdot \text{ft}$$

$$\beta_1 := 0.85 - \frac{0.05(f'_c - 4000 \text{ psi})}{1000 \text{ psi}} = 0.85$$

$$\rho_{max} := 0.85 \cdot \beta_1 \cdot \frac{f'_c}{f_y} \cdot \frac{0.003}{0.003 + 0.004} = 0.0206$$

a) For $\rho = 0.6 \rho_{max}$, find the section properties to carry M_u .

$$\rho := 0.6 \rho_{max} \quad \rho = 0.0124 \quad \text{From table} \quad \text{Resistance} := \rho \cdot f_y \cdot \left(1 - 0.588 \cdot \frac{\rho \cdot f_y}{f'_c} \right)$$

$$\text{Resistance} = 662 \text{ psi} \quad \text{Since } \rho < \rho_{0.005}, \text{ then } \phi := 0.90$$

$$b := \sqrt[3]{\frac{M_u}{2.25 \cdot \phi \cdot \text{Resistance}}} = 13.134 \text{ in} \quad d := 1.5 \cdot b \quad d = 19.7 \text{ in}$$

$$A_s := \rho \cdot b \cdot d \quad A_s = 3.2 \text{ in}^2$$

A solution is to use 4-#8, $b = 14$ ", $d = 20.5$ ", and $h = 22$ ".

$$A_s := 4 \cdot 0.79 \text{ in}^2 \quad b := 14 \text{ in} \quad d := 20.5 \text{ in} \quad \text{giving a design capacity of}$$

$$a := \frac{A_s \cdot f_y}{0.85 \cdot f'_c \cdot b} = 3.98 \text{ in}$$

$$\phi M_n := \phi \cdot A_s \cdot f_y \cdot \left(d - \frac{a}{2} \right) \quad \phi M_n = 263 \text{ ft} \cdot \text{kip} \quad > M_u \quad M_u = 253.1 \text{ ft} \cdot \text{kip} \quad \text{OK}$$

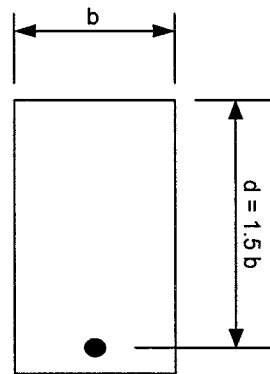

$$\begin{aligned}
 \text{b) } \rho_{005} &:= 0.85 \cdot \beta_1 \cdot \frac{f_c}{f_y} \cdot \frac{0.003}{0.003 + 0.005} \\
 \rho &:= \rho_{005} \quad \rho = 0.0181 \\
 \text{Resistance} &:= \rho \cdot f_y \cdot \left(1 - 0.588 \cdot \rho \cdot \frac{f_y}{f_c} \right) \quad \text{Resistance} = 911 \text{ psi} \\
 b &:= \sqrt[3]{\frac{M_u}{1.5^2 \cdot \phi \cdot \text{Resistance}}} = 11.8 \text{ in} \quad d := 1.5 \cdot b \quad d = 17.7 \text{ in} \\
 A_s &:= \rho \cdot b \cdot d \quad A_s = 3.78 \text{ in}^2
 \end{aligned}$$

This is satisfied by 4-#9 $A_s = 4.0 \text{ in}^2$. Beam dimensions would be $b = 12''$, $d = 18''$ and $h = 21''$ (or more when two layers of steel are used). The increase in depth accounts for the smaller area of steel.

Check:

$$\begin{aligned}
 b &:= 12 \text{ in} \quad d := 18 \text{ in} \quad A_s := 4 \cdot 1.0 \text{ in}^2 = 4.0 \text{ in}^2 \\
 a &:= \frac{A_s \cdot f_y}{0.85 \cdot f_c \cdot b} \quad a = 5.88 \text{ in} \\
 \phi M_n &:= \phi \cdot A_s \cdot f_y \cdot \left(d - \frac{a}{2} \right) \quad \phi M_n = 271.1 \text{ ft} \cdot \text{kip} > M_u \text{ OK}
 \end{aligned}$$

Comment: While there is a small savings in concrete using solution b, the final selection of reinforcement can often result in a reinforcement ratio greater than the code allows. In which case, the solution in a) is preferable.

- 3.7 A four span continuous beam of constant rectangular cross-section is supported at A, B, C, D, and E. The factored moments resulting from analysis are

At Supports, ft-kip	At midspan ft-kip
$M_a = 138$	$M_{ab} = 158$
$M_b = 220$	$M_{bc} = 138$
$M_c = 200$	$M_{cd} = 138$
$M_d = 220$	$M_{de} = 158$
$M_e = 138$	

Determine the required final concrete dimensions for this beam using $d=1.75 b$ and determine the reinforcement requirements at each critical moment section. Your final reinforcement ratio should not exceed $\rho = 0.6 \rho_{005}$, $f_y = 60,000$ psi and $f'_c = 6000$ psi

► Reinforcement Details

Given Properties

$$f'_c := 6000\text{psi} \quad f_y := 60000\text{psi} \quad \epsilon_u := 0.003$$

$$\beta_1 := 0.85 - 0.05 \cdot \frac{f'_c - 4000\text{psi}}{1000\text{psi}} = 0.75 \quad \phi := 0.90$$

Solution Approach:

Solve the first section using the Resistance Factors. Then, having selected a section, determine the reinforcement requirements for the remaining sections. Choose reinforcement bars to meet your criteria.

$$M_{n\text{reqd}} := \frac{220\text{ft}\cdot\text{kip}}{\phi} \quad M_{n\text{reqd}} = 244\text{ft}\cdot\text{kip}$$

$$\rho_{005} := \frac{0.85 \cdot \beta_1 f'_c}{f_y} \cdot \left(\frac{\epsilon_u}{\epsilon_u + 0.005} \right) = 0.024 \quad \rho := 0.6 \rho_{005} = 0.014$$

$$R := \rho \cdot f_y \cdot \left(1 - .588 \frac{\rho \cdot f_y}{f'_c} \right) \quad R = 788\text{psi}$$

$$b := \sqrt[3]{\frac{M_{n\text{reqd}}}{1.75^2 \cdot R}} = 10.7\text{in} \quad d := 1.75 \cdot b = 18.7\text{in}$$

$$A_s := b \cdot d \cdot \rho = 2.86\text{in}^2 \quad n := \frac{A_s}{A_{s8}} = 3.6$$

Try the following dimensions and then check the solution

$$b := 10\text{in} \quad h := 22\text{in} \quad d := h - 4\text{in} \quad \text{Additional cover is required because the bars have to be in two layers, See Table A.7 in text.}$$

$$A_s := 4 \cdot A_{s8} \quad A_s = 3.16\text{in}^2 \quad \text{Note: 3\#10 (No. 36) also works and allows the steel to be in one layer but require more steel.}$$

$$a := \frac{A_s \cdot f_y}{0.85 \cdot f_c \cdot b} = 3.72 \text{ in} \quad M_{n1} := A_s \cdot f_y \cdot \left(d - \frac{a}{2} \right) \quad M_{n1} = 255 \text{ ft} \cdot \text{kip} \quad \frac{M_{n1}}{M_{n\text{reqd}}} = 1.04 \quad \text{OK}$$

The next largest moment is 200 ft-kip. This is 10 percent less than the first interior joint so no adjustment of reinforcement is needed.

The largest positive moment is 158 ft-kip. This is 72 percent of the maximum moment so the steel requirements will be approximately:

$$A_{s2} := 0.72 A_s = 2.28 \text{ in}^2 \quad n_2 := \frac{A_{s2}}{A_{s8}} \quad n_2 = 2.88 \quad \text{use: } A_s := 3 A_{s8}$$

From Table A.7 use 3-#8 bars in one level

$$d_2 := h - 2.5 \text{ in} \quad a := \frac{A_s \cdot f_y}{0.85 f_c \cdot b} = 2.79 \text{ in} \quad M_{nab} := A_s \cdot f_y \cdot \left(d - \frac{a}{2} \right) = 197 \text{ ft} \cdot \text{kip}$$

Check total Capacity $\frac{\phi \cdot M_{nab}}{158 \text{ ft} \cdot \text{kip}} = 1.12 \quad \text{OK}$

Design end negative moment at A and E

$$A_{s2} := \frac{138}{158} \cdot A_s = 2.07 \text{ in}^2 \quad \text{Use 3\#8} \quad A_s := 3 A_{s8} = 2.37 \text{ in}^2$$

$$a := \frac{A_s \cdot f_y}{0.85 f_c \cdot b} = 2.79 \text{ in} \quad M_{n2} := A_s \cdot f_y \cdot \left(d - \frac{a}{2} \right) \quad M_{n2} = 197 \text{ ft} \cdot \text{kip}$$

Check total Capacity $\frac{\phi \cdot M_{n2}}{158 \text{ ft} \cdot \text{kip}} = 1.12 \quad \text{OK}$

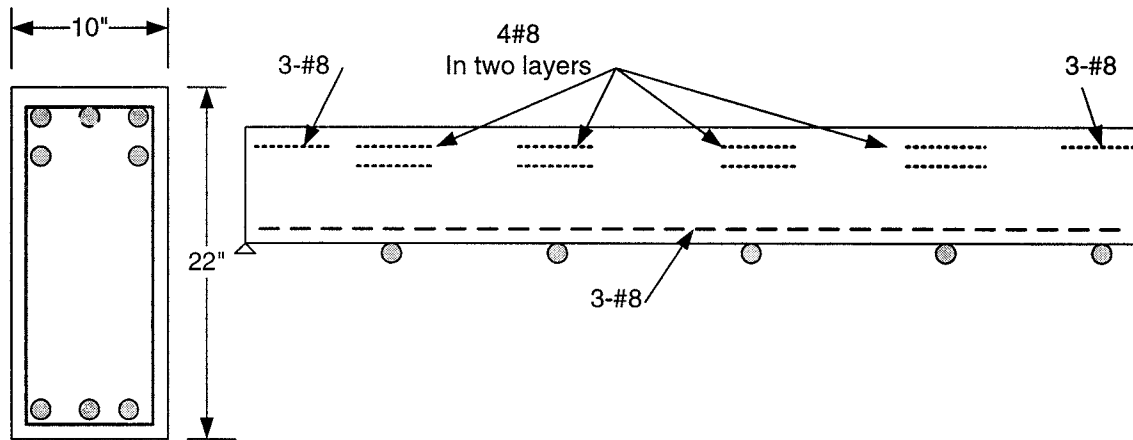

Problem 3.8 A two span continuous beam is supported on three concrete walls spaced 30 ft. on centers. A service live load of 1.5 kip/ft is to be carried in addition to the self weight of the beam and is to be applied in a pattern loading. The dimensions of the beam should be approximately $d=2b$, and the reinforcement is to be varied according to the demand. Determine concrete dimensions at all critical sections but select a constant section for the beam. Allow for No. 4 (No. 13) stirrups. Use a span to depth ratio of 15 for your first estimate of the depth. Adjust the depth if the reinforcement ratio is too high. Include sketches drawn to scale. Use $f'_c = 6000$ psi and $f_y = 60,000$ psi.

▣ Reinforcement Details

Given Properties

$$f'_c := 6000\text{psi} \quad f_y := 60000\text{psi} \quad \phi := 0.90 \quad \beta_1 := 0.85 - 0.05 \cdot \frac{f'_c - 4000\text{psi}}{1000\text{psi}} = 0.75$$

$$w_l := 1.5 \frac{\text{kip}}{\text{ft}} \quad L := 30\text{ft} \quad \gamma_c := 150\text{pcf}$$

Solution: Begin by estimating a beam depth and width, then compute the girder load.. Compute the maximum negative moment due to both spans being loaded then the maximum positive moment with only one span loaded with live load. Try:

$$h := \frac{L}{15} = 24\text{in} \quad d := h - 2.5\text{in} = 21.5\text{in} \quad b := \frac{h}{2} = 12.0\text{in}$$

$$w_g := \gamma_c \cdot b \cdot h = 0.30 \frac{\text{kip}}{\text{ft}} \quad w_u := 1.2w_g + 1.6w_l = 2.76 \frac{\text{kip}}{\text{ft}}$$

$$M_{\text{neg}} := \frac{w_u \cdot L^2}{8} = 310\text{ft} \cdot \text{kip}$$

By trial estimate a, then compute A_s for the negative moment over the support, select final A_s and check M_n

$$a := 4.0\text{in} \quad A_s := \frac{M_{\text{neg}}}{\phi \cdot f_y \cdot \left(d - \frac{a}{2}\right)} = 3.54\text{in}^2 \quad \text{Try 3-}\#10 \quad A_s := 3 \cdot A_{s10} = 3.81\text{in}^2$$

$$a := \frac{A_s \cdot f_y}{0.85 \cdot f'_c \cdot b} = 3.74\text{in} \quad M_n := A_s \cdot f_y \cdot \left(d - \frac{a}{2}\right) = 374\text{ft} \cdot \text{kip} \quad \phi \cdot M_n = 337\text{ft} \cdot \text{kip OK}$$

$$c := \frac{a}{\beta_1} = 4.98\text{in} \quad \frac{c}{d} = 0.232 < 3/8 \text{ therefore } \phi = 0.9 \text{ is OK}$$

By trial, compute the required A_s for the positive moment condition.

The maximum positive moment occurs with dead load on both spans and live load on one span only. The maximum moment for the DL occurs at $3/8L$ in from the end and the maximum moment for live load occurs $7/16L$ in from the end. Conservatively, take the sum of the two conditions and apply them at the same location.

$$M_{\text{pos}} := \frac{49 \cdot 1.6w_l \cdot L^2}{512} + \frac{9 \cdot 1.2w_g \cdot L^2}{128} = 229\text{ft} \cdot \text{kip}$$

$$a := 3.0 \text{ in} \quad A_s := \frac{M_{\text{pos}}}{\phi \cdot f_y \left(d - \frac{a}{2} \right)} = 2.55 \text{ in}^2 \quad \text{Try 3-}\#9 \quad A_s := 3 \cdot A_{s9} = 3.00 \text{ in}^2$$

$$a := \frac{A_s \cdot f_y}{0.85 \cdot f_c \cdot b} = 2.94 \text{ in} \quad M_n := A_s \cdot f_y \left(d - \frac{a}{2} \right) = 300 \text{ ft} \cdot \text{kip} \quad \phi \cdot M_n = 270 \text{ ft} \cdot \text{kip OK}$$

$$c := \frac{a}{\beta_1} = 3.92 \text{ in} \quad \frac{c}{d} = 0.182 < 3/8 \text{ therefore } \phi = 0.9 \text{ is OK}$$

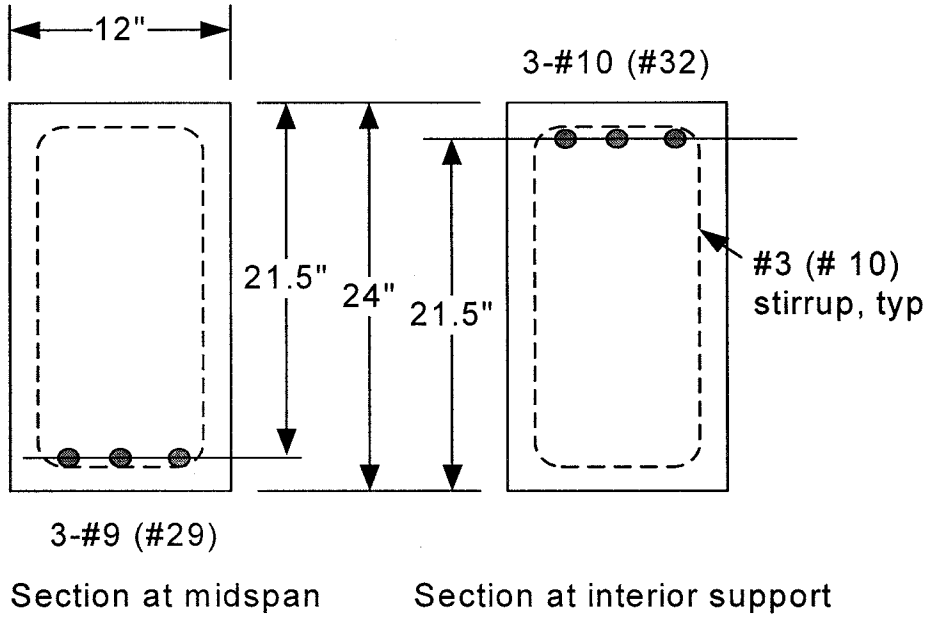

BACKGROUND FOR PROBLEM 3.8

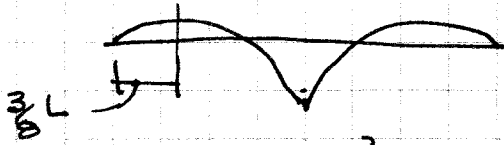
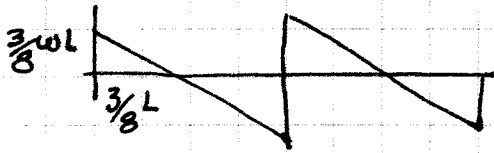
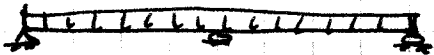

$$M_t = \frac{1}{2} \cdot \frac{3}{8} \cdot \frac{3}{8} wL^2$$

$$= \frac{9wL^2}{128}$$

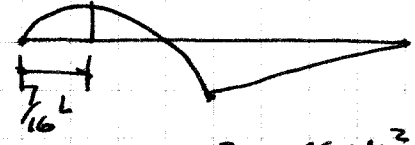
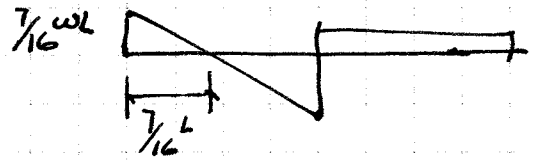
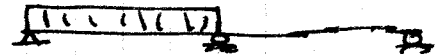

$$M_t = \frac{1}{2} \cdot \frac{7}{16} \cdot \frac{7}{16} wL^2 = \frac{49wL^2}{512}$$

Combined effect $w_D = \text{continuous}$, $w_L = \text{one span}$

$$\bar{x} = \frac{\left(\frac{3}{8}w_D L + \frac{7}{16}w_L L\right)L}{(w_D + w_L)L}$$

$$= \frac{\frac{3}{16}w_L + \frac{3}{8}w_D}{w_D + w_L} L$$

Both w_D and w_L are factored loads

$$M_t = \frac{1}{2} \left[\frac{7}{16}w_L + \frac{3}{8}w_D \right] L \bar{x}$$

3.9 $f_y = 60,000 \text{ psi}$, $f'_c = 4,000 \text{ psi}$

$$\rho_b = .85 \rho_1 \frac{f'_c}{f_y} \frac{E_u}{E_u + E_y}$$

$$= .85(.85) \frac{4}{60} \left(\frac{.003}{.003 + .00207} \right) = 0.0285$$

$$\bar{\rho}_{cy} = 0.85 \rho_1 \frac{f'_c d'}{f_y d} \frac{E_u}{E_u - E_y} + \rho'$$

$$= .85(.85) \frac{4}{60} \frac{2.5}{18} \frac{.003}{.003 - .00207} + \frac{1.58}{12 \times 18}$$

$$= 0.0289$$

$$\rho' = \frac{A_s'}{bd} = \frac{1.58}{12 \times 18} = 0.0073$$

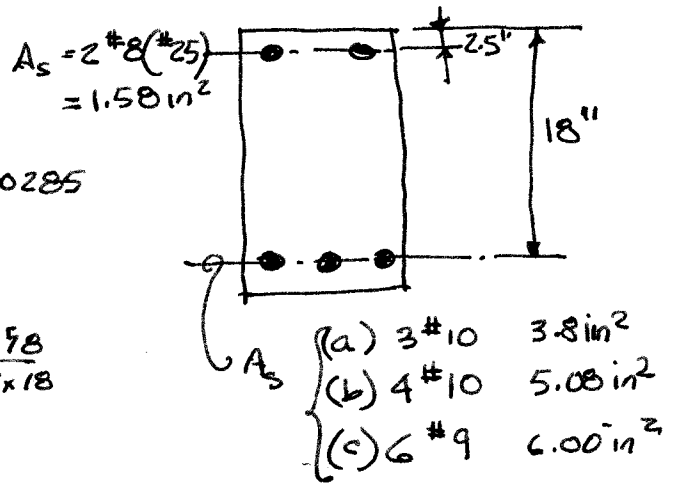

a) $A_s = 3.81 \text{ in}^2$ $\rho = \frac{3.81}{12 \times 18} = 0.0176$
 $\rho < \rho_b \therefore f_s = f_y$ $\rho < \bar{\rho}_{cy} \therefore f'_s < f_y$

by trial $f'_s = 41 \text{ ksi}$ $A_s = 3.81 - 1.58 \left(\frac{41}{60} \right) = 2.73 \text{ in}^2$

$$a = \frac{2.73(60)}{.85(4)12} = 4.01 \text{ in} \quad c = \frac{a}{\beta_1} = \frac{4.01}{.85} = 4.72$$

$$f'_s = E_s \frac{c - d'}{c} \epsilon_s = 29,000 \frac{4.72 - 2.5}{4.72} (0.003) = 41.4 \text{ ksi ok}$$

$$M_n = 1.58(41)(18 - 2.5) + 2.73(60) \left(18 - \frac{4.01}{2} \right) = 3624 \text{ in-kip} = 302 \text{ ft-kip}$$

b) $A_s = 5.08 \text{ in}^2$ $\rho = \frac{5.08}{12 \times 18} = 0.0235$

$\rho < \rho_b \therefore f_s = f_y$, $\rho < \bar{\rho}_{cy} \therefore f'_s < f_y$

by trial $f'_s = 52 \text{ ksi}$ $A_s = 5.08 - \frac{52}{60} 1.58 = 3.71 \text{ in}^2$

$$a = \frac{3.71(60)}{.85(4)12} = 5.46 \text{ in} \quad c = \frac{5.46}{.85} = 6.42$$

$$f'_s = 29,000 \frac{6.42 - 2.5}{6.42} (0.003) = 53.1 \text{ ksi ok use 53 ksi}$$

$$M_n = 1.58(53)(18 - 2.5) + 3.71(60) \left(18 - \frac{5.46}{2} \right) = 4697 \text{ in-kip} = 391 \text{ ft-kip}$$

c) $A_s = 6.0 \text{ in}^2$ $\rho = \frac{6.0}{12 \times 18} = 0.0278$

$\rho < \rho_b$ $f_s = f_y$ $\rho < \bar{\rho}_{cy}$ $f'_s < f_y$ but very close

Assume $f'_s = f_y$

$$a = \frac{(6.0 - 1.58)60}{.85(4)12} = 6.50 \text{ in} \quad c = \frac{6.50}{.85} = 7.65 \text{ in}$$

$$M_n = 1.58(60)(18 - 2.5) + (6.0 - 1.58)60 \left(18 - \frac{6.50}{2} \right) = 5381 \text{ in-kip} = 448 \text{ ft-kip}$$

Check $f'_s = 29,000 \frac{7.65 - 2.5}{7.65} (0.003) = 58.6 \text{ ksi} > f_y$ (cont.)

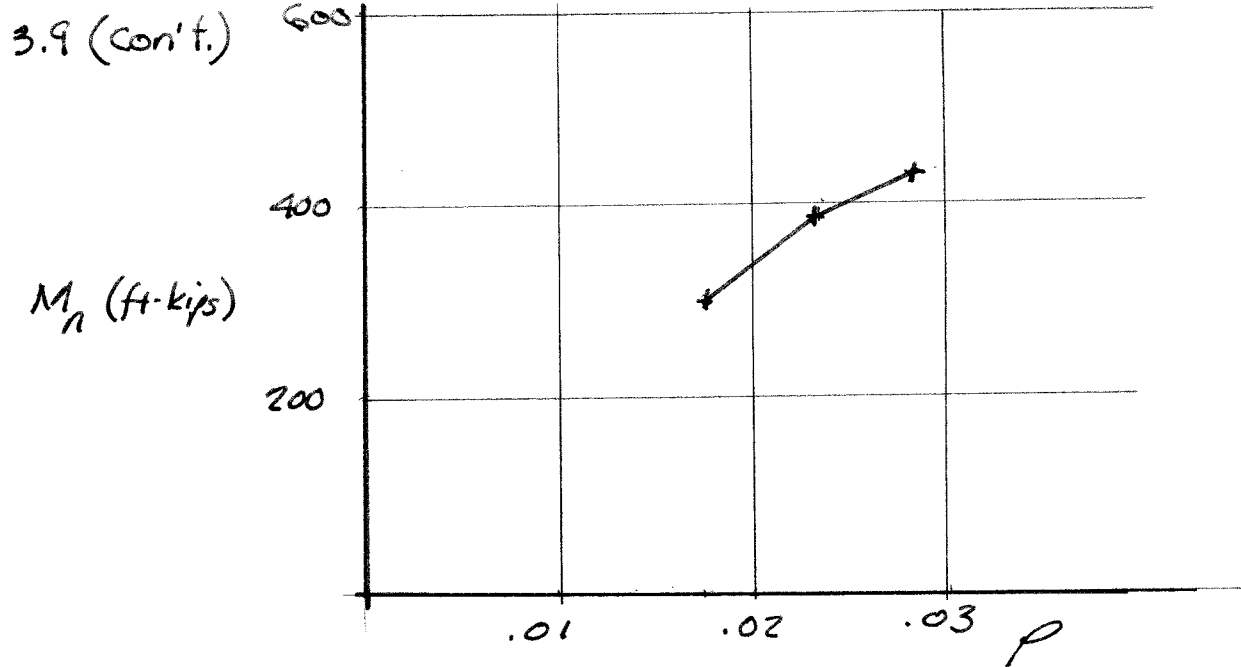

Note: for comparison purposes

Case		"exact"	Assume A_s' yields	ignore A_s'
a	M_n	302	305	290
	$\frac{M_n}{M_n \text{ "Exact"}}$	1.000	1.010	0.960
b	M_n	391	392	362
	$\frac{M_n}{M_n \text{ "Exact"}}$	1.000	1.003	0.926
c	M_n	448	448	408
	$\frac{M_n}{M_n \text{ "EXACT"}}$	1.000	1.000	0.911

3.10 $f'_c = 4000 \text{ psi}$, $f_y = 60,000 \text{ psi}$

$M_U = 400 \text{ ft-kips}$

First, try a singly reinforced beam with $\rho = \rho_{0.05} = 0.0181$ to assure $\phi = 0.9$

$A_s = \rho b d = 0.0181(24 \times 13) = 5.65 \text{ in}^2$

$a = \frac{A_s f_y}{0.85 f'_c b} = \frac{5.65(60)}{0.85(4)24} = 4.15 \text{ in}$

$M_{n1} = A_s f_y (d - \frac{a}{2}) = 5.65(60)(13 - \frac{4.15}{2}) \frac{1}{12} = 309 \text{ ft-kips}$

$M_n < M_U$ \therefore must add compression reinforcement.

From table 3.2 we know $f'_s < f_y$ $c = \frac{a}{\beta} = \frac{4.14}{0.85} = 4.87 \text{ in}$

$f'_s = E_s \epsilon_u \frac{c - d'}{c} = 29,000(0.003) \frac{4.87 - 3}{4.87} = 33.4 \text{ ksi}$ USE 33 ksi

$M_{n2} = \frac{M_U - M_{n1}}{\phi} = \frac{400 - 309}{0.9} = 101.1 \text{ ft-kips}$

$A'_s = \frac{M_{n2}}{f'_s (d - d')} = \frac{101.1(12)}{33(13 - 3)} = 4.96$

TRY $4 \#10 (\#32) = 5.08 \text{ in}^2$

Positive reinforcement at $f_y = 60 \text{ ksi}$

$A_s = 5.64 \text{ in}^2 + 4.96 \left(\frac{33}{60}\right) = 8.37 \text{ in}^2$

TRY $7 \#10 (\#32) A_s = 8.89 \text{ in}^2$

Because $A_s > A_s$ for $\rho = 0.0181$, ϵ_t & ϕ need to be checked

by trial $f'_s = 35.5 \text{ ksi}$

$a = \frac{(8.89 - 5.08 \left(\frac{35.5}{60}\right))60}{0.85(4)24} = 4.33 \text{ in}$ $c = 4.33 / 0.85 = 5.09 \text{ in}$

Check $f'_s = 29,000(0.003) \frac{5.09 - 3}{5.09} = 35.7$ OK use 35.5 ksi

$M_n = 5.08(35.5)(13 - 3) + \left[8.89 - 5.08 \left(\frac{35.5}{60}\right)\right]60 \left(13 - \frac{4.33}{2}\right) = 5629 \text{ in-k} = 469 \text{ ft-k}$

$\epsilon_t = 0.003 \frac{d - c}{c} = 0.003 \frac{13 - 5.09}{5.09} = 0.00466$

$\phi = 0.9 - 0.25 \left[\frac{0.005 - 0.00466}{0.001} \right] = 0.81$

$\phi M_n = 0.81(469) = 382 \text{ ft-kips} < M_U$

Revise design by increasing the compression reinforcement

try $4 \#11 (\#36) A'_s = 6.24 \text{ in}^2$

increasing positive reinforcement lowers ϕ (con't.)

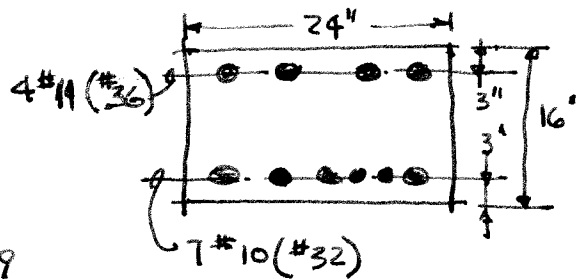

3.10 (cont.)

by trial $f'_s = 32.5 \text{ ksi}$ (see 3.11 for trial convergence)

$$a = \frac{[8.89 - 6.24(\frac{32.5}{60})]60}{.85(4)24} = 4.05 \text{ in} \quad c = \frac{4.05}{.85} = 4.77 \text{ in}$$

$$\text{check } f'_s = 29,000(.003) \frac{4.77-3}{4.77} = 32.3 \quad \text{ok use } 32.5 \text{ ksi}$$

$$M_n = 6.24(32.5)(13-3) + (8.89-6.24\frac{32.5}{60})60(13-\frac{4.05}{2})$$
$$= 5656 \text{ in-kips} = 471 \text{ ft-kips}$$

$$\text{Check } \epsilon_t \quad \epsilon_t = .003 \frac{d-c}{c} = .003 \left(\frac{13-4.77}{4.77} \right) = 0.00518$$
$$\epsilon_t > .005 \quad \phi = 0.9$$

$$\phi M_n = 471(0.9) = 424 \text{ ft-kips} > M_u \quad \text{OK}$$

Use 4 #11 (#36) compression
7 #10 (#32) Tension

Problem 3.11 For the beam with a triangular cross section shown in Figure P3.11, determine a) the balanced reinforcement ratio and b) the maximum reinforcement ratio if $\epsilon_t = 0.005$. The dimensions of the triangle are such that the width of the triangle equals the distance from the apex. The width at the effective width b equals the effective depth d . Draw the strain distribution, stress distribution, and define your notation.

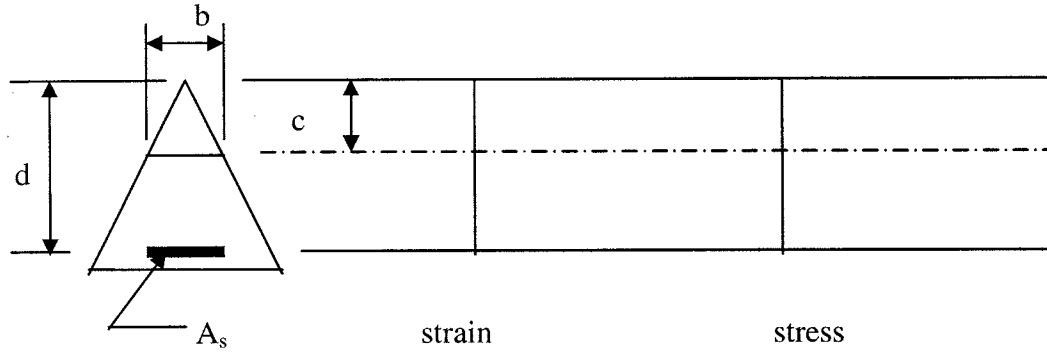

SOLUTION

a) Find the balanced reinforcement ratio

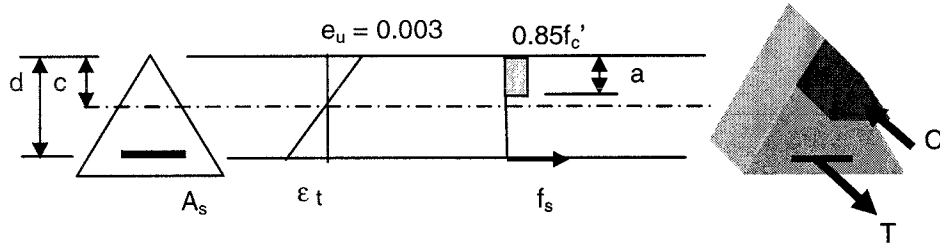

From Equilibrium

$$C = T$$

$$0.85f'_c (1/2 a b_a) = A_s f_y$$

Substitution $A_s = \rho b d$, where $b = d$ and $b_a = a$ gives

$$0.85f'_c a^2/2 = \rho d^2 f_y$$

Solve for ρ

$$\rho = \frac{0.85 f'_c}{2 f_y} \left(\frac{a}{d}\right)^2$$

The relationship between a and c is $a = \beta_1 c$. From the relationship of plane sections remain plane, the correlation of c/d is

$$\frac{c}{d} = \frac{\epsilon_u}{\epsilon_u + \epsilon_t}$$

Substitution for a and then c/d gives

$$\rho = \frac{0.85}{2} \frac{f'_c}{f_y} \beta_1^2 \left(\frac{\epsilon_u}{\epsilon_u + \epsilon_t} \right)^2$$

For the balanced condition, $\epsilon_t = \epsilon_y$ and ρ_b is

$$\rho_b = \frac{0.85}{2} \frac{f'_c}{f_y} \beta_1^2 \left(\frac{\epsilon_u}{\epsilon_u + \epsilon_y} \right)^2$$

Using grade 60 steel, so ϵ_y is 0.002 and $\epsilon_u = 0.003$, the balanced ratio becomes.

$$\rho_b = 0.153 \beta_1^2 \frac{f'_c}{f_y} \quad \leftarrow \text{Solution for balanced ratio}$$

b) Find the reinforcement ratio for $\epsilon_t = 0.005$.

For $\epsilon_t = 0.005$ and $\epsilon_u = 0.003$ the reinforcement ratio is

$$\rho_{0.005} = 0.060 \beta_1^2 \frac{f'_c}{f_y} \quad \leftarrow \text{Solution for reinforcement ratio when } \epsilon_t = 0.005$$

Problem 3.12 Develop a design table and chart for the moment capacity of rectangular concrete beams based on the use of the flexural resistance factor R (See table A.5a and Graph A.1a for examples). Material strengths are $f_y = 60,000$ psi, and $f_c' = 8000$ psi. The table and graph should begin with ρ_{min} and end at ρ_{max} . You must show how the maximum and minimum values for ρ were computed. You may use Excel or MathCAD to perform your calculations. Your submittal must include a table, a graph, and commentary on how you checked the work.

▢ Reinforcement Details

Given Properties

$$f_c' := 8000\text{psi} \quad f_y := 60000\text{psi} \quad \phi := 0.90 \quad \beta_1 := 0.85 - 0.05 \cdot \frac{f_c' - 4000\text{psi}}{1000\text{psi}} = 0.65$$

$$\rho_{min} := \max\left(\frac{200\text{psi}}{f_y}, \frac{3\sqrt{f_c' \cdot \text{psi}}}{f_y}\right) = 0.0045$$

$$\rho_{max} := 0.85\beta_1 \cdot \frac{f_c'}{f_y} \cdot \left(\frac{0.003}{0.003 + 0.005}\right) = 0.028$$

$$\rho := \rho_{min}..0.005.. \rho_{max}$$

$$R(\rho) := \rho \cdot f_y \cdot \left(1 - 0.588\rho \cdot \frac{f_y}{f_c'}\right)$$

$\rho =$	$R(\rho) =$
0.004	263
0.005	293
0.006	324
0.006	354
0.007	384
0.007	413
0.008	443
0.008	472
0.009	502
0.009	531
0.010	560
0.010	589
0.011	617
0.011	646
0.012	675
...	...

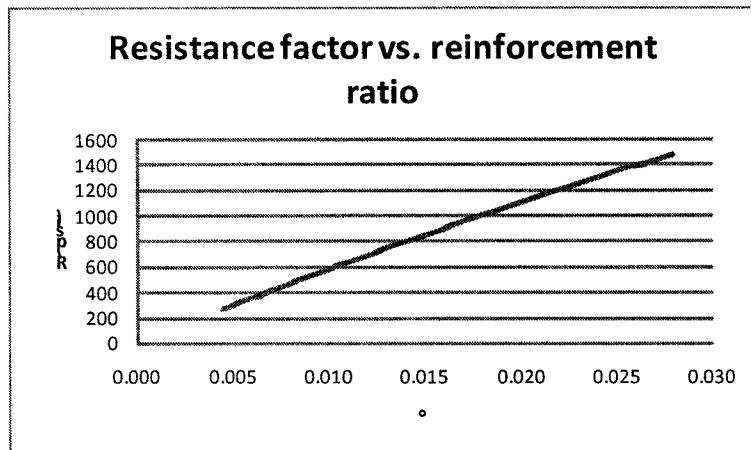

3.12 Excel solution

ρ	R (psi)
0.005	265
0.005	293
0.006	322
0.006	350
0.007	379
0.007	407
0.008	435
0.008	463
0.009	491
0.009	519
0.010	546
0.010	574
0.011	601
0.011	628
0.012	655
0.012	682
0.013	709
0.013	735
0.014	762
0.014	788
0.015	814
0.015	840
0.016	866
0.016	892
0.017	918
0.017	944
0.018	969
0.018	994
0.019	1019
0.019	1044
0.020	1069
0.020	1094
0.021	1119
0.021	1143
0.022	1168
0.022	1192
0.023	1216
0.023	1240
0.024	1264
0.024	1288
0.025	1311
0.025	1335
0.026	1358
0.026	1381
0.027	1404
0.027	1427
0.028	1450
0.028	1473

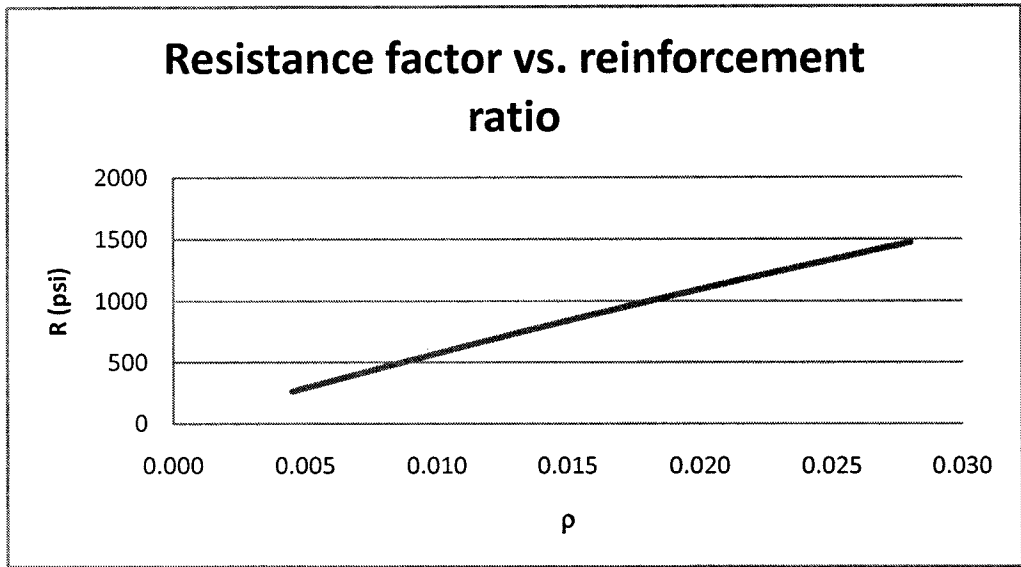

3.13 A rectangular beam made using concrete with $f'_c = 5000$ psi and steel with $f_y = 60,000$ psi has a width of $b = 18$ in., an effective depth of $d = 21$ in., and a total depth of $h = 24$ in. The beam is reinforced with 4 - No. 9 (No. 29) bars. Compute the nominal moment capacity assuming a) an equivalent rectangular stress block, b) a triangular stress block with a peak value of f'_c and c) a parabolic stress block with a peak value of f'_c (see Fig. P3.13). Compare and comment on your results knowing that the rectangular stress block correlates within 4% of test results.

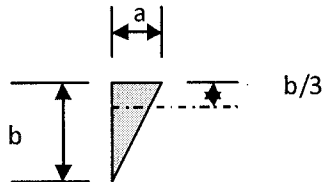

$$A = \frac{1}{2} ab$$

Triangle Properties

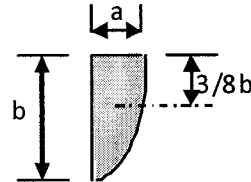

$$A = \frac{2}{3} ab$$

Parabola properties

Reinforcement Details

Given Properties

$$f'_c := 5000\text{psi} \quad f_y := 60000\text{psi} \quad \beta_1 := 0.85 - 0.05 \cdot \frac{f'_c - 4000\text{psi}}{1000\text{psi}} = 0.80 \quad \phi := 0.90$$

$$b := 18\text{in} \quad d := 21\text{in} \quad A_s := 4A_{s9}$$

a) Use equivalent rectangular stress block

$$a := \frac{A_s \cdot f_y}{0.85 f'_c \cdot b} = 3.14 \text{ in} \quad M_{nr} := A_s \cdot f_y \cdot \left(d - \frac{a}{2} \right) = 389 \text{ ft} \cdot \text{kip}$$

b) Use a triangular stress block

$$a_t := \frac{A_s \cdot f_y}{f'_c \cdot \frac{b}{2}} = 5.33 \text{ in} \quad M_{nt} := A_s \cdot f_y \cdot \left(d - \frac{a_t}{3} \right) = 384 \text{ ft} \cdot \text{kip}$$

c) Use a parabolic stress block

$$a_p := \frac{A_s \cdot f_y}{\frac{2}{3} f'_c \cdot b} = 4.00 \text{ in} \quad M_{np} := A_s \cdot f_y \cdot \left(d - \frac{3}{8} \cdot a_p \right) = 390 \text{ ft} \cdot \text{kip}$$

d) Now look at the ratios

$$\frac{M_{nr}}{M_{nt}} = 1.01 \quad \frac{M_{nr}}{M_{np}} = 1.00$$

CONCLUSIONS

The selection of the shape of the compression block is not a critical parameter. All results are within the 4% margin of error associated with correlation to test results. The use of the rectangular stress block has been calibrated over a very large range of beams and columns and found to be adequate and a convenient method of computing flexural capacity.

$$3.14 \quad f'_c = 6000 \text{ psi}$$

$$f_y = 60,000 \text{ psi}$$

$$L = 30'$$

$$w_D = 0.475 \text{ kip/ft}$$

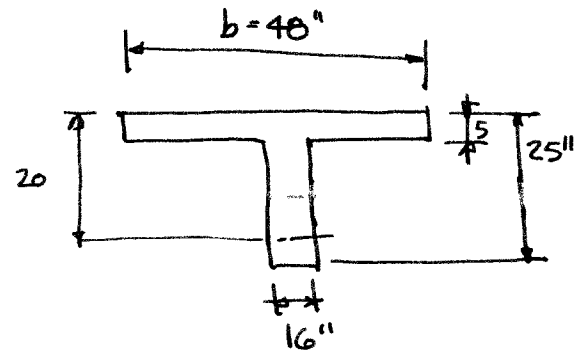

Effective width

$$b_{\text{eff}} = \left\{ \begin{array}{l} \frac{30}{4}(12) = 90'' \\ 48'' \\ 4b_w = 4(16) = 64'' \end{array} \right\} \text{ use } 48 \text{ in}$$

↑ isolated beam

$$w_D = \frac{150}{144} [16 \times 25 + 32 \times 5]$$

$$w_D = 583 \text{ pft}$$

$$\rho_{\text{max}} = 0.0273 \quad \text{TABLE A.4}$$

$$\rho = 0.5\rho_{\text{max}} = 0.0136$$

$$A_s = \rho b d = 0.0136 (48) 20 = 13.1 \text{ in}^2$$

$$\text{Use } \#11 (\#36) \quad A_s = 12.48 \text{ in}^2$$

$$a = \frac{A_s f_y}{0.85 f'_c b} = \frac{12.48 (60)}{0.85 (6) 48} = 3.06 \text{ in} < h_f \quad \text{ok with rect. section}$$

$$M_n = A_s f_y (d - a/2) = 12.48 (60) (20 - \frac{3.06}{2}) = 13,830 \text{ in kip}$$

$$M_n = 1153 \text{ ft kips}$$

$$c = \frac{a}{\beta_1} = \frac{3.06}{0.75} = 4.08 \quad \frac{c}{d} = \frac{4.08}{20} = 0.204 < 0.375 \quad \therefore \phi = 0.9$$

$$\text{Total capacity} = \phi M_n = 0.9 (1153) = 1038 \text{ ft-kips}$$

$$\text{Dead load } M_D = w_D \frac{L^2}{8} = 1.2 \frac{(0.475 + 0.583) 30^2}{8} = 143 \text{ ft-kips}$$

$$M_L = \phi M_n - M_D = 895 \text{ ft-kips}$$

$$1.6 w_L \frac{L^2}{8} = M_L \quad w_L = \frac{8 M_L}{1.6 L^2} = \frac{8 (895)}{1.6 (30)^2} = 4.97 \text{ kip/ft}$$

$$\text{Posted Load} = \frac{w_L}{b} = \frac{4.97}{4} = 1.24 \text{ ksi} = \underline{\underline{1240 \text{ psf}}}$$

Problem 3.15

A rectangular beam has a cross section 8 in. wide and an effective depth of 10 in. and a total depth of 12 in. is reinforced with a single fiberglass reinforcing bar that has a cross sectional area of 0.45 in.² The bar has a nominal tensile strength of 140,000 psi, a linear stress strain curve to failure, and a strain at failure of 1.8%, and a modulus of elasticity of 7,800,000 psi. The concrete strength is $f_c = 6000$ psi. Determine the nominal capacity of the section.

Given Data

$$\begin{aligned}
 b &:= 8\text{in} & h &:= 12\text{in} & d &:= 10\text{in} & f_c &:= 6000\text{psi} & f_u &:= 140\text{ksi} & E_g &:= 7800000\text{psi} \\
 \epsilon_u &:= 0.003 & \epsilon_{ug} &:= 0.018 \\
 \beta_1 &:= 0.75 & A_g &:= 0.45\text{in}^2
 \end{aligned}$$

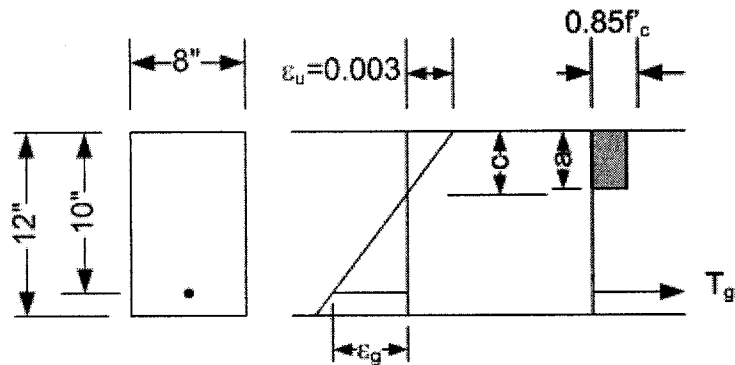

First Trial, assume that the fiberglass rod ruptures and the concrete fails in compression

$$\begin{aligned}
 T_n &:= f_u \cdot A_g & T_n &= 63.0 \text{ kip} \\
 a &:= \frac{T_n}{0.85f_c \cdot b} & a &= 1.544 \text{ in} & c &:= \frac{a}{\beta_1} & M_n &:= T_n \cdot \left(d - \frac{a}{2}\right) = 581.4 \text{ in}\cdot\text{kip} \\
 \epsilon_{g1} &:= \epsilon_u \cdot \frac{d - c}{c} & \epsilon_{g1} &= 0.012 & \frac{\epsilon_{g1}}{\epsilon_{ug}} &= 0.643
 \end{aligned}$$

The strain in the glass is only 33% of the ultimate strain, therefore we do not have compatibility on the section and the fiberglass rod does not fail. We need to set up compatibility conditions and then solve for equilibrium.

By trial assume $a := 1.268\text{in}$ and iterate until the $a_{\text{mod}} = a$. When they are equal, we have compatibility, e.g., the location of the neutral axis results in a strain and corresponding force in the reinforcement to balance the compression force.

$$\begin{aligned}
 c &:= \frac{a}{\beta_1} \\
 \epsilon_{g1} &:= \epsilon_u \cdot \frac{d - c}{c} & \epsilon_{g1} &= 0.015 \\
 T_g &:= E_g \cdot \epsilon_{g1} \cdot A_g
 \end{aligned}$$

$$a_{\text{mod}} := \frac{T_g}{0.85 \cdot f_c \cdot b} \quad a_{\text{mod}} = 1.268 \text{ in}$$

Compute the nominal moment capacity using the usual equation except that $A_s f_y$ is replaced by the tensile force T_g .

$$M_n := T_g \cdot \left(d - \frac{a}{2} \right) \quad M_n = 485 \text{ in-kip}$$

The stress in the fiberglass rod is

$$f_g := E_g \cdot \epsilon_{g1} \quad f_g = 115 \text{ ksi}$$

$$\frac{f_g}{f_u} = 0.821$$

COMMENT:

The beam fails in concrete compression with the fiberglass reinforcement at only 82% of its ultimate tensile capacity. Using the nominal tensile capacity of the glass without adjusting for the modulus of elasticity leads to over prediction for the beam capacity.

Problem 3.16 compute the maximum and minimum reinforcement ratios for reinforcement with 80 ksi yield point and $f'_c = 4000$ to 8000 psi in 1000 psi increments similar to those shown in table A.4a of Appendix A. Using the maximum and minimum reinforcement ratios, develop resistance factors and design graphs similar to Table A.5b and Graph A.1a

Solution: Assume maximum tensile strain in the steel is $\epsilon_t = 0.005$

$f_y =$	80000 psi				
series	1	2	3	4	5
$f'_c =$	4000	5000	6000	7000	8000 psi
β_1	0.85	0.80	0.75	0.70	0.65
$\rho_{min} =$	0.0025	0.0027	0.0029	0.0031	0.0034
$\rho_{max} =$	0.0159	0.0135	0.0123	0.0114	0.0107

ρ	R (psi)				
0.0010					
0.0015	118				
0.0020	156				
0.0025	194	195			
0.0030	232	233	234	234	
0.0035	268	271	272	272	272
0.0040	305	308	310	310	310
0.0045	341	345	347	347	347
0.0050	376	381	384	384	384
0.0055	412	417	421	421	421
0.0060	446	453	457	457	457
0.0065	480	488	494	494	494
0.0070	514	523	529	529	529
0.0075	547	558	565	565	565
0.0080	580	592	600	600	600
0.0085	612	626	635	635	635
0.0090	644	659	669	669	669
0.0095	675	692	703	703	703
0.0100	706	725	737	737	737
0.0105	736	757	771	771	771
0.0110	766	789	804	804	
0.0115	796	820	837		
0.0120	825	852	870		
0.0125	853	882			
0.0130	881	913			
0.0135	909	943			
0.0140	936				
0.0145	962				
0.0150	988				
0.0155	1014				
0.0160	1039				

Problem 3.16 (cont.)

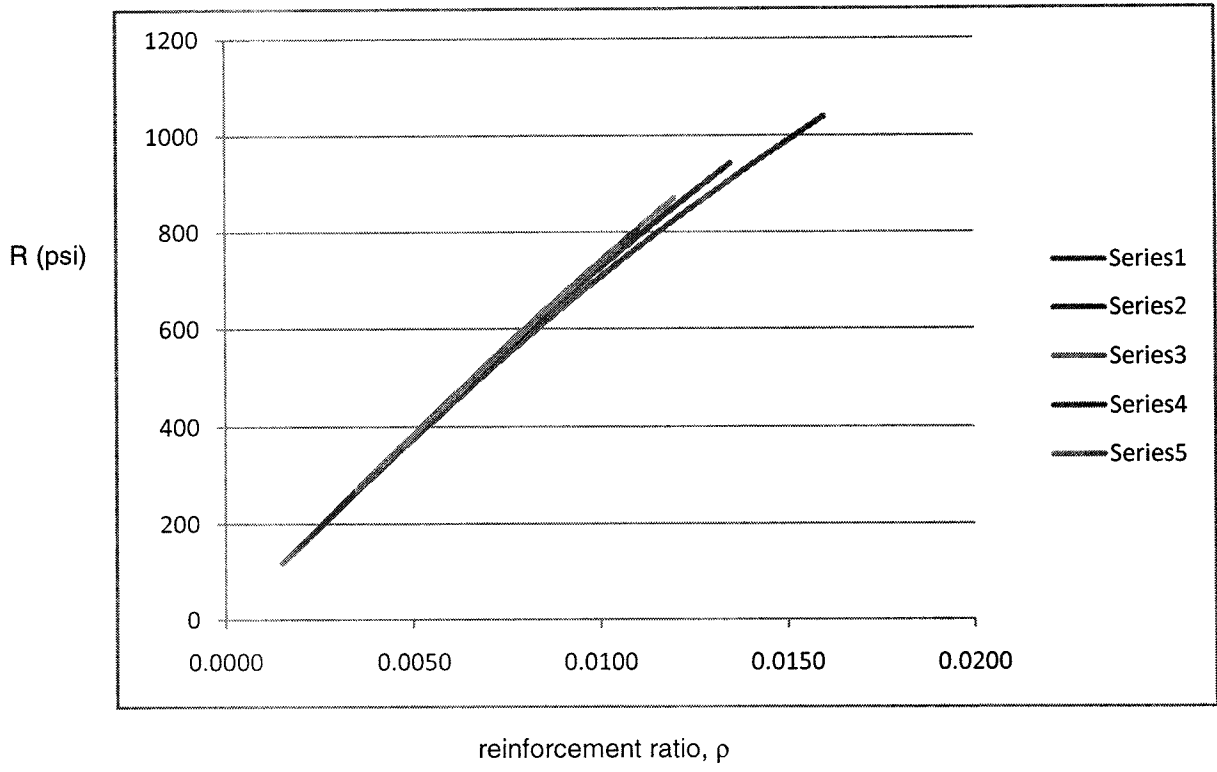

$$\frac{4.1}{V_u} = 60.0 \text{ kips} \quad f'_c = 5000 \text{ psi} \quad V_u = \phi V_n$$

(a) NO WEB STEEL: $V_u = \frac{1}{2} \phi V_c$

$$V_u = \frac{1}{2} (\phi z \sqrt{f'_c}) b w d$$

$$b w d = \frac{V_u}{\phi \sqrt{f'_c}} = \frac{60,000}{0.75 \sqrt{5000}} = 1131 \text{ in.}^2 \rightarrow \begin{cases} b = 23.8 \text{ in.} \\ d = 47.6 \text{ in.} \end{cases}$$

(b) MINIMUM WEB STEEL: $(A_s = 0.75 \sqrt{f'_c} \frac{b w s}{f_y} \geq 50 \frac{b w s}{f_y})$

$$V_u = \phi V_c = \phi z \sqrt{f'_c} b w d$$

$$b w d = \frac{60,000}{0.75 \times 2 \sqrt{5000}} = 566 \text{ in.}^2 \rightarrow \begin{cases} b = 16.8 \text{ in.} \\ d = 33.6 \text{ in.} \end{cases} *$$

(c) $V_s = 2 V_c$

$$V_u = \phi (V_s + V_c) = 3 \phi V_c = 3 \phi z \sqrt{f'_c} b w d$$

$$b w d = \frac{60,000}{6 \times 0.75 \sqrt{5000}} = 189 \text{ in.}^2 \rightarrow \begin{cases} b = 9.7 \text{ in.} \\ d = 19.4 \text{ in.} \end{cases}$$

* NOTE: THIS AREA COULD BE REDUCED IF V_s CONTRIBUTED BY $A_{s \text{ MIN}}$ IS ACCOUNTED FOR -

4.2 $\lambda = 1$

$$w_u = 1.2 \times 1.27 + 1.6 \times 3.70 = 7.44 \text{ Kips/ft}$$

$$V_u = 7.44 \times 15/2 = 55.8 \text{ Kips}$$

$$V_{u,d} = 55.8 \times 7.44 \times \frac{17.5}{12} = 45.0 \text{ Kips}$$

$$\phi V_c = 0.75 \times 2 \sqrt{4000} \times \frac{10 \times 17.5}{1000} = 16.6 \text{ Kips}$$

$$s@d = \frac{\phi A_v f_y t d}{V_u - \phi V_c} = \frac{0.75 \times 0.22 \times 60 \times 17.5}{45.0 - 16.6} = 6.10''$$

$$s \leq d/2 = \frac{17.5}{2} = 8.75''$$

$$s \leq 24''$$

$$s \leq \frac{A_v f_y t}{50 b_w} = \frac{0.22 \times 60,000}{50 \times 10} = 26.4''$$

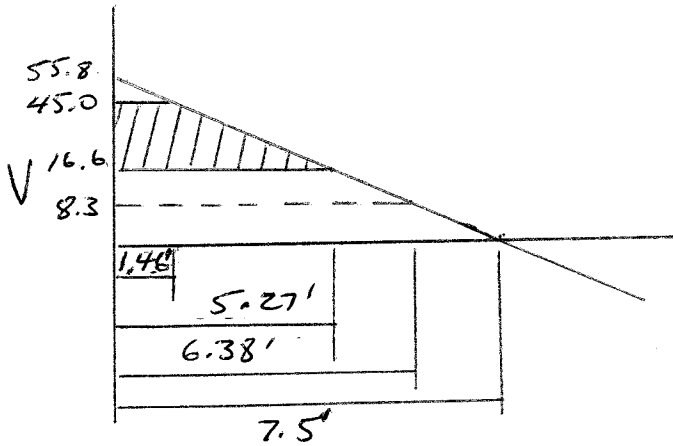
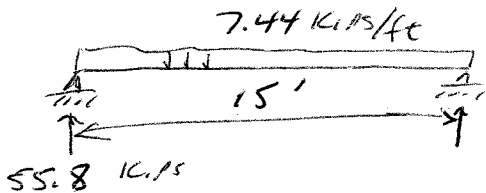

CRITICAL SECTION @d FROM
FACE OF SUPPORT

$$x = 1.46' \quad V = 45.0 \text{ Kips}$$

M.I.N. STIRRUPS REQUIRED

$$\text{TO } \frac{1}{2} \phi V_c$$

$$4.3 \quad \lambda = 1$$

$$V_c = \left(1.9 \sqrt{f_c} + 2500 \rho_w \frac{V_u d}{M_u} \right) b_w d \leq 3.5 \sqrt{f_c} b_w d$$

$$\text{AT } x = d; \quad V_u = 45.0 \text{ KIPS}$$
$$M_u = 55.8 \times 1.46 - 7.44 \times \frac{1.46^2}{2} = 73.5 \text{ I-K}$$

$$\frac{V_u d}{M_u} = \frac{45.0 \times 1.46}{73.5} = 0.89 < 1.0 \text{ OK}$$

$$\rho_w = \frac{3.00}{10 \times 17.5} = 0.0171$$

$$V_{c,d} = \left(1.9 \sqrt{4000} + 2500 \times 0.0171 \times 0.89 \right) \frac{10 \times 17.5}{1500}$$
$$= 27.7 \text{ KIPS}$$

$$\text{CHECK } 3.5 \sqrt{4000} \times \frac{10 \times 17.5}{1500} = 38.7 \text{ KIPS OK}$$

$$\phi V_c = 0.75 \times 27.7 = 20.8 \text{ KIPS}$$

$$\frac{1}{2} \phi V_c = 10.4 \text{ KIPS}$$

$$S_d = \frac{\phi A_s f_y d}{V_u - \phi V_c} = \frac{0.75 \times 0.22 \times 60 \times 17.5}{45.0 - 20.8} = 7.2''$$

THE ADDITIONAL DESIGN TIME REQUIRED BY THE MORE ACCURATE EQUATION WOULD NOT BE MADE UP IN CONSTRUCTION COST SAVINGS, EXCEPT IN SITUATIONS OF EXTREME CONGESTION -

4.4

$$\lambda = 1$$

$$w_u = 1.2 \times 2.67 + 1.6 \times 5.36 = 11.78 \text{ Kips/ft}$$

$$V_u = 11.78 \times 24/2 = 141.4 \text{ Kips}$$

$$V_{u@d} = 141.4 - 11.78 \times \frac{31}{12} = 111.0 \text{ Kips}$$

$$\phi V_c = 0.75 \times 2 \sqrt{5000} \times \frac{14 \times 31}{1000} = 46.0 \text{ Kips}$$

$$S@d = \frac{\phi A_s f_y t d}{V_u - \phi V_c} = \frac{0.75 \times 0.4 \times 60 \times 31}{111.0 - 46.0} = 8.6''$$

$$S \leq d/2 = 31/2 = 15.5''$$

$$S \leq 24''$$

$$S \leq \frac{A_s f_y t}{50 b_w} = \frac{0.4 \times 60,000}{50 \times 14} = 34.3''$$

$$S \leq \frac{A_s f_y t}{0.75 \sqrt{f_c} b_w} = \frac{0.4 \times 60,000}{0.75 \sqrt{5000} \times 14} = 32.3''$$

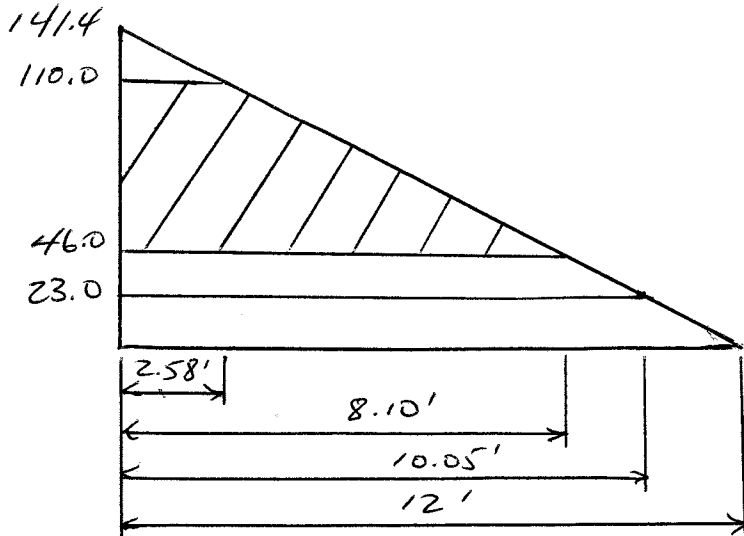
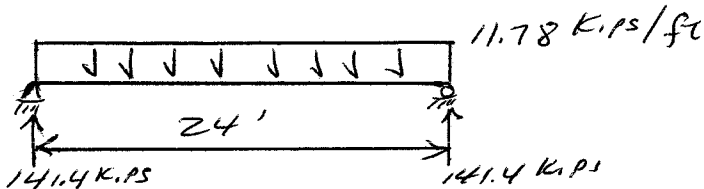

Critical section @ d
 from face of support.
 $x = 2.58'$, $V = 111.0 \text{ Kips}$
 minimum stirrups
 required to $\frac{1}{2} \phi V_c$

Use No. 4 (No. 13)
 stirrups

$$1 \text{ space @ } 4'' = 4''$$

$$7 \text{ spaces @ } 8'' = 54''$$

$$4 \text{ spaces @ } 15'' = 60''$$

$$\frac{118''}{12} = 9' - 10''$$

Total of 12 No. 4 (No. 13) stirrups for each half span.

4-4

4.5

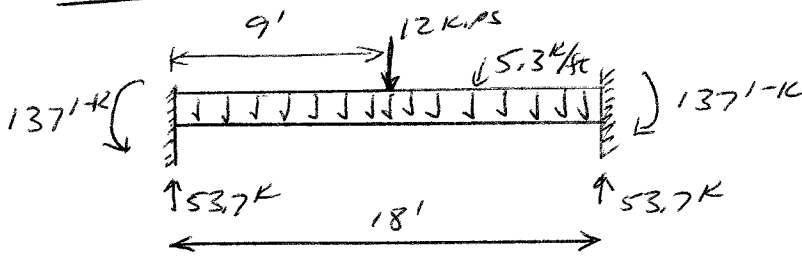

$$M_{u,d} = 53.7 \times 9 - \frac{1}{2} \times 5.3 \times 9^2 - 137 = 132 \text{ k-ft}$$

$$V_{u,d} = 53.7 - 5.3 \times 1.33 = 46.6 \text{ k}$$

$$M_{u,d} = 53.7 \times 1.33 - \frac{1}{2} \times 5.3 \times 1.33^2 - 137 = -70.3 \text{ k-ft}$$

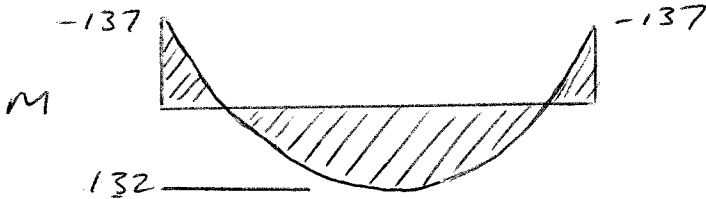

$$(a) V_c = 2\sqrt{f_c} b w d$$

$$= \frac{2\sqrt{4000} \times 11 \times 16}{1000} = 22.3 \text{ kips}$$

$$\phi V_c = 0.75 \times 22.3 = 16.7 \text{ kips}$$

$$\frac{1}{2} \phi V_c = 8.4 \text{ kips}$$

$$\frac{x}{53.7 - 16.7} = \frac{9}{53.7 - 6}$$

$$x = 6.98'$$

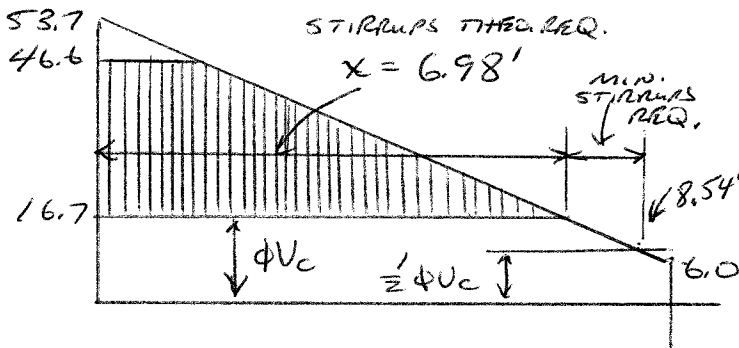

$$(b) V_c = (1.9\sqrt{f_c} + 2500 \rho_w \frac{V_{u,d}}{M_u}) b w d$$

$$V_{c,d} = (1.9\sqrt{4000} + 2500 \times 0.017 \frac{46.6 \times 1.33}{70.3}) \times 11 \times 16 / 1000 = 27.7 \text{ kips}$$

$$\phi V_c = 0.75 \times 27.7 = 20.8 \text{ kips}$$

$$\frac{1}{2} \phi V_c = 10.4 \text{ kips}$$

RECALCULATE ϕV_c AT REGULAR INTERVALS ALONG THE SPAN TO DETERMINE x .

COMMENT: THE MORE EXACT EQUATION ALLOWS A LITTLE GREATER PORTIONS OF THE BEAM TO BE UNREINFORCED FOR SHEAR - THE DIFFERENCE IS VERY SMALL -

4.6 $\phi V_c = \frac{0.75 \times 2 \sqrt{4000} \times 11 \times 16}{1000} = 16.7 \text{ KIPS}$

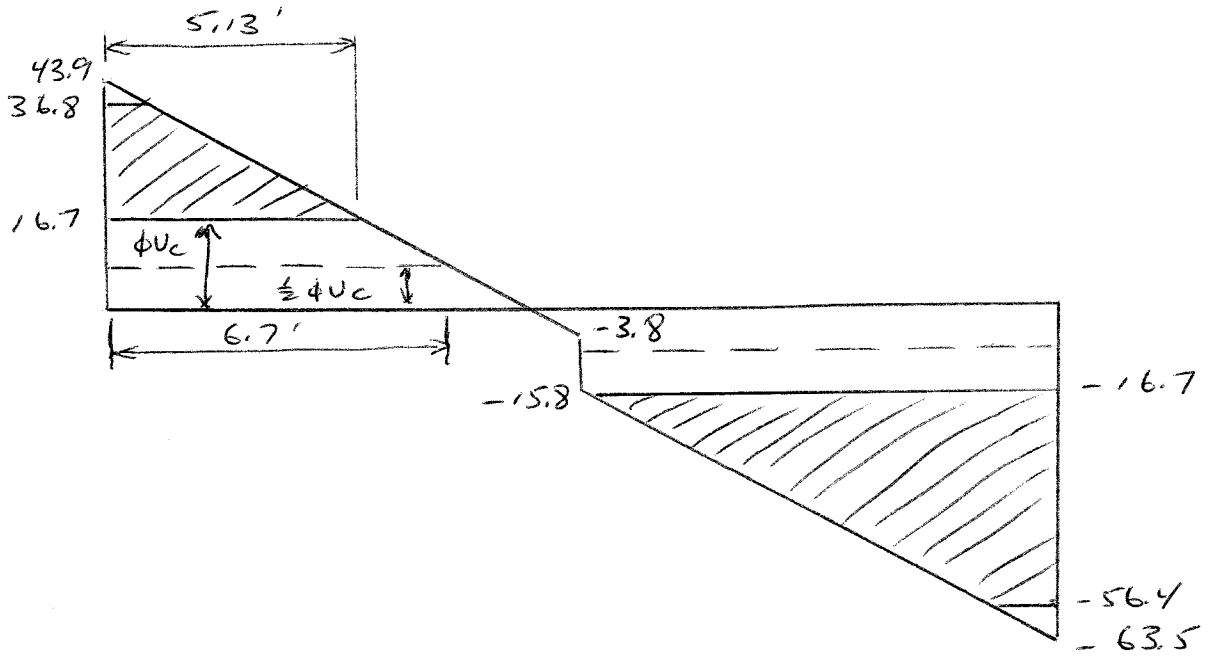

STIRRUPS ARE NOW REQUIRED OVER ENTIRE RIGHT HALF OF BEAM. THE REQUIREMENTS FOR THE LEFT HALF HAVE CHANGE ONLY A LITTLE, WITH SLIGHTLY LESS OF THE BEAM REQUIRING SHEAR REINFORCEMENT.

4.7

SHEAR PROBLEM 4.5 FOR SHEAR ENVELOPE -

MAXIMUM SHEAR TO BE TAKEN BY STIRRUPS

$$\phi V_s = V_u - \phi V_c = 46.6 - 16.7 = 29.9 \text{ KIPS}$$

$$\begin{aligned} \text{MAXIMUM SPACING ALLOWED, } S_{\text{MAX}} &\leq \frac{d}{2} = 8" \\ &\leq 24" \\ &\leq \frac{A_s f_{yt}}{50 b w} = 24" \end{aligned}$$

$$\begin{aligned} \text{MAXIMUM STIRRUP SPACING } S_d &= \frac{\phi A_s f_{yd}}{\phi V_s} \\ &= \frac{0.75 \times 0.22 \times 60 \times 16}{29.9} \\ &= 5.3" \end{aligned}$$

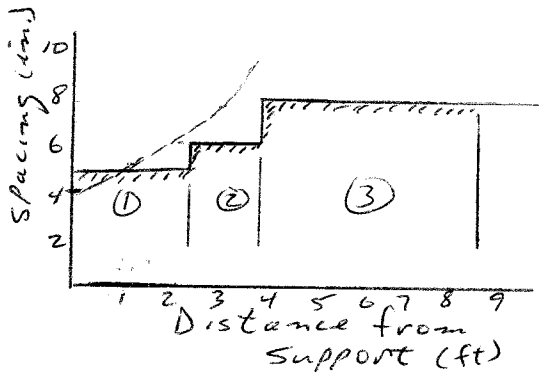
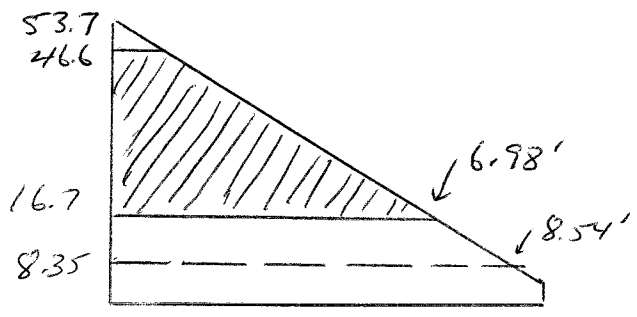

$$\begin{aligned} \textcircled{1} &= 2\frac{1}{2}" + 5 @ 5" = 27.5" \\ \textcircled{2} &= 3 @ 6" = 18" \\ \textcircled{3} &= 7 @ 8" = 56" \\ &\hline &= 101.5" \end{aligned}$$

COMMENT:
THE ACTUAL STIRRUP SPACING CAN BE SELECTED IN MANY WAYS. FOR EASE IN CONSTRUCTION, IT IS PRUDENT TO KEEP THE NUMBER OF DIFFERENT SPACINGS TO A MINIMUM

PLACE FIRST STIRRUP AT $\frac{1}{2}$ THE FIRST SPACING FROM THE FACE OF THE SUPPORT -

4.8 SEE PROBLEM 4.6 FOR SHEAR ENVELOPE.

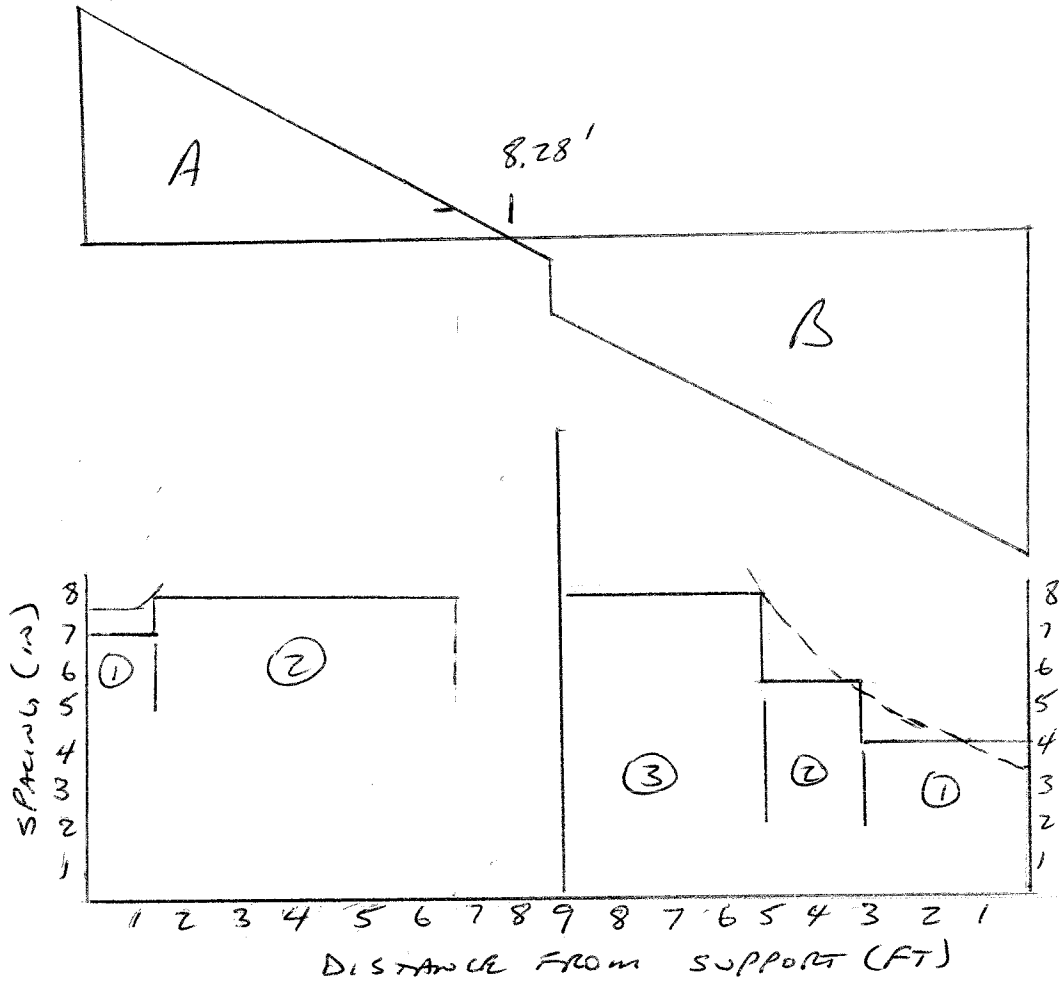

$$A: S_d = \frac{\phi A_s f_y d}{V_u - \phi V_c} = 7.84''$$

$$B: S_d = 4.0''$$

$$\frac{1}{2} \phi V_c = 8.35 @ x = 6.7' \\ \text{or } 80.4''$$

$$\frac{1}{2} \phi V_c @ x = 9' \text{ or } 108''$$

$$\textcircled{1} = 3'' + 2 @ 7'' = 17''$$

$$\textcircled{1} = 2'' + 9 @ 4'' = 38''$$

$$\textcircled{2} = 8 @ 8'' = 64'' \\ \hline 81''$$

$$\textcircled{2} = 4 @ 5\frac{1}{2}'' = 22''$$

$$\textcircled{3} = 6 @ 8'' = 48'' \\ \hline 108''$$

4.9

COMPRESSIVE FORCE $N_u = 88$ KIPS ADDED TO PROBLEM 4.2

(a) MORE ACCURATE EQUATION:

$$M_m = M_u - N_u \left(\frac{4h-d}{8} \right) = 73.5 \times 12 - 88 \left(\frac{4 \times 20 - 17.5}{8} \right) = 195 \text{ KIP-FT}$$

$$\frac{V_u d}{M_m} = \frac{45.0 \times 17.5}{195} = 4.04$$

$$V_c = \left(1.9 \sqrt{4000} + 2500 \times 0.0171 \times 4.04 \right) \frac{10 \times 17.5}{1000} \\ = 51.3 \text{ KIPS}$$

$$\text{LIMIT: } V_c \leq 3.5 \sqrt{f'_c} b_w d \sqrt{1 + \frac{N_u}{500 A_g}} \\ \leq 3.5 \frac{\sqrt{4000}}{1000} 10 \times 17.5 \sqrt{1 + \frac{88,000}{500 \times 10 \times 20}} = 53.1 \text{ KIPS}$$

(b) APPROXIMATE EQUATION:

$$V_c = 2 \left(1 + \frac{N_u}{2000 A_g} \right) \sqrt{f'_c} b_w d, \quad N_u \text{ in PSI} \\ = 2 \left(1 + \frac{88,000}{2000 \times 10 \times 20} \right) \sqrt{4000} \times \frac{10 \times 17.5}{1000} = 27.0 \text{ KIPS}$$

THE AXIAL FORCE REDUCES THE LENGTH OVER WHICH SHEAR REINFORCEMENT IS NEEDED -

$$\text{PREVIOUS } V_c \text{ (W/O AXIAL FORCE)} = 2 \sqrt{f'_c} b_w d \\ = \frac{2 \sqrt{4000} \times 10 \times 17.5}{1000} = 22.1 \text{ KIPS}$$

4.10

TENSION FORCE $N_u = -44$ KIPS ADDED TO PROBLEM 4.2

(a) MORE ACCURATE EQUATION:

$$V_c = Z \left(1 + \frac{N_u}{500 A_g} \right) \sqrt{f'_c} b_w d$$

WHERE N_u IS NEGATIVE FOR TENSION + $\frac{N_u}{A_g}$ IS IN PSI

$$\begin{aligned} V_c &= Z \left(1 + \frac{-44,000}{500 \times 10 \times 20} \right) \frac{\sqrt{4000} \cdot 10 \times 17.5}{1000} \\ &= 12.4 \text{ KIPS} \end{aligned}$$

(b) APPROXIMATE APPROACH:

$$V_c = 0 \quad \text{WEB STEEL TAKES THE TOTAL SHEAR AS SUGGESTED IN ACI COMMENTARY R 11.2.2.3}$$

4.11

REDDESIGN SHEAR REINFORCEMENT FOR BEAM IN PROBLEM 4.2 USING MCFT

$$d_v = 0.9d = 0.9 \times 17.5 = 15.75''$$

$$\text{CRITICAL SECTION @ } d_v = 15.75'' = 1.31'$$

$$V_{u,d} = 55.8 - 7.44 \times 1.31 = 46.1 \text{ KIPS}$$

$$0.125 f'_c b_v d_v = \frac{0.125 \times 4000 \times 10 \times 15.75}{1000} = 78.8 \text{ KIPS}$$

THEREFORE,

$$S_{\text{MAX}} \leq 0.8d_v = 12.6'' \leftarrow \text{CONTROLS}$$

$$\leq 24''$$

$$\leq \frac{A_v f_{yt}}{\sqrt{f'_c} b_v} = \frac{0.22 \times 60,000}{\sqrt{4000} \cdot 10} = 20.9''$$

$$\epsilon_s = \frac{M_u / d_v + V_u}{\epsilon_s \times A_s} = \frac{M_u / 15.75 + V_u}{29,000 \times 3.00}$$

M_u must be $\geq V_u d_v$ in expression for ϵ_s

$$\beta = \frac{4.8}{1 + 750 \epsilon_s}$$

$$\ominus = 29 + 3500 \epsilon_s$$

$$V_c = \beta \sqrt{f'_c}$$

$$V_s = \frac{V_u - \phi V_c}{\phi}$$

(a)

$\phi = 0.9$ for shear

Distance from Support, ft	M_u , ft-kips	V_u , kips	$\epsilon_s \times 1000$	θ	ϕV_c for at Least Minimum Stirrups				ϕV_c for Less Than Minimum Stirrups		
					β	ϕV_c , kips	V_s , kips	s , in.	β	ϕV_c , kips	$\phi V_c/2$, kips
0	0	55.8	1.28	33.5	2.45	21.9	37.7	8.3	2.28	20.4	10.2
1	52	48.4	1.11	32.9	2.62	23.5	27.7	11.6	2.44	21.9	10.9
1.31*	67	46.1	1.11	32.9	2.61	23.4	25.2	12.8	2.44	21.8	10.9
2	97	40.9	1.32	33.6	2.41	21.6	21.4	14.6	2.25	20.2	10.1
3	134	33.5	1.56	34.5	2.21	19.8	15.2	20.0	2.06	18.5	9.2
4	164	26.1	1.73	35.1	2.09	18.7	8.2	36.3	1.94	17.4	8.7
5	186	18.6	1.84	35.5	2.01	18.1	0.6	477.6	1.88	16.8	8.4
6	201	11.2	1.89	35.6	1.99	17.8	--	--	1.85	16.6	8.3
7	208	3.7	1.87	35.5	2.00	17.9	--	--	1.86	16.7	8.3
7.5	209	0.0	1.83	35.4	2.02	18.1	--	--	1.88	16.9	8.4

* d_v from face of support

SELECT PRACTICAL SPACING —

4.11 continued

(6)

$\phi = 0.75$ for shear

Distance from Support, ft	M_u , ft-kips	V_u , kips	$\epsilon_s \times 1000$	θ	ϕV_c for at Least Minimum Stirrups			ϕV_c for Less Than Minimum Stirrups			
					β	ϕV_c , kips	V_s , kips	s , in.	β	ϕV_c , kips	$\phi V_c/2$, kips
0	0	55.8	1.28	33.5	2.45	18.3	41.7	7.5	2.28	17.0	8.5
1	52	48.4	1.11	32.9	2.62	19.6	32.0	10.0	2.44	18.2	9.1
1.31*	67	46.1	1.11	32.9	2.61	19.5	29.5	10.9	2.44	18.2	9.1
2	97	40.9	1.32	33.6	2.41	18.0	25.5	12.3	2.25	16.8	8.4
3	134	33.5	1.56	34.5	2.21	16.5	18.8	16.1	2.06	15.4	7.7
4	164	26.1	1.73	35.1	2.09	15.6	11.6	25.5	1.94	14.5	7.3
5	186	18.6	1.84	35.5	2.01	15.0	4.0	73.8	1.88	14.0	7.0
6	201	11.2	1.89	35.6	1.99	14.8	--	--	1.85	13.8	6.9
7	208	3.7	1.87	35.5	2.00	14.9	--	--	1.86	13.9	7.0
7.5	209	0.0	1.83	35.4	2.02	15.1	--	--	1.88	14.1	7.0

* d_v from face of support

SELECT PRACTICAL SPACING

4.12

Redesign shear reinforcement for beam
in Problem 4.4 using MFCT

$$d_v = 0.9d = 0.9 \times 31 = 27.9''$$

$$\text{Critical section @ } d_v = 27.9'' = 2.33 \text{ ft}$$

$$V_u @ d_v = 141.4 - 11.78 \times 2.33 = 113.9 \text{ kips}$$

$$0.125 f'_c b_v d_v = \frac{0.125 \times 5000 \times 14 \times 27.9}{1000} = 244.1 \text{ kips}$$

$$\text{Therefore, } S_{\max} \leq 0.8 d_v = 22.3''$$

$$\leq 24''$$

$$\leq \frac{A_v f_y t}{\sqrt{f'_c} b_v} = \frac{0.40 \times 60,000}{\sqrt{5000} \times 14} = 24.2''$$

$$E_s = \frac{M_u / d_v + V_u}{E_s \times A_s} = \frac{M_u / 27.9 + V_u}{29,000 \times 7.62}$$

M_u must be $\geq V_u d_v$ in expression for E_s

Results on Page 4-14

(a) 4.12 continued

$\phi = 0.9$ for shear

Distance from Support, ft	M_u , ft-kips	V_u , kips	$\epsilon_s \times 1000$	θ	ϕV_c for at Least Minimum Stirrups				ϕV_c for Less Than Minimum Stirrups		
					β	ϕV_c , kips	V_s , kips	s , in.	β	ϕV_c , kips	$\phi V_c/2$, kips
0	0	141.4	1.28	33.5	2.45	30	89.4	6.2	1.87	41.5	20.8
1	135	129.6	1.17	33.1	2.55	32	73.4	7.7	1.95	43.3	21.6
2	259	117.8	1.07	32.7	2.67	33	57.2	10.0	2.03	45.2	22.6
2.33*	297	113.9	1.09	32.8	2.64	33	53.8	10.6	2.01	44.7	22.3
3	371	106.0	1.20	33.2	2.52	31	48.1	11.7	1.92	42.8	21.4
4	471	94.2	1.34	33.7	2.39	30	38.7	14.3	1.82	40.5	20.3
5	560	82.5	1.46	34.1	2.29	28	28.4	19.1	1.75	38.8	19.4
6	636	70.7	1.56	34.5	2.21	28	17.4	30.9	1.69	37.5	18.8
7	701	58.9	1.63	34.7	2.16	27	5.8	91.5	1.65	36.6	18.3
8	754	47.1	1.68	34.9	2.12	26	--	--	1.62	36.0	18.0
9	795	35.3	1.71	35.0	2.10	26	--	--	1.60	35.7	17.8
10	825	23.6	1.71	35.0	2.10	26	--	--	1.60	35.6	17.8
11	842	11.8	1.69	34.9	2.11	26	--	--	1.61	35.8	17.9
12	848	0.0	1.65	34.8	2.14	27	--	--	1.63	36.4	18.2

* d_v from face of support

(b)

$\phi = 0.75$ for shear

Distance from Support, ft	M_u , ft-kips	V_u , kips	$\epsilon_s \times 1000$	θ	ϕV_c for at Least Minimum Stirrups				ϕV_c for Less Than Minimum Stirrups		
					β	ϕV_c , kips	V_s , kips	s , in.	β	ϕV_c , kips	$\phi V_c/2$, kips
0	0	141.4	1.28	33.5	2.45	50.7	5.5	141.4	1.87	34.6	17.3
1	135	129.6	1.17	33.1	2.55	52.9	6.6	129.6	1.95	36.1	18.0
2	259	117.8	1.07	32.7	2.67	55.3	8.2	117.8	2.03	37.7	18.8
2.33*	297	113.9	1.09	32.8	2.64	54.6	8.7	113.9	2.01	37.2	18.6
3	371	106.0	1.20	33.2	2.52	52.3	9.4	106.0	1.92	35.7	17.8
4	471	94.2	1.34	33.7	2.39	49.5	11.1	94.2	1.82	33.8	16.9
5	560	82.5	1.46	34.1	2.29	47.4	14.0	82.5	1.75	32.3	16.2
6	636	70.7	1.56	34.5	2.21	45.9	19.5	70.7	1.69	31.3	15.6
7	701	58.9	1.63	34.7	2.16	44.7	33.8	58.9	1.65	30.5	15.2
8	754	47.1	1.68	34.9	2.12	44.0	7	47.1	1.62	30.0	15.0
9	795	35.3	1.71	35.0	2.10	43.6	--	--	1.60	29.7	14.9
10	825	23.6	1.71	35.0	2.10	43.5	--	--	1.60	29.7	14.8
11	842	11.8	1.69	34.9	2.11	43.8	--	--	1.61	29.9	14.9
12	848	0.0	1.65	34.8	2.14	44.4	--	--	1.63	30.3	15.1

* d_v from face of support

Select practical spacings

4.13

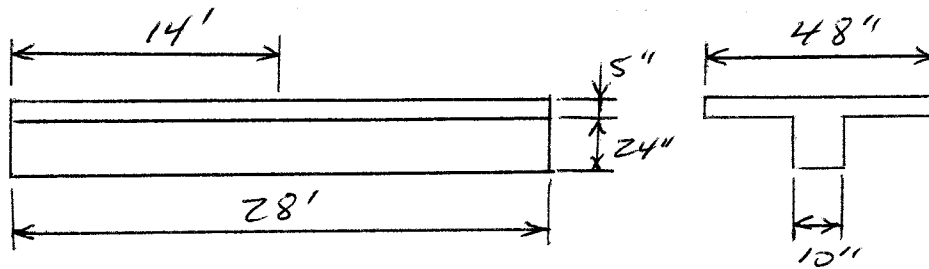

$$V_u = 2400 \times \frac{48 \times 5}{1000} = 576 \text{ KIPS}$$

$$\begin{aligned} \phi V_m &\leq \phi 0.2 f'_c A_c = 0.75 \times 4000 \times 14 \times 12 \times 10 / 1000 = 5040 \text{ KIPS} \\ &\leq \phi (480 + 0.08 f'_c) A_c = 0.75 (480 + 0.08 \times 4000) 1680 / 1000 \\ &= 1008 \text{ KIPS} \\ &\leq \phi 1600 A_c = 0.75 \times 1600 \times 1680 / 1000 = 2016 \text{ KIPS} \end{aligned}$$

OK

$$A_{vf} = \frac{V_u}{\phi \mu f_v} = \frac{576}{0.75 \times 1.0 \times 60} = 12.8 \text{ in}^2$$

$$n = \frac{12.8}{0.40} = 32$$

Need 32 \sqsubset No. 4 (No. 13) stirrups
for each half span.

Instructor's Solutions Manual

to accompany

Design of Concrete Structures, 14e

Nilson/Darwin/Dolan

Chapters 5-9

The authors welcome feedback on the problem solutions and on the text in general. Please e-mail any comments to David Darwin at: daved@ku.edu

PROPRIETARY AND CONFIDENTIAL

This Manual is the proprietary property of The McGraw-Hill Companies, Inc. ("McGraw-Hill") and protected by copyright and other state and federal laws. By opening and using this Manual the user agrees to the following restrictions, and if the recipient does not agree to these restrictions, the Manual should be promptly returned unopened to McGraw-Hill: This Manual is being provided only to authorized professors and instructors for use in preparing for the classes using the affiliated textbook. No other use or distribution of this Manual is permitted. This Manual may not be sold and may not be distributed to or used by any student or other third party. No part of this Manual may be reproduced, displayed or distributed in any form or by any means, electronic or otherwise, without the prior written permission of the McGraw-Hill.

S.1

(a)

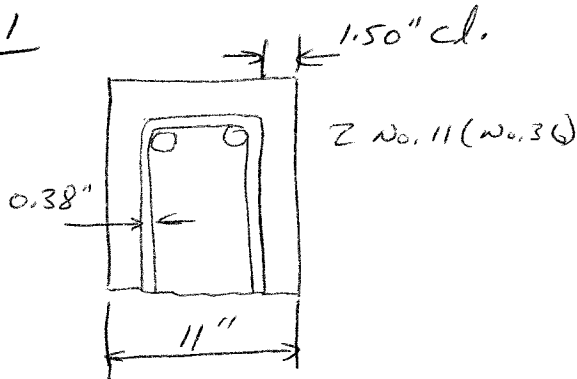

CLEAR SPACING OF No. 11
 $= 11.00 - 2(1.50 + 0.38 + 1.41)$
 $= 4.42" > 1.41"$

CLEAR COVER OF No. 11
 $= 1.50 + 0.38 = 1.88" > 1.41"$

+ STRUTS \geq MIN BY CODE

$$l_d = \left(\frac{f_y \psi_t \psi_e}{20 \lambda \sqrt{f'_c}} \right) d_b = \left(\frac{60,000 \times 1.3 \times 1}{20 \times 0.75 \sqrt{4000}} \right) 1.41 = 115"$$

BUT FOR $w_u = 656 \text{ kips/ft}$; $M_u = 210 \text{ ft-k}$; $A_{s, req'd} = 2.45 \text{ in}^2$ VS $A_{s, provided} = 3.12 \text{ in}^2$

REDUCED $l_d = 115 \times \frac{2.45}{3.12} = 96"$, OK BY 3"

(b) DISTANCE TO NEAREST FACE = 2.58"

CENTRAL LINE SPACE $\times \frac{1}{2} = (4.42 + 1.41) \frac{1}{2} = 2.92"$

$\therefore c = 2.58"$

$k_{cr} = \frac{A_{tr}}{40 s_m} = \frac{0.22}{40 \times 10.5 \times 2} = 0.42$; $\frac{c + k_{cr}}{d_b} = 2.12$

$$l_d = \left(\frac{3}{40} \frac{f_y}{\lambda \sqrt{f'_c}} \frac{\psi_t \psi_e \psi_s}{c + k_{cr}} \right) d_b = \frac{3 \times 60,000}{40 \times 0.75 \sqrt{4000}} \times \frac{1.3 \times 1 \times 1}{2.12} \times 1.41 = 82"$$

REDUCED $l_d = 82 \times \frac{2.45}{3.12} = 64"$ - SIGNIFICANTLY LESS -

(c) FOR STRAIGHT BARS: $l_d = 64 \frac{\sqrt{4000}}{\sqrt{5000}} = 57" > 18"$

\therefore NEED HOOKS:

$$l_{dh} = \left(\frac{0.02 \psi_e f_y}{\lambda \sqrt{f'_c}} \right) d_b = \left(\frac{0.02 \times 1 \times 60,000}{1 \times \sqrt{5000}} \right) 1.41 = 24" > 18"$$

BUT CAN MODIFY

$$l_{dh} = 24 \times 0.7 \times \frac{2.45}{3.12} = 13" < 18" \text{ SO OK!}$$

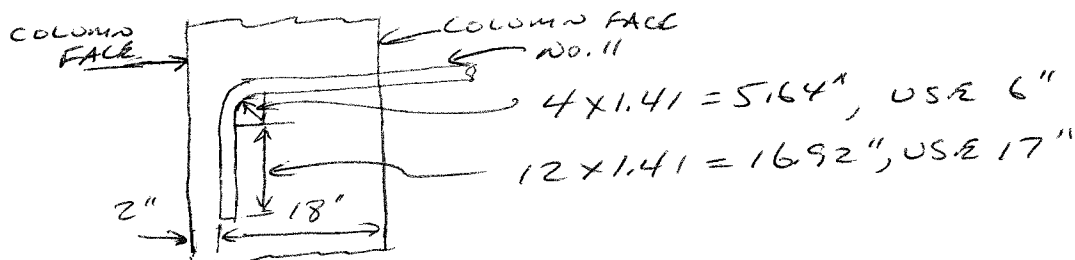

5.2

$$W_u = 1.2 \times 1.05 + 1.6 \times 1.62 = 3.85 \text{ Kips/ft}$$

$$M_u = \frac{1}{8} \times 3.85 \times 27^2 = 351 \text{ K}$$

$$\frac{M_u}{\phi b d^2} = \frac{351 \times 12000}{0.9 \times 22 \times 16^2} = 831 \rightarrow \rho = 0.0155$$

$$\text{REQ'D } A_s = 5.46 \text{ in}^2$$

$$\text{PROV'D } A_s = 6.35 \text{ in}^2$$

$$\text{Three No. 10 : } A_s = 3.81 \text{ in}^2, \rho = 0.0108$$

$$(a) \frac{M_u}{\phi b d^2} = 599$$

$$M_u = \frac{599 \times 0.9 \times 22 \times 16^2}{12000} = 253 \text{ K}$$

$$\frac{253}{351} = 0.72$$

SO TWO NO. 10S COULD BE CUT
AT $0.23 \times 27 = 6.21'$ FROM
SUPPORT ζ (GRAPH A.2)

$$\text{ADD: } d = 1.33'$$

← CONTROLS

$$\text{OR } 12d_b = \frac{12 \times 1.27}{12} = 1.27'$$

$$\text{ACTUAL CUT POINT} = 6.21 - 1.33 = 4.88'$$

FROM SUPPORT ζ

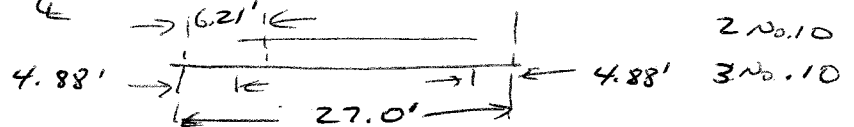

(b) FOR NO. 10 BARS, $l_d = 53''$ (TABLE A.10)

$$\text{FOR NO. 10 CUT BAR, REDUCED } l_d = 53 \frac{5.46}{6.35} = 46'' = 3.8'$$

$$\text{HAVE } (27 - 2 \times 4.88) / 2 = 8.62' > 3.8' \text{ OK}$$

FOR NO. 10 CONTINUOUS BARS, HAVE

$$6.21 \times 12 + 4 = 79'' - \text{NEED } 60'' \text{ OK}$$

$$(c) M_u = \frac{253}{0.9} = 281 \text{ KIPS}$$

$$V_u = \frac{1}{2} \times 3.85 \times 27.0 = 52.0 \text{ KIPS}$$

$$\therefore l_d \leq 1.3 \frac{281 \times 12}{52.0} + 4 = 88'', + l_d = 60''$$

SATISFIES THIS REQUIREMENT —

5.2 CONTINUED

(d) V_u @ THEORETICAL CUT POINTS

$$= 3.85 \times \frac{1}{2} \times 27.0 - 3.85 \times 4.88 = 33.2 \text{ KIPS}$$

$$\phi V_c = 0.75 \times 2 \sqrt{5000} \times \frac{22 \times 16}{1000} = 37.3 \text{ KIPS}$$

SINCE $V_u > \frac{1}{2} \phi V_c$, REQUIRED MINIMUM SHEAR

REINF. GIVES $S \leq \frac{0.22 \times 60000}{0.75 \sqrt{5000} \times 22} = 11.3 \rightarrow 11 \text{ in.}$

$$S \leq \frac{0.22 \times 60000}{50 \times 22} = 12.0''$$

ALSO, MUST USE EXTRA No. 3 U STIRRUPS OVER

$$\text{DISTANCE} = \frac{3}{4} \times 16 = 12'' \text{ AT MAXIMUM SPACING}$$

$$\frac{d}{8\beta d} = \frac{16}{8 \times 0.33} = 6'' \text{ SAY 3 No. 3 @ 6''}$$

(e)
$$\frac{2 \text{ No. 10 @ } 207''}{3 \text{ No. 10 @ } 332''}$$

$$\text{STEEL USED} = 1410'' \\ \text{VS. } 5 \times 332 = 1660''$$

THIS SAVES 15% STEEL —

BUT HAVE LENGTHED CALCULATIONS
CONSIDERABLY (COST \$ FOR LENGTH) AND
COMPLICATED STEEL PLACEMENT

IF ONLY ONE BEAM TO BE BUILT, CARRY
ALL BARS THROUGH; IF MANY REPEATITIONS,
CUT TWO No. 10

SEPARATE CALCULATIONS CORRESPONDING TO
(b) & (c) INDICATE THAT THE REQUIRED
 l_d COULD NOT BE ACCOMMODATED
THREE No. 10 BARS WERE CUT —

5.3

SPLICE LENGTH

For bars of different size spliced in compression, the splice length is the larger of l_{dc} of the larger bar and the compression lap length of the smaller bar - per ACI Code 12.6.2.

l_{dc} for No. 10 bars:

$$l_{dc} = \left(\frac{0.02 f_y}{\lambda \sqrt{f_c}} \right) d_b = \left(\frac{0.02 \times 75000}{1.0 \sqrt{8000}} \right) 1.27 = 21''$$

$$l_{dc} = 0.0003 f_y d_b = 0.0003 \times 75000 \times 1.27 = 29'' \leftarrow \text{CONTROLS}$$

Applying the reduction factors for steel area and spiral reinforcement:

$$l_{dc} = 29 \times \frac{5.80}{7.59} \times 0.75 = 16.6''$$

$\geq 12''$

lap length for No. 9 bars ($f_y > 60,000 \text{ psi}$)

$$\begin{aligned} \text{lap} &= (0.0009 f_y - 24) d_b \\ &= (0.0009 \times 75000 - 24) 1.128 = 49'' \end{aligned}$$

Applying the reduction for spiral reinforcement,

$$49 \times 0.75 = 36.75''$$

USE 37'' LAP

5.4

FOR NO. 8 BARS:

$$\text{CLEAR SPACE} = (10 - 4 - 3) \frac{1}{2} = 1.5" > d_b$$

$$\text{CLEAR COVER} = 2" > d_b$$

ASSUME NO. 3 STRAPUPS -

$$\therefore \text{FROM TABLE A.10, } l_d/d_b = 62$$

$$l_d = 62 \times 1 = 62"$$

BUT WE HAVE ONLY $40 - 2 = 38"$

SO WE NEED TO USE A 90° HOOK

FOR HOOKED BARS:

$$l_{dL} = \left(\frac{0.02A}{\lambda \sqrt{f_c}} \right) d_b = \left(\frac{0.02 \times 1}{1 \times \sqrt{4000}} \right) 1 = 19"$$

NO MODIFICATION FACTOR - $19" < 38"$ OK!

BUT WE ALSO NEED TRANSVERSE STEEL ACCORDING TO ACI -

$$\text{MAX SPACING} = 3 \times 1.0 = 3"$$

OVER DISTANCE $l_{dL} = 19"$, USE 6 NO. 3 @ 3"

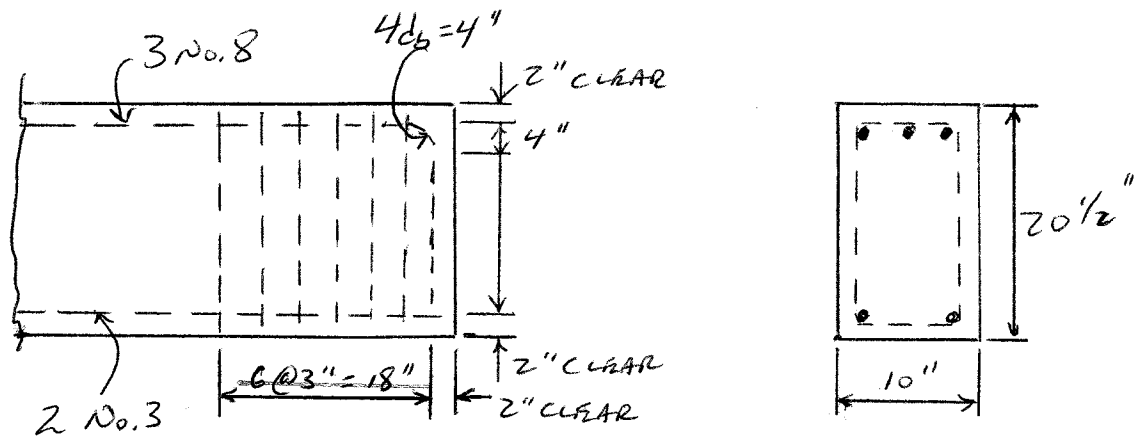

CHECK VERTICAL CLEARANCE:

$$2 + \frac{3}{8} + 4 + 12 + 2 = 20 \frac{3}{8}" < 20 \frac{1}{2}"$$

5.5

ASSUME NO. 8 BARS ARE FULLY STRESSED

BY APPROX. EQ. (5.5a)

$$\text{CLEAR COVER} = 3.5" > d_b$$

$$\text{CLEAR SPACING} = 15" > 2d_b$$

$$l_d = \left(\frac{f_y \psi_t \psi_e}{20 \lambda \sqrt{f_c}} \right) d_b = \left(\frac{60000 \times 1 \times 1}{20 \times 1 \sqrt{4000}} \right) 1 = 47"$$

$$> (27-2) = 25" \text{ SO NEED HOOKS}$$

BUT TRY BASIC EQ. (5.4) FOR THIS CASE

$$C = 4"$$

$$k_{tr} = 0 \quad \frac{C + k_{tr}}{d_b} = \frac{4}{1} = 4.00, \text{ BUT}$$

MUST BE ≤ 2.5 ← CONTROLS

$$l_d = \left(\frac{3}{40} \frac{60000 \times 1 \times 1 \times 1}{\sqrt{4000} \times 2.5} \right) \times 1 = 28"$$

BETTER, BUT STILL $> 25"$

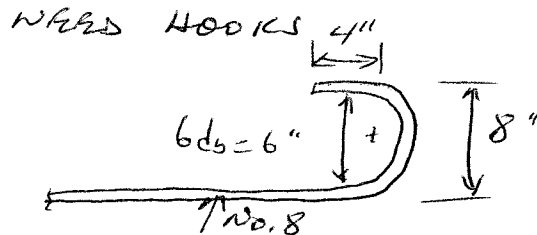

AN ALTERNATE WOULD BE TO USE NO. 7

BAR @ 12.15", SAY 12" ON CENTERS —

$$\text{THIS GIVES } 0.60 \times \frac{12}{12} = 0.60 \text{ in}^2/\text{ft} \text{ —}$$

5.6

$$l_{dc} = \left(\frac{0.016 \psi_e f_y}{\sqrt{f'c}} \right) = \left(\frac{0.016 \times 1 \times 60000}{\sqrt{5000}} \right) 0.125$$

$$= 8.5 \text{ in} \leftarrow \text{controls}$$

$$\geq 8d_b = 5 \text{ in.}$$

$$\geq 6 \text{ in}$$

Minimum width of closure strip
 $= 8.5 + 2(1.0 + 0.5) = 11.5 \text{ in.}$

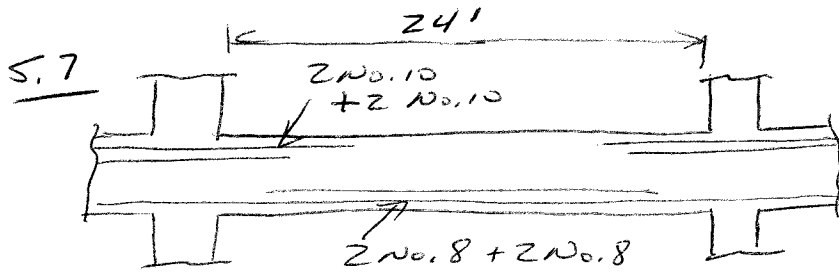

$$b = 14", d = 22"$$

$$-M_u = \frac{1}{11} \times 7.9 \times 24^2 = 4141 \text{ KIPS}$$

$$+M_u = \frac{1}{16} \times 7.9 \times 24^2 = 2841 \text{ KIPS}$$

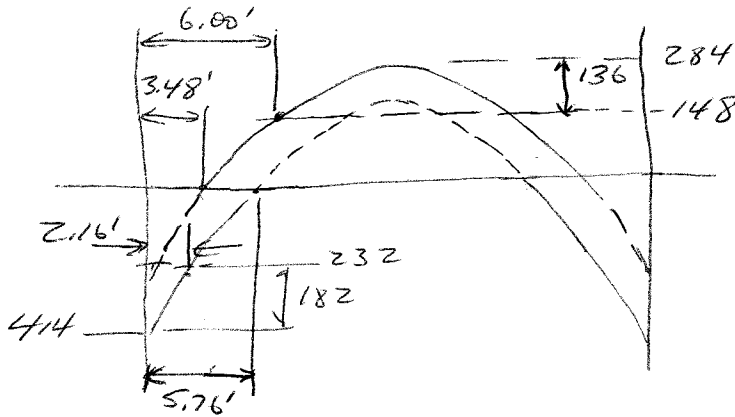

FIND IP LOCATIONS AND THEORETICAL CUTOFF POINTS FROM GRAPH A3

4 No. 8 = 3.16 in ²	$\rho = 0.0102$	$\phi M_n = 0.9 \times 557 \times 14 \times 22^2 / 12000 = 2841 \text{ K}$
2 No. 8 = 1.58	= 0.0051	= 0.9 \times 292 \times 14 \times 22^2 / 12000 = 148
4 No. 10 = 5.08	= 0.0164	= 0.9 \times 842 \times 14 \times 22^2 / 12000 = 428
2 No. 10 = 2.54	= 0.0082	= 0.9 \times 456 \times 14 \times 22^2 / 12000 = 232

PDS. BARS EXTEND $\left\{ \begin{array}{l} 12 \times 1 = 12" \\ d = 22" \end{array} \right\}$ PAST THEO. POINT -
 FROM GRAPH A3 WITH CUTOFF OF 136/284 = 48%
 THEORETICAL CUTOFF POINT = 0.25 \times 24 = 6' FROM SUPPORT
 ACTUAL = 72 - 22 = 50" FROM SPT -
 OTHER TWO NO. 8 CALLING THROUGH SUPPORT FOR CONTINUITY

NEG. BARS EXTEND $\left\{ \begin{array}{l} 12 \times 1.27 = 15" \\ d = 22" \end{array} \right\}$ PAST THEO. POINT -
 FROM GRAPH A3 WITH CUTOFF OF 182/414 = 44%
 THEORETICAL CUTOFF POINT = 0.09 \times 24 = 2.16' FROM SPT.
 $l_d = 48 \times 1.3 = 62"$ CONTROLS

CARRYING REMAINING TWO NO. 10 $d = 22"$, $12d_b = 15"$
 PAST IP, BUT NOT LESS THAN $l/16 = 18"$, $22"$ CONTROLS
 AND STOP REMAINING NO. 10'S AT $5.76 \times 12 + 22 = 91"$ FROM SUPPORT

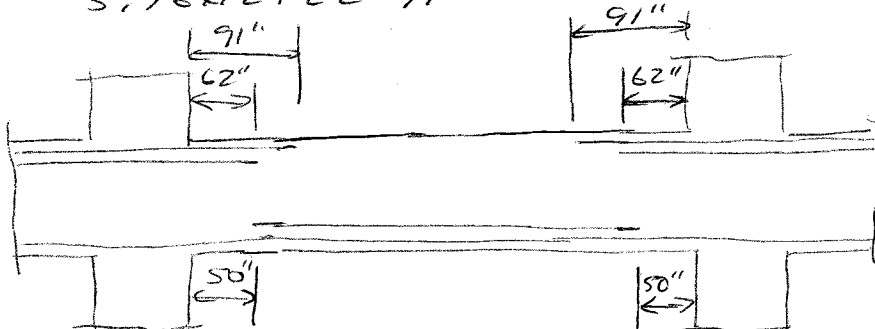

S. 7 CONTINUED

CHECK CONDITIONS AT INFLECTION POINT:

$$M_u = 148 \text{ KIPS FOR 2 NO. 8}$$

$$R_u = 7.9 \times 12 = 94.8 \text{ KIPS}$$

$$V_u = 94.8 - 7.9 \times 3.48 = 67 \text{ KIPS}$$

$$l_a \leq \begin{cases} d = 22" \leftarrow \\ 12d_b = 12" \end{cases}$$

$$\text{SO } l_d \leq \frac{M_u}{V_u} + l_a = \frac{148}{67} + \frac{22}{12} = 4.04' = 49"$$

CHECK NO. 8 $l_d = 47" < 49"$ OK

ALSO, SINCE NO. 8 BARS ARE CUTOFF IN TENSION ZONE, WILL NEED EXTRA STIRRUPS. CALCULATIONS INDICATE FOUR NO. 3 NEEDED, EQUALLY SPACED OVER $\frac{3}{4}d = 16.5"$

FINAL COMMENT; BECAUSE OF LENGTHY CALCULATIONS, COMPLICATED STEEL PLACEMENT, NEED FOR EXTRA STIRRUPS, AND SMALL DIFFERENCE IN TOTAL STEEL, MOST ENGINEERS WOULD CARRY ALL POS. BARS THROUGHOUT THE SPAN AND CUT ALL NEG. BARS AT 9' -

ALSO NOTE THAT FIG. 5.20 GIVES GOOD RESULTS HERE -

5.8

$$M_u = 465 \times 8 = 3720 \text{ ft-kips} = 44,160 \text{ in-kips}$$

(NEGLECTING SELF WEIGHT)

$$A_s = 18.72 \text{ in}^2; a = \frac{18.72 \times 60}{0.85 \times 22 \times 5} = 12 \text{ in}$$

$$\phi M_n = 0.9 \times 18.72 \times 60 (50 - 6) = 44,478 \text{ in-kips}$$

$$\frac{\phi M_n}{M_u} = 0.9964 \text{ OK} - - \text{STEEL FULLY STRESSED}$$

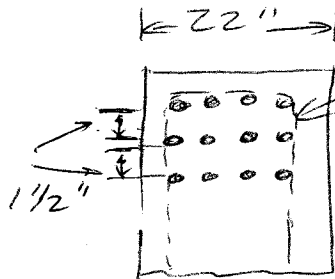

ASSUME
MINIMUM
STIRRUPS (NO. 5 BARS)

$$\text{SPACING} = \frac{1}{3} (22 - 2(1.5 + \frac{5}{8} + 2 \times 1.41))$$
$$= 4.0 \text{ in OK}$$

$$l_d = \left(\frac{60000 \times 1.3 \times 1.41}{20 \times 1 \sqrt{5000}} \right) 1.41 = 78 \text{ in} = 6.48 \text{ ft}$$

$$\text{CLASS B SPACE} = 1.3 \times 78 = 101 \text{ in}$$

SPECIAL ANCHORAGE SHOULD NOT BE NEEDED
IF MINIMUM STIRRUPS PROVIDED -

6.1

(a) $b = 12''$
 $d = 20.5''$
 $h = 23''$
 $l = 18.5'$
 $A_s = 2.40 \text{ in}^2$

$$\rho = \frac{A_s}{bd} = \frac{2.40}{15 \times 20.5} = 0.0078$$

$$E_s = 29 \times 10^3 \text{ ksi}$$

$$E_c = 57 \sqrt{4000} = 3.6 \times 10^3 \text{ ksi}$$

$$n = 8$$

$$k = \sqrt{(\rho n)^2 + 2\rho n} - \rho n = 0.296$$

$$j = 1 - k/3 = 0.901$$

AT SERVICE LOAD $w_s = 3.37 \text{ kips/ft}$

$$M_s = 3.37 \times \frac{18.5^2}{8} = 144 \text{ kips}$$

$$f_s = \frac{M}{A_s j d} = \frac{144 \times 12}{2.40 \times 0.901 \times 20.5} = 39.0 \text{ ksi}$$

$$k_d = 0.296 \times 20.5 = 6.07''$$

$$h_z = 23 - 6.07 = 16.93''$$

$$h_i = 16.93 - 2.5 = 14.43''$$

$$\beta = \frac{h_z}{h_i} = 1.17 \quad A = \frac{5 \times 15}{4} = 18.75$$

$$w = 0.076 \times 1.17 \times 39.0 \sqrt[3]{2.5 \times 18.75} = 12.5 \text{ OR } 0.0125''$$

(b)

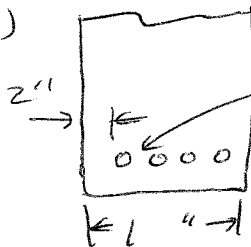

LINEAR SPACING = 2.5"
 SPACING = 3.5"

$$\text{Eq. (6.3)} : S = 15 \left(\frac{40000}{f_s} \right) - 2.5$$

$$= 15 \left(\frac{40000}{39000} \right) - 2.5 \times 10 = 10.4''$$

$$> 3.5'' \quad \text{OK}$$

6.2

$$A_s = 2 \times 1.00 = 2.00 \text{ in}^2$$

$$\rho = \frac{2.00}{15 \times 20.5} = 0.0065$$

$$n = 8$$

$$k = 0.275$$

$$j = 0.9083$$

$$f_s = \frac{144 \times 12}{2.00 \times 0.9083 \times 20.5} = 46.4 \text{ ksi}$$

$$s = 15 \left(\frac{40000}{46400} \right) - 2.5 \times 2 = 7.93''$$

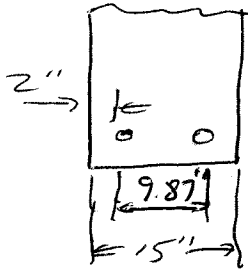

$$\text{Spacing} = 15 - 4 - 1.128 = 9.87'' > 7.93''$$

NO GOOD

Because s is greater than the allowable spacing, at least three bars are needed. Three No. 8 (No. 25) Grade 60 bars would cut the spacing and provide nearly the same steel area (2.37 vs 2.40) as the four No. 7 (No. 22) bars without requiring the use of higher strength steel.

6.3

$b = 15"$ $w_o + w_d = 1.08 \text{ K/ft}$
 $d = 20.5"$ $w_l = 2.29 \text{ K/ft}$
 $h = 23"$ $k = 0.296$
 $A_s = 240 \text{ in}^2$ $k_d = 6.07"$
 $n = 8$ $\lambda = 0.901$

$f_y = 60 \text{ KSI}$
 $f'_c = 4 \text{ KSI}$
 $f_r = 7.5 \sqrt{f'_c} = 474 \text{ psi}$

$M_d = 1.08 \times 18.5^2 / 8 = 462.1 \text{ KIPS}$
 $M_{d+l} = 3.37 \times 18.5^2 / 8 = 1442.1 \text{ KIPS}$

$I_g = \frac{1}{12} \times 12 \times 23^3 = 12200 \text{ in}^4$

$I_{CT} = \frac{1}{3} \times 12 \times 6.07^3 + 25.28 \times 14.43^2 = 5278 \text{ in}^4$

$M_{cr} = \frac{0.474 \times 12200}{11.5 \times 12} = 41.9 \text{ KIPS}$

(a) For $w_o + w_d$:
 $\left(\frac{M_{cr}}{M_d}\right)^3 = \left(\frac{41.9}{462.1}\right)^3 = 0.746$

$I_e = (0.746 \times 12200) + (0.254 \times 5278)$
 $= 10442 \text{ in}^4$

$\Delta_{i,d} = \frac{5}{384} \frac{w_l l^4}{E_c I_e} = \frac{5 \times 1.27 (18.5 \times 12)^4}{384 \times 3.6 \times 10^3 \times 10442 \times 12}$
 $= 0.08"$

For $w_o + w_d + w_l$:
 $\left(\frac{M_{cr}}{M_a}\right)^3 = \left(\frac{41.9}{1442.1}\right)^3 = 0.025$

$I_e = (0.025 \times 12200) + (0.975 \times 5278)$
 $= 5451 \text{ in}^4$

$\Delta_{i,d+l} = \frac{5 \times 3.37 (18.5 \times 12)^4}{384 \times 3.6 \times 10^3 \times 5451 \times 12}$
 $= 0.45"$

Thus, $\Delta_{i,l} = 0.45 - 0.08 = 0.37"$

(b) With $A_s' = 0$, $\lambda_e = 2.0 @ 54RS -$
 $\Delta_{cr} + \Delta_{i,l} = 0.08 \times 2 + 0.37 = 0.53"$

(c) BY ACI (Table 6.2)

$\Delta \leq \frac{18.5 \times 12}{480} = 0.46"$

SO BEAM DOES NOT QUITE SATISFY REQUIREMENTS - ALSO, WE WOULD PROBABLY BE APPLIED EARLY SO THAT $\Delta_d \lambda_e$ SHOULD BE BASED ON $I_e = 5451$ RATHER THAN 10442.

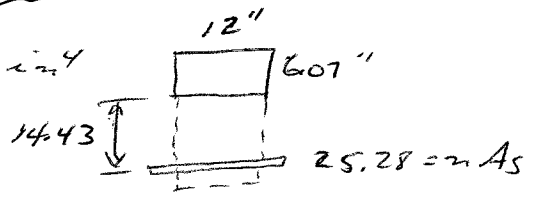

6.4

$$\begin{aligned} b &= 12'' & F_{c'} &= 3.6 \times 10^3 \text{ KSI} \\ d &= 20.5'' & \rho &= 0.018 \\ h &= 24'' & l &= 28' \\ A_s &= 4.68'' & K &= 0.412 \\ n &= 8 & K_d &= 0.412 \times 21.5 \\ & & &= 8.86'' \end{aligned}$$

LOADS

$$\left. \begin{aligned} W_D &= 390 \\ W_L &= 510 \\ W_{L,SUS} &= 400 \end{aligned} \right\} \text{SUSTAINED} = 1210 \text{ lb/ft}$$

$$\left. \begin{aligned} W_{L,ST} &= 1220 \end{aligned} \right\} \text{SHORT TERM} = 1220 \text{ lb/ft}$$

WITH ALL LOAD IN PLACE

$$M = \frac{1}{8} \times 2.43 \times 28^2 = 2381 \text{ KIPS}$$

$$I_g = \frac{1}{12} \times 12 \times 24^3 = 13800 \text{ in}^4$$

$$I_{cr} = \frac{1}{3} \times 12 \times 8.86^3 + 37.44 \times 12.64^2 = 8760 \text{ in}^4$$

$$M_{cr} = \frac{474 \times 13800}{12 \times 12000} = 45.4 \text{ K}$$

$$\left(\frac{M_{cr}}{M_a} \right)^3 = \left(\frac{45.4}{238} \right)^3 = 0.007 \rightarrow \therefore I_e \approx I_{cr} = 8760$$

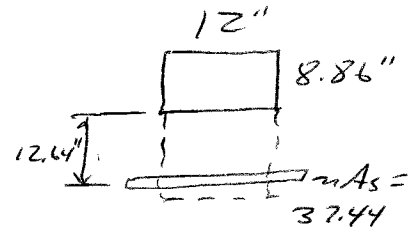

$$(a) \quad \Delta_{i,sus} = \frac{5 \times 1.21 (28 \times 12)^4}{384 \times 3.6 \times 10^3 \times 8760 \times 12} = 0.53''$$

$$\Delta_{cr,sus} = 0.53 \times 2.0 = 1.06''$$

$$(b) \quad \Delta_{i,ST} = 0.53 \times \frac{1220}{1210} = 0.53''$$

$$\Delta_{cr,sus} + \Delta_{i,ST} = 1.59''$$

From TABLE 6.2

$$L \leq \frac{28 \times 12}{240} = 1.40''$$

$$1.59 > 1.40 \leftarrow \text{NO GOOD}$$

THE BEST APPROACH WOULD BE TO ADD
A SMALL AMOUNT OF COMPRESSION
REINFORCEMENT -

6.5 TWO SPAN CONTINUOUS BEAM

$$\begin{aligned}
 b &= 10" & f_y &= 60 \text{ ksi} \\
 d &= 19\frac{1}{2}" & f'_c &= 5 \text{ ksi} \\
 h &= 22" & f_{ec} &= 4.03 \times 10^3 \text{ ksi} \\
 l &= 22' & f_r &= 530 \text{ psi} \\
 & & n &= 7.2 \\
 A_s^+ &= 2.00 & \rho^+ &= 0.0103 \\
 A_s^- &= 3.81 & \rho^- &= 0.0195
 \end{aligned}$$

$$\begin{aligned}
 \text{MAX MOMENT @ SUPPORT} &= \frac{1}{8} w l^2 \\
 \text{MAX POSITIVE MOMENT} &= \frac{9}{128} w l^2 \\
 \text{MAX DEFLECTION} &= \frac{1}{185} \frac{w l^4}{EI}
 \end{aligned}$$

$$\begin{aligned}
 (a) \quad M^- &= 60.5 \text{ 1-KIPS} \\
 M^+ &= 34 \text{ 1-KIPS}
 \end{aligned}
 \left. \begin{array}{l} \\ \end{array} \right\} \begin{array}{l} \text{DL} \\ \text{ONLY} \end{array}$$

$$I_g = \frac{10 \times 22^2}{12} = 8873 \text{ in}^4$$

$$M_{cr} = \frac{530 \times 8873}{11 \times 12000} = 35.6 \text{ 1-KIPS}$$

$$\begin{aligned}
 \text{AT EXT. SPT, } M_a &= 0, M_{cr} > M_a, I_e = I_g \\
 \text{AT MIDSPAN, } M_a &= 34, M_{cr} > M_a, I_e = I_g \\
 \text{AT INT. SPT, } M_a &= 60.5, M_{cr} < M_a, I_e < I_g
 \end{aligned}$$

$$\begin{aligned}
 n A_s &= 27.43 \text{ in}^2 \\
 K &= 0.4081, K_d = 7.96"
 \end{aligned}$$

$$\begin{aligned}
 I_{CT} &= \frac{1}{3} \times 10 \times 7.96^3 + 27.43 \times 11.54^2 \\
 &= 5334 \text{ @ INT. SPT}
 \end{aligned}$$

$$\begin{aligned}
 I_e &= \left(\frac{35.6}{60.5} \right)^3 8873 + \left[1 - \left(\frac{35.6}{60.5} \right)^3 \right] 5334 \\
 &= 6055 \text{ @ INT SPT}
 \end{aligned}$$

$$I_e = I_g = 8873 \text{ @ MIDSPAN}$$

$$\text{AVG } I_g = \frac{1}{2} (8873 + 6055) = 7464 \text{ in}^4$$

$$\Delta_i = \frac{1 \times (22 \times 12)^4}{185 \times 4030 \times 7464 \times 12} = 0.073"$$

$$\begin{aligned}
 (b) \quad M^- &= 169.4 \text{ 1-KIPS} \\
 M^+ &= 95.2 \text{ 1-KIPS}
 \end{aligned}
 \left. \begin{array}{l} \\ \end{array} \right\} \begin{array}{l} \text{TOTAL} \\ \text{DL +} \\ \text{LL} \end{array}$$

$$\begin{aligned}
 \text{AT EXT SPT } M_a &= 0, M_{cr} > M_a, I_e = I_g \\
 \text{AT MIDSPAN } M_a &= 95.2, M_{cr} < M_a, I_e < I_g \\
 \text{AT INT. SPT } M_a &= 169.4, M_{cr} < M_a, I_e < I_g
 \end{aligned}$$

$$I_{CT} = 5334 \text{ @ INT SPT (PART a)}$$

AT MIDSPAN

$$n A_s = 14.4 \text{ in}^2$$

$$K = 0.318, K_d = 6.20"$$

$$\begin{aligned}
 I_{CT} &= \frac{1}{3} \times 10 \times 6.20^3 + 14.4 \times 13.3^2 \\
 &= 3342 \text{ @ MIDSPAN}
 \end{aligned}$$

$$\begin{aligned}
 I_e &= \left(\frac{35.6}{95} \right)^3 8873 + \left[1 - \left(\frac{35.6}{95} \right)^3 \right] 3342 \\
 &= 3633 \text{ @ MIDSPAN}
 \end{aligned}$$

$$\begin{aligned}
 I_e &= \left(\frac{35.6}{169} \right)^3 8873 + [] 5334 \\
 &= 5368 \text{ @ INT. SUPPORT}
 \end{aligned}$$

$$\text{AVG } I_e = \frac{1}{2} (5368 + 3633) = 4501 \text{ in}^4$$

$$\Delta_{i, \text{sus}} = \frac{1.36 (22 \times 12)^4}{185 \times 4030 \times 4501 \times 12} = 0.16"$$

$$\Delta_{cr} = 2.0 \times 0.16 = 0.32"$$

$$(\Delta_i + \Delta_{cr})_{\text{sus}} = 0.48"$$

$$\begin{aligned}
 (c) \quad \Delta_{ST} &= \frac{(2.8 - 1.36) (22 \times 12)^4}{185 \times 4030 \times 4501 \times 12} \\
 &= 0.17"
 \end{aligned}$$

THE TOTAL DEFLECTION = 0.65". THIS EXCEEDS THE ACI 2/480 REQUIREMENT -

THE EARLY APPLICATION OF FULL LIVE LOAD INCREASED CRACKING + DECREASED THE STIFFNESS FOR ALL SUBSEQUENT LOADS

6.6 SAME BEAM AS PROBLEM 6.5

(a) SAME AS 6.5(b); $\Delta_i = 0.073''$ UNDER DL ONLY

(b) $W = w_d + 0.20w_e = 1.36 \text{ Kips/ft}$ $M^- = 82.3 \text{ kips}$
 $M^+ = 46.2 \text{ kips}$

MIDSPAN: $I_g = 8873 \text{ in}^4$ $I_{CT} = 3342$ $M_{cr} = 35.6 \text{ kips}$
 $I_e = \left(\frac{35.6}{46.2}\right)^3 8873 + \left[1 - \left(\frac{35.6}{46.2}\right)^3\right] 3342 = 5877 \text{ in}^4$

SUPPORT: $I_g = 8875 \text{ in}^4$ $I_{CT} = 5334$ $M_{cr} = 35.6 \text{ kips}$
 $I_e = \left(\frac{35.6}{82.3}\right)^3 8873 + \left[1 - \left(\frac{35.6}{82.3}\right)^3\right] 5334 = 5620 \text{ in}^4$

AVG. $I_e = \frac{1}{2} (5877 + 5620) = 5748$

$\Delta_{i,sus} = \frac{1.36 (22 \times 12)^4}{185 \times 4030 \times 5748 \times 12} = 0.113''$

$\Delta_{cr} = 2.0 \times 0.13 = 0.26''$

$(\Delta_i + \Delta_{cr})_{sus} = 0.39''$

(c) WITH FULL DL+LL IN PLACE, I_{AVG} IS THE SAME AS FOR PROBLEM 6.5b; $I_{AVG} = 4501$

THEN $\Delta_{i,DL+LL} = \frac{2.8 \times (22 \times 12)^4}{185 \times 4030 \times 4501 \times 12} = 0.34''$

AND FOR LAST 0.8xLL:

$\Delta_c = 0.13x_{LL} = \Delta_{i,DL+0.2LL} = 0.34 - 0.13 = 0.21''$

SO LATER APPLICATION OF FULL LL HAS

(1) REDUCED TOTAL DEFLECTION DUE TO SUSTAINED LOAD FROM 0.48'' TO 0.39''

(2) INCREASED DEFL. DUE TO SHORT-TERM PART OF LL FROM 0.17'' TO 0.21''

MAXIMUM DEFLECTION HAS DECREASED FROM 0.65'' TO 0.60''

7.1

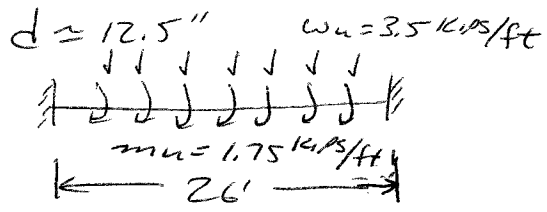
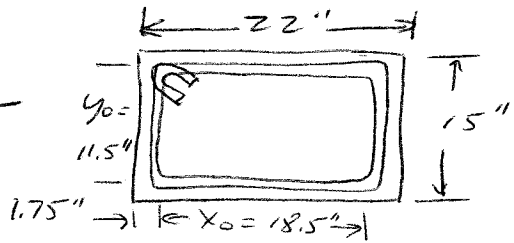

$V_u = 3.5 \times 13 = 45.5$ kips AT FACE OF SPT
 $= 3.5 \left(13 - \frac{12.5}{2}\right) = 41.85$ kips AT
 d FROM FACE OF SPT
 $T_u = 1.75 \times 13 = 22.75$ kips AT FACE
 OF SPT
 $= 2(11.96) = 20.9$ kips AT
 d FROM FACE OF SUPPORT

$A_{cp} = 22 \times 15 = 330$ in²
 $p_{cp} = 2(22 + 15) = 74$ in
 $\phi \times \sqrt{f_c} \frac{A_{cp}}{p_{cp}} = \frac{0.75 \times \sqrt{4000} \times 330}{12000 \times 74}$
 $= 5.81$ kips < T_u MUST DESIGN FOR TORSION

$b_w d = 22 \times 12.5 = 275$ in²
 $A_{oh} = 18.5 \times 11.5 = 213$ in²
 $p_h = 2(18.5 + 11.5) = 60$ in

$\sqrt{\left(\frac{41.85}{275}\right)^2 + \left(\frac{20.9 \times 12 \times 60}{1.7 \times 213}\right)^2} \leq \frac{0.75}{1900} (2\sqrt{4000} + 8\sqrt{4000})$

0.247 ≤ 0.474 OK

CHOOSE $\theta = 45^\circ$ - LOOK AT FACE OF SPT FOR REFERENCE

$A_t = \frac{T_u S}{2 \phi A_o f_y t \cot \theta} = \frac{22.75 \times 12.5}{2 \times 0.75 \times 181 \times 60 \times 1}$
 $= 0.01685$; $2A_t = 0.03365$

$\phi V_c = \frac{0.75 \times 2 \times \sqrt{4000} \times 275}{1000} = 26.1$ kips

$A_v = \frac{(45.5 - 26.1) S}{0.75 \times 60 \times 120.5} = 0.03455$

$V_u - \phi V_c = 0$ @ 7.46' FROM MIDSPAN
 $= 5.54'$ FROM FACE OF SPT

FOR $0 \leq x \leq 5.54'$ (x = DISTANCE FROM FACE OF SPT):

$2A_t + A_v = 0.03365 \left(1 - \frac{x}{13}\right) + 0.03455 \left(1 - \frac{x}{5.54}\right)$

FOR $5.54' \leq x \leq 13'$:
 $2A_t = 0.03365 \left(1 - \frac{x}{13}\right)$

TRAY No. 3	0.22 in ²	No. 4	0.45 in ²
No. 3		No. 4	
S _d	3.73"		6.79"
S ₂	4.35"		7.92"
S ₄	6.69"		12.2"

MAX SPACING $\frac{p_h}{8} = \frac{60}{8} = 7.5$ OR 12"

OR $d/2 = 12.5/2 = 6.25$ OR 24"

USE No. 4 CLOSED STIRRUPS W/ 1ST @ 3" FROM SPT. FACE, FOLLOWED BY 7 @ 6" - THEN USE 19 No. 3 STIRRUPS @ 6" TO MIDSPAN - [STIRRUPS MUST BE CONTINUED TO b + d = 34.5" = 2.9' FROM POINT WHERE $T_u = 5.8$ kips, WHICH OCCURS $\frac{5.8}{22.75} \times 13 = 3.31'$ FROM MIDSPAN - SO CONTINUE STIRRUPS THROUGHOUT THE SPAN.]

AL AT d FROM FACE OF SPT:

$\frac{A_t}{s} = 0.0168 \left(1 - \frac{1.04}{13}\right) = 0.0155$

$A_l = \frac{A_t p_h f_y t \times \cot^2 \theta}{s f_y}$
 $= 0.0155 \times 60 \times 1 \times 1 = 0.93$ in²

$A_{l, min} = \frac{5\sqrt{4000} \times 330}{60 \times 1000} - 0.0155 \times 60 \times 1 = 0.81$ in²

0.93 in² / 2 = 0.47 in² - ADD 0.47 in² TO TOP + BOTTOM FLEXURAL STEEL - TOTAL TOP + BOTTOM STEEL SHOULD CONSIST OF AT LEAST 3 EVENLY SPACED BARS TO ENSURE THAT SPACING IS < 12" NOTE: AL MAY BE REDUCED BY $\mu_u / (0.9d f_y)$ IN FLEXURAL COMPRESSION ZONES -

7.2

$$T_u = \frac{17.5 \times 2}{2} = 17.5 \text{ KIPS}$$

$$V_u = 17.5/2 = 8.75 \text{ KIPS}$$

$$M_{\text{STATIC}} = \frac{20 \times 20}{4} = 100 \text{ K}'$$

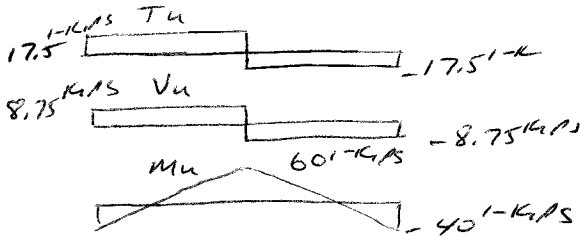

$$A_{CP} = 10 \times 20 = 20 \text{ in}^2$$

$$P_{CP} = 2(10 + 20) = 60 \text{ ''}$$

$$\phi \times \frac{F_c' A_{CP}}{P_{CP}} = \frac{0.75 \times 1 \sqrt{5000} \times 20}{12000 \times 60} = 2.95 \text{ KIPS} < T_u$$

MUST DESIGN FOR TORSION

$$b_w d = 10 \times 17 = 170 \text{ in}^2, x_o = 6.5, y_o = 16.5 \text{ ''}$$

$$A_o h = 6.5 \times 16.5 = 107 \text{ in}^2$$

$$A_o = 0.85 \times 107 = 91 \text{ in}^2$$

$$p_h = 2(6.5 + 16.5) = 46 \text{ ''}$$

$$\sqrt{\left(\frac{8.75}{170}\right)^2 + \left(\frac{17.5 \times 12 \times 46}{1.7 \times 107}\right)^2} \leq \frac{0.75}{1000} (10 \sqrt{5000})$$

$$0.497 \leq 0.530 \text{ OK}$$

CHOOSE $\theta = 45^\circ$

$$A_t = \frac{17.5 \times 12 \times 46}{2 \times 0.75 \times 91 \times 60} = 0.02565$$

$$\phi V_c = \frac{0.75 \times 2 \times 1 \sqrt{5000} \times 10 \times 17}{1000} = 18.63 \text{ K} > V_u$$

STIRRUPS REQUIRED FOR TORSION ONLY

$$2A_t = 0.05125$$

USE NO. 3 STIRRUPS THROUGHOUT

$$2A_t = 0.22, S = 0.22 / 0.0512 = 4.3 \text{ ''}$$

$$\text{MAX SPACING} = p_h / 8 = 46 / 8 = 5.7 \text{ ''} < 12 \text{ ''}$$

$$\text{OR } \frac{d}{2} = \frac{17}{2} = 8.5 \text{ '' OR } 24 \text{ ''}$$

USE $S = 4 \text{ ''}$, 1st STIRRUP 2 \text{ '' FROM SPT. FACE

$$A_t = \frac{A_t}{s} p_h \frac{f_y t \cot^2 \theta}{f_y} = 0.256 \times 46 \times 1 \times 1 = 1.18 \text{ in}^2$$

$$A_{t \text{ min}} = \frac{5 \sqrt{f_c'} A_{CP}}{f_y l} - \frac{A_t}{s} p_h \frac{f_y t}{f_y} = \frac{5 \sqrt{5000} \times 200}{60000} - 1.18 \approx 0 \text{ OK}$$

$$\frac{1.18}{3} = 0.39 \text{ in}^2 \rightarrow \text{ADD } 0.39 \text{ in}^2 \text{ TO TOP \& BOTTOM STEEL.}$$

ADD NO. 4 ($A_s = 0.20$) BARS AT MIDHEIGHT OF EACH SIDE

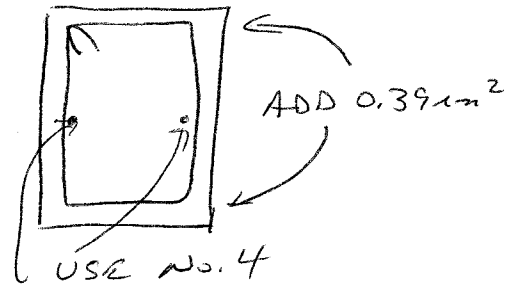

7.3 $w_u = 3.1 \text{ k/ft}$

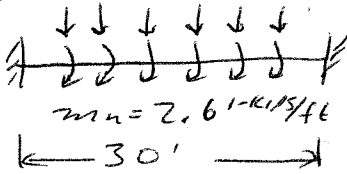

$V_u = 3.1 \times 15 = 46.5 \text{ kips}$ AT FACE OF SPT.
 $= 3.1 \left(15 - \frac{22.5}{2}\right) = 40.7$ AT d
 FROM FACE OF SPT.

$T_u = 2.6 \times 15 = 39 \text{ kips}$ AT FACE OF SPT.
 $= 2.6 \left(15 - \frac{22.5}{2}\right) = 34.1$ AT d
 FROM FACE OF SPT.

$A_{cp} = 14 \times 25 + 2 \times 5 \times 20 = 550 \text{ in}^2$
 $p_{cp} = 2(25 + 54) = 158 \text{ in}$
 $\phi \sqrt{f'_c} \frac{A_{cp}}{p_{cp}} = \frac{0.75 \times 1 \sqrt{4000} \times 550}{12000 \times 158} = 7.57 \text{ kips}$
 $< T_u \rightarrow$ MUST DESIGN FOR TORSION

$b_w d = 14 \times 22.5 = 315 \text{ in}^2$
 $x_0 = 14 - 3.5 = 10.5 \text{ in}$
 $y_0 = 25 - 3.5 = 21.5 \text{ in}$
 $A_{oh} = 10.5 \times 21.5 = 226 \text{ in}^2$
 $A_o = 0.85 \times 226 = 192 \text{ in}^2$
 $p_h = 2(10.5 + 21.5) = 64 \text{ in}^2$

$\sqrt{\left(\frac{40.7}{315}\right)^2 + \left(\frac{34.1 \times 12 \times 64}{1.7 \times 226^2}\right)^2} < \frac{0.75}{1000} (10 \sqrt{4000})$
 $0.328 \leq 0.474 \text{ OK}$

CHOOSE $\theta = 45^\circ$ - LOOK AT FACE OF SUPPORT FOR REFERENCE

$A_t = \frac{39 \times 12.5}{2 \times 0.75 \times 192 \times 60 \times 1} = 0.271 \text{ S}$

$Z A_t = 0.0542 \text{ S}$

$\phi V_c = \frac{0.75 \times 2 \times 1 \sqrt{4000} \times 315}{1000} = 29.9 \text{ kips}$

$A_u = \frac{(46.5 - 29.9) \text{ S}}{0.75 \times 60 \times 22.5} = 0.01645$

$V_u - \phi V_c = 0$ @ 9.65' FROM MIDSPAN = 5.35' FROM SPT FACE

$Z A_t + A_u = 0.0542 \text{ S} \left(1 - \frac{x}{15}\right) + 0.0164 \left(1 - \frac{x}{5.35}\right) \text{ FOR } 0 \leq x \leq 5.35', x = \text{DISTANCE FROM FACE OF SPT.}$

$Z A_t = 0.0542 \text{ S} \left(1 - \frac{x}{15}\right) \text{ FOR } 5.35' \leq x \leq 15'$

SELECT STRIAP SPACING + AL AS IN PROBLEM 7.1

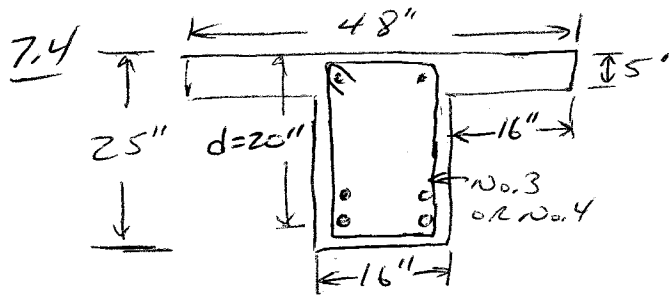

CHOOSE $\theta = 45^\circ$
 LOOK @ FACE OF SUPPORT
 FOR REFERENCE -

$$A_t = \frac{18 \times 125}{2 \times 0.75 \times 229 \times 60 \times 1} = 0.01055$$

Full wl: $w_u = 1.2 \times 0.93 + 1.6 \times 1.50 = 3.52 \text{ kips/ft}$

$$V_{u \max} = 3.52 \left(15 - \frac{20}{2}\right) = 46.9 \text{ kips @ FROM SPT FACE}$$

$$\text{VS. } \phi V_c = \frac{2 \times 0.75 \sqrt{6000} \times 16 \times 20}{1000} = 37.2 \text{ kips}$$

$$A_v = \frac{(46.9 - 37.2)5}{0.75 \times 60 \times 20} = 0.01085$$

COMPARE TO REQ. FOR TORSION

WE APPLIED TO 1/2 OF TOP SURFACE:

$$w_u = 1.2 \times 0.93 + 1.6 \times 0.75 = 2.32 \text{ kips/ft}$$

$$m_u = 1.6 \times 0.75 \times 1 = 1.2 \text{ kips/ft}$$

$$V_u = 2.32 \times 15 = 34.8 \text{ kips @ SPT FACE}$$

$$= 2.32 \left(15 - \frac{20}{2}\right) = 30.9 \text{ kips @ FROM SPT FACE}$$

$$T_u = 1.2 \times 15 = 18 \text{ kips @ SPT FACE}$$

$$= 1.2 \left(15 - \frac{20}{2}\right) = 16 \text{ kips @ FROM SPT FACE}$$

$$A_{cp} = 16 \times 25 + 2 \times 5 \times 16 = 560 \text{ in}^2$$

$$P_{cp} = 2(48 + 25) = 146$$

$$\phi \times \sqrt{f_c} \frac{A_{cp}^2}{P_{cp}} = \frac{0.75 \times 1 \sqrt{6000} \times 560^2}{12000 \times 146} = 13.91 \text{ kips} < T_u$$

DESIGN FOR TORSION

$$b_{wd} = 16 \times 20 = 320 \text{ in}^2$$

$$x_0 = 16 - 3.5 = 12.5$$

$$y_0 = 25 - 3.5 = 21.5$$

$$A_0h = 12.5 \times 21.5 = 269 \text{ in}^2$$

$$A_0 = 0.85 \times 269 = 229 \text{ in}^2$$

$$P_h = 2(12.5 + 21.5) = 68$$

$$\sqrt{\left(\frac{30.9}{320}\right)^2 + \left(\frac{16 \times 12 \times 68}{1.7 \times 229^2}\right)^2} \leq \frac{0.75}{1000} \times 10 \sqrt{6000}$$

$$0.175 \text{ ksi}$$

$$\leq 0.581 \text{ ksi OK}$$

$V_u < \phi V_c$, SO NO
 SHEAR STEEL NEEDED
 BASED ON STRENGTH -

BY INSPECTION,
 THIS CASE, NOT
 FULL WL, WILL GOVERN -

$$2A_t = 0.0210 \left(1 - \frac{x}{15}\right)$$

FROM SUPPORT TO MIDSPAN -

FINISH AS IN PROBLEM

7.1 -

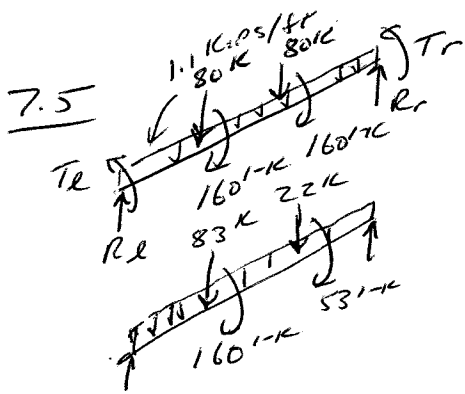

Case 1

Case 2

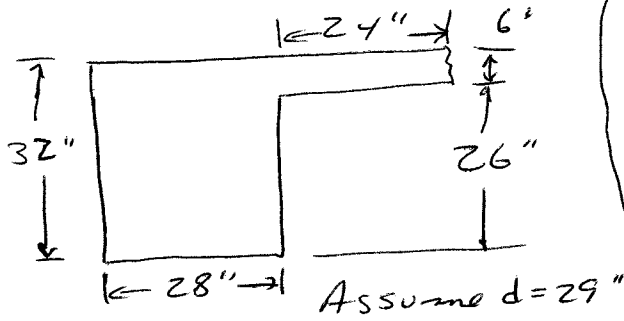

Case 1

$$R_l = R_r = 80 + 1.1 \times 18 = 99.8 \text{ kips}$$

$$T_l = T_r = 160 \text{ kips}$$

$$V_u @ d \text{ from face of support} = 99.8 - 1.1 \times \frac{29}{12} = 97.1 \text{ kips}$$

Case 2 (+3)

$$R_l = \frac{83 \times 24^2}{36^3} (3 \times 12 + 24) + \frac{22 \times 12^2}{36^3} (3 \times 24 + 12) + \frac{1.1 \times 36}{2} = 87 \text{ kips}$$

$$R_r = 83 + 22 + 1.1 \times 36 - 87 = 57.6 \text{ kips}$$

Torsion: 53 kips will be symmetrical. The balance (160 - 53 = 107 kips) will be split based on stiffness - 2/3 to left + 1/3 to right support -

$$T_l = 53 + \frac{2}{3} \times 107 = 124.3 \text{ kips}$$

$T_r = 88.7 \text{ kips}$. Case 3 is the mirror image -

Case 1 will control outer 1/3's of girder, Case 2 will control middle 12ft.

$$A_{cp} = 28 \times 32 + 24 \times 6 = 1040 \text{ in}^2$$

$$p_{cp} = 2 \times 32 + 2 \times 28 + 2 \times 24 = 168 \text{ in}$$

$$\phi \lambda \sqrt{f_c} \left(\frac{A_{cp}}{p_{cp}} \right) = 0.75 \times \sqrt{4800} \times \left(\frac{1040}{168} \right) = 305,400 \text{ in-kip} = 25.45 \text{ kips/ft}$$

∴ Must consider torsion

$$\phi 4 \lambda \sqrt{f_c} \left(\frac{A_{cp}}{p_{cp}} \right) = 101.8 \text{ kips/ft}$$

∴ Can design for this lower torque because structure is statically indeterminate - Max torque in middle 12' = 101.8 - 53 = 48.8 kips

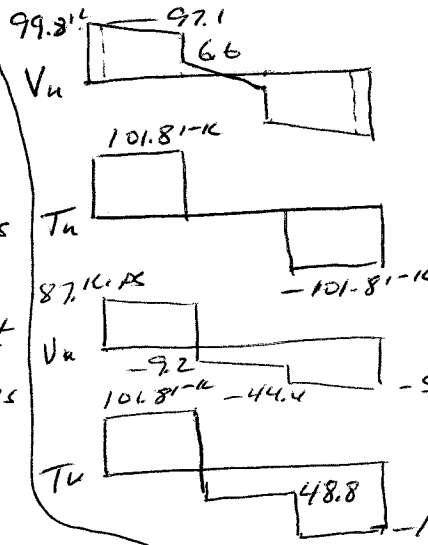

Case 1

Case 2 (assumed)

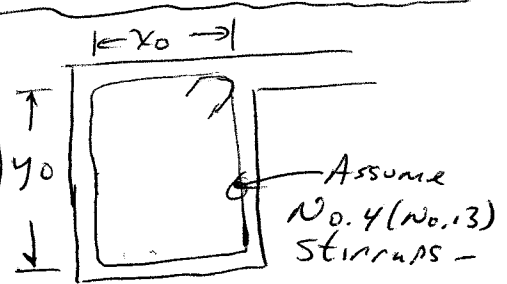

$$b_w d = 28 \times 29 = 812 \text{ in}^2$$

$$x_0 = 28 - 2 \times 1.5 - 0.5 = 24.5 \text{ in}$$

$$y_0 = 32 - 2 \times 1.5 - 0.5 = 28.5 \text{ in}$$

$$A_{oh} = 245 \times 28.5 = 698 \text{ in}^2$$

$$A_o = 0.85 A_{oh} = 593 \text{ in}^2$$

$$p_h = 106 \text{ in}$$

7.5 continued

$$\sqrt{\left(\frac{97.1 \times 1000}{812}\right)^2 + \left(\frac{101.8 \times 12000 \times 106}{1.7 \times 698^2}\right)^2}$$

$$\leq \frac{0.75}{1000} (2\sqrt{4000} + 8\sqrt{4000})$$

193 psi \leq 474 psi OK

Choose $\theta = 45^\circ$

$$A_t = \frac{T_u s}{2\phi A_o f_y t \cot\theta} = \frac{101.8 \times 12.5}{2 \times 0.75 \times 593 \times 60 \times 1}$$

$$= 0.02295$$

$$V_c = \frac{2\sqrt{4000} \times 28 \times 29}{1000} = 102.7 \text{ KIPS}$$

$$A_v = \left(\frac{97.1}{0.75} - 102.7\right) s / (60 \times 29) = 0.01545$$

$$(2A_t + A_v) = 2 \times 0.02295 + 0.01545 = 0.06125$$

Using No. 4 (No. 13) bars, $A_{zless} = 0.4 \text{ in}^2$

$$s = \frac{0.4}{0.0612} = 6.54 \text{ in.}, \text{ say } 6\frac{1}{2} \text{ in.}$$

$$s_{\text{max torsion}} = p_h/8 = 106/8 = 13.25 < 12''$$

$$s_{\text{max shear}} = d/2 = 14.5'' < 24''$$

$$\text{min steel} = \frac{A_{vmin} f_y t}{50 b_w} = \frac{0.4 \times 60000}{50 \times 28} = 17.4 \text{ in}$$

$$\leq \frac{A_{vmin} f_y t}{0.75 \sqrt{f_c} b_w} = \frac{0.4 \times 60000}{0.75 \sqrt{4000} \times 28} = 18.1 \text{ in.}$$

Can switch to No. 5 (No. 16) bars

$$\rightarrow A_{zless} = 0.62 \text{ in}^2$$

$$s = \frac{0.62}{0.0612} = 10.13 \text{ in} \rightarrow \text{use } 10 \text{ in.}$$

For middle 1/3 of beam, $A_v = 0$

$$A_t = 0.0229 \frac{48.8}{101.8} = 0.01105$$

$$2A_t = 0.02205$$

Using No 4 (No. 13) bars

$$s = \frac{0.4}{0.02205} = 18 \text{ in}$$

Use No. 4 @ 12 in.

Because $V \approx$ constant in outer 1/3 of beam, use constant spacing in each section

$$\frac{A_t}{s} = 0.0229 \quad \rightarrow = 1$$

$$A_{L} = \frac{A_t}{s} p_h \left(\frac{f_y t}{A_y}\right) \cot^2 \theta$$

$$= 0.0229 \times 106 = 2.43 \text{ in}^2$$

$$A_{Lmin} = \frac{5\sqrt{f_c} A_{cp} - A_t p_h \frac{f_y t}{f_y}}{f_y} \quad \rightarrow = 1$$

$$= \frac{5\sqrt{4000} \times 1040 - 0.0229 \times 106}{60000}$$

$$= 3.05 \text{ in}^2$$

$$\rightarrow \text{use } \frac{3.05}{10} = 0.305 \text{ in}^2$$

for each of 10 longitudinal bar locations

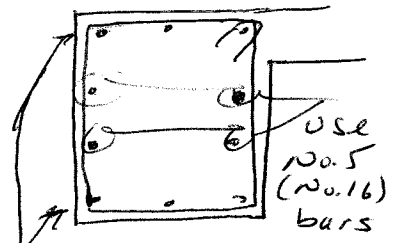

$$\text{add } 3 \times 0.305 = 0.92 \text{ in}^2$$

to top + bottom flexural steel -

All steel must be anchored -

∴ longitudinal steel ≥ 0.0425

$$= 0.5 \text{ in.}$$

No. 5 bars OK -

5.6

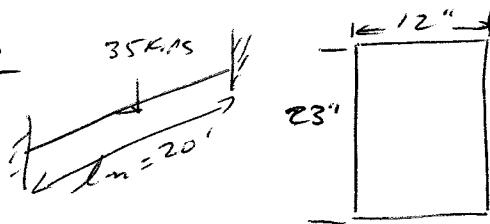

$$d = 20'' \quad w_d = \frac{12 \times 23}{144} \times 0.15 = 0.288 \text{ kips/ft}$$

$V_u + T_u$ @ d from face of spt.

$$V_{u \max} = 1.2 \times 0.288 \left(\frac{20}{2} - \frac{20}{12} \right) + 1.6 \frac{35}{2} = 30.88 \text{ kips}$$

$$T_{u \max} = 1.6 \times 35 \text{ kips} / 2 = 28 \text{ kips}$$

$$A_{cp} = 12 \times 23 = 276 \text{ in}^2$$

$$p_{cp} = 2(23 + 12) = 70 \text{ in.}$$

$$\phi \sqrt{f'_c} \left(\frac{A_{cp}}{p_{cp}} \right)^2 = 0.75 \times \sqrt{4000} \left(\frac{276}{70} \right)^2 = 51,619 \text{ in}^2 = 4.3 \text{ kips} < T_{u \max}$$

\therefore must consider torsion

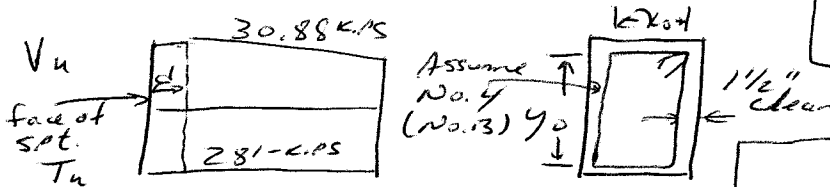

span

$$b_w d = 12 \times 20 = 240 \text{ in}^2$$

$$x_0 = 12 - 2 \times 1/2 - 1/2 = 8.5 \text{ in.}$$

$$y_0 = 23 - 2 \times 1/2 - 1/2 = 19.5 \text{ in.}$$

$$A_{oh} = 8.5 \times 19.5 = 165.8 \text{ in}^2$$

$$A_o = 0.85 A_{oh} = 141 \text{ in}^2$$

$$p_h = 2(x_0 + y_0) = 56 \text{ in.}$$

$$\sqrt{\left(\frac{V_u}{b_w d} \right)^2 + \left(\frac{T_u p_h}{1.7 A_{oh}^2} \right)^2} \leq \phi \left(\frac{V_c}{b_w d} + 8 \sqrt{f'_c} \right)$$

$$\sqrt{\left(\frac{30.88 \times 1000}{240} \right)^2 + \left(\frac{28 \times 2000 \times 56}{1.7 \times 165.8^2} \right)^2} \leq 0.75 \times 10 \sqrt{4000}$$

$$422 \leq 474 \checkmark \text{ section is OK}$$

$$A_t = \frac{T_u s}{2 \phi A_o f_{yt} \cot \theta} \quad \text{Use } \theta = 45^\circ$$

$$A_t = \frac{28.04 \times 12.5}{2 \times 0.75 \times 141 \times 60 \times 1} = 0.2655$$

$$V_c = \frac{2 \sqrt{4000} \times 12 \times 20}{1000} = 30.3614 \text{ kips}$$

$$A_v = \frac{(V_u - V_c) s}{f_{yt} d} = \frac{\left(\frac{30.88}{0.75} - 30.36 \right) s}{60 \times 20} = 0.0095$$

$$2A_t + A_v = 2 \times 0.2655 + 0.0095 = 0.06205$$

Using No. 4 (No. 13) bars,

$$A_{z \text{ legs}} = 0.40$$

$$s = \frac{0.40}{0.620} = 6.45 \text{ in.}$$

$$s_{\max \text{ torsion}} = p_h / 8 = 56 / 8 = 7 \text{ in.} < 12 \text{ in.}$$

$$s_{\max \text{ shear}} = d / 2 = 10 \text{ in.} < 24 \text{ in.}$$

$$\text{main steels} \leq \frac{A_{min} f_{yt}}{50 \text{ bw}} = \frac{0.40 \times 60000}{50 \times 12} = 40.0 \text{ in.}$$

$$\leq \frac{A_{min} f_{yt}}{\phi \sqrt{f'_c} \text{ bw}} = 42 \text{ in.}$$

Since T_u is constant + V_u is nearly constant throughout, place 1st stirrup @ 3" from face of support + use $s = 6"$ throughout the beam -

5.6 continued

$$A_t/s = 0.02655$$

$$A_L = \frac{A_t}{s} \rho_n \left(\frac{f_{yt}}{f_y} \right) \cot^2 \theta$$

$$= 0.0265 \times 56 \times 1 \times 1 = 1.48 \text{ in}^2$$

$$A_{Lmin} = \frac{5\sqrt{f_c}}{f_y} - \frac{A_t \rho_n}{s} \frac{f_{yt}}{f_y} \quad \frac{A_t}{s} \geq \frac{25b_w}{f_{yt}} = 0.005 \checkmark$$

$$= \frac{5\sqrt{4900 \times 276}}{60,000} - 0.0265 \times 56 \times 1 = -0.03 \text{ in}^2$$

use $1.48/6 = 0.247 \text{ in}^2$ for each of 6

longitudinal bar locations* — $d_g \geq 0.042 \times s = 0.25$

use No. 5's (No. 16's) for isolated bars

For flexural tension zones, increase $A_s + A_s'$

by $2 \times 0.247 \text{ in}^2$ — All steel must be anchored

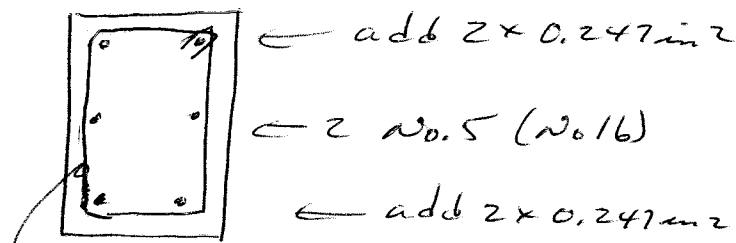

Use No. 4 (No. 13)
bars @ 6 in.

* max spacing $\leq \rho_n l_8$ or 12 in

8.1

BALANCE POINT

$$C_b = \frac{0.003}{6.0/29 \times 10^3 + 0.003} \times 13 = 7.69''$$

$$a_b = 0.80 \times 7.69 = 6.15''$$

$$E_{s1}' = 0.003(7.69-3)/7.69 = 0.00183; f_s' = 53.06 \text{ ksi}$$

$$P_b = 0.85 \times 5 \times 6.15 \times 16 + 4.5(53.06 - 0.85 \times 5) \times 5 - 4.5 \times 60 = 368 \text{ kips}$$

$$M_b = 0.85 \times 5 \times 6.15 \times 16 \left(8 - \frac{6.15}{2}\right) + 4.5(53.06 - 0.85 \times 5) \times 5 + 4.5 \times 60 \times 5 = 4508''\text{-k} = 376' \text{-k}$$

$$P_o = 0.85 \times 5(16^2 - 9) + 9 \times 60 = 1590 \text{ kips}$$

M_o: FROM ITERATIONS C = 3.73

$$a = 2.98$$

$$E_{s1}' = 0.00054 \rightarrow f_s' = 17.11 \text{ ksi}$$

$$E_{s2}' = 0.00746 \rightarrow f_s = 60 \text{ ksi}$$

$$P = 0$$

$$M_o = 0.85 \times 5 \times 2.98 \times 16 \left(8 - \frac{2.98}{2}\right) + 4.5(17.11 - 0.85 \times 5) \times 5 + 4.5 \times 60 \times 5 = 2959''\text{-k} = 247' \text{-k}$$

SMALLER C → TRY C = 5.6" ①

$$a = 4.48''$$

$$E_{s1}' = 0.00139 \quad f_s' = 40.3 \text{ ksi}$$

$$E_{s2}' = 0.00396 \quad f_s = 60 \text{ ksi}$$

$$P_m = 0.85 \times 5 \times 4.48 \times 16 + 4.5(40.3 - 0.85 \times 5) \times 5 - 4.5 \times 60 = 197 \text{ kips}$$

$$M_m = 0.85 \times 5 \times 4.48 \times 16 \left(8 - \frac{4.48}{2}\right) + 4.5(40.3 - 0.85 \times 5) \times 5 + 4.5 \times 60 \times 5 = 3916''\text{-kips} = 326' \text{-kips}$$

LARGER C → TRY C = 14.4" ②

$$a = 11.52''$$

$$E_{s1}' = 0.00238 \quad f_s' = 60 \text{ ksi}$$

$$E_{s2}' = 0.00029 \quad f_s = 8.4 \text{ ksi} \text{ COMPRESSION}$$

$$P_m = 0.85 \times 5 \times 11.52 \times 16 + 4.5(60 - 0.85 \times 5) \times 5 + 4.5(8.4 - 0.85 \times 5) \times 5 = 1053 \text{ kips}$$

$$M_m = 0.85 \times 5 \times 11.52 \times 16 \left(8 - \frac{11.52}{2}\right) + 4.5(60 - 0.85 \times 5) \times 5 - 4.5(8.4 - 0.85 \times 5) \times 5 = 2916''\text{-k} = 243' \text{-k}$$

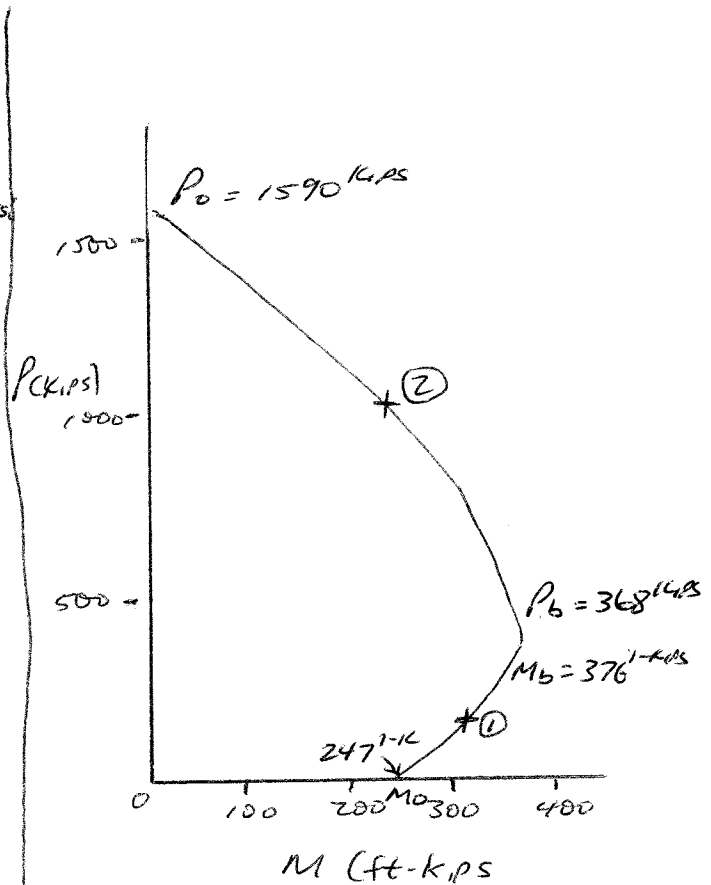

8.2

$$P_o = 0.85 \times 8(16^2 - 9) + 9 \times 60 \\ = 2220 \text{ kips}$$

Compared to problem 8.1, this represents $\frac{2220 - 1590}{1590} \times 100 = 39.6\%$ greater axial load capacity -

Using point 1 from Problem 8.1, $c = 5.6 \text{ in}$, $a = 3.64 \text{ in}$, $f_s + f_s'$ are as shown in Problem 8.1 -

$$P_m = 0.85 \times 8 \times 3.64 \times 16 \\ + 4.5(40.3 - 0.85 \times 8) - 4.5 \times 60 = 277 \text{ kips}$$
$$\frac{277 - 197}{197} \times 100 = 40\% \text{ increase}$$

$$M_m = 0.85 \times 8 \times 3.64 \times 16 \left(8 - \frac{3.64}{2}\right) \\ + 4.5(40.3 - 0.85 \times 8) \times 5 + 4.5 \times 60 \times 5 \\ = 4049 \text{ in-kips} = 337 \text{ ft-kips}$$
$$\frac{337 - 326}{326} \times 100 = 3.4\%$$

f'_c is not recommended for higher floors because increase in flexural capacity is minimal. $f'_c = 8000 \text{ psi}$ is justified only where higher axial load capacity is needed.

8.3

$$P_0 = 1590 \text{ KIPS}$$

$$\phi P_0 = 0.65 \times 1590 = 1034 \text{ KIPS}$$

$$\alpha \phi P = 0.8 \times 0.65 \times 1590 = 827 \text{ KIPS}$$

$$M_0 = 2471 \text{ ft-KIPS}$$

$$\phi M_0 = 0.9 \times 2471 = 2224 \text{ ft-KIPS}$$

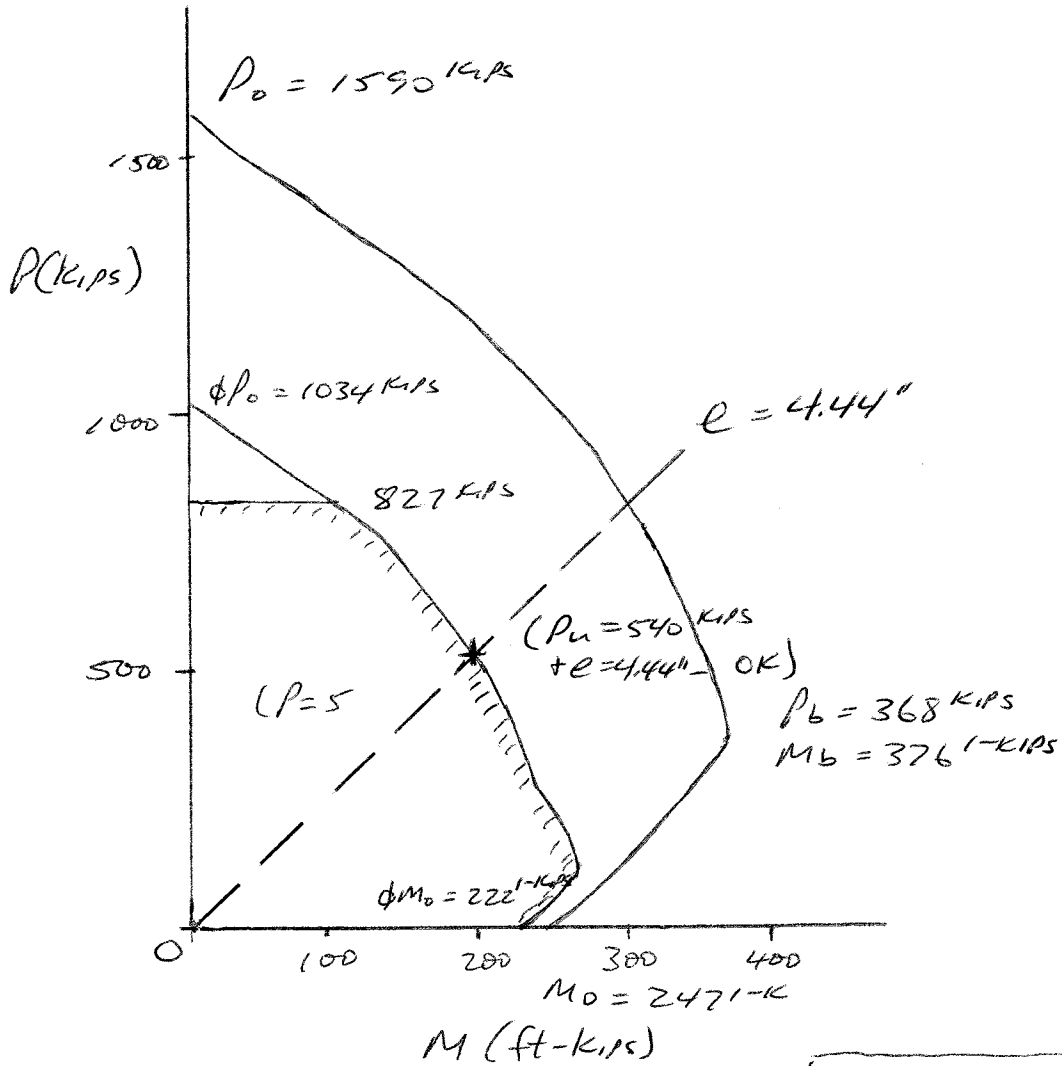

ASSUME NO. 4 BARS FOR TIES

$$S_{MAX} \leq 16 \times 1.693 = 27"$$

$$48 \times 0.5 = 24"$$

16" CONTROLS

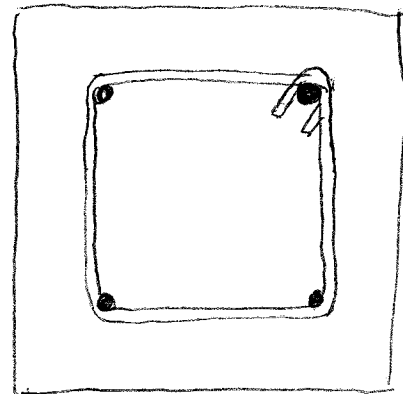

8.4 $\rho = 0.0254$

(a) BALANCED POINT

$$c_b = \frac{e_u}{e_y + e_u} d = \frac{0.003}{0.00207 + 0.003} \times 17 = 10.06''$$

$$a_b = 0.85 \times c_b = 8.55''$$

$$E_s' = 0.003 \frac{10.06 - 3}{10.06} = 0.0021$$

$$f_s' = 60 \text{ ksi}$$

$$P_b = 0.85 \times 4 \times 8.55 \times 15 + 3.81 (60 - 0.85 \times 4) - 3.81 \times 60 = 423 \text{ KIPS}$$

$$M_b = 0.85 \times 4 \times 8.55 \times 15 \left(10 - \frac{8.55}{2}\right) + 3.81 (60 - 0.85 \times 4) \times 7 + 3.81 \times 60 \times 7 = 5606 \text{ in-kips} = 476 \text{ ft-kips}$$

$$P_o = 0.85 \times 4 \times (15 \times 20 - 7.62) + 60 \times 7.62 = 1451 \text{ KIPS}$$

M_o : AFTER ITERATION $c = 3.75''$

$$a = 3.19''$$

$$E_s' = 0.0006 \rightarrow f_s' = 17.4 \text{ ksi}$$

$$E_s = 0.0106 \rightarrow f_s = 60 \text{ ksi}$$

$$M_o = 0.85 \times 4 \times 3.19 \times 12 \left(10 - \frac{3.19}{2}\right) + 3.81 (29.67 - 0.85 \times 4) \times 7 + 3.81 \times 60 \times 7 = 3341 \text{ in-k} = 278 \text{ ft-k}$$

$$c = 7'' < c_b \quad (1)$$

$$a = 0.85 \times 7 = 5.95''$$

$$E_s' = 0.003 (7 - 3) / 7 = 0.0017 \rightarrow f_s' = 49.3 \text{ ksi}$$

$$f_s = 60 \text{ ksi}$$

$$P_m = 0.85 \times 4 \times 5.95 \times 15 + 3.81 (49.3 - 0.85 \times 4) - 3.81 \times 60 = 250 \text{ KIPS}$$

$$M_m = 0.85 \times 4 \times 5.95 \times 15 \left(10 - \frac{5.95}{2}\right) + 3.81 (49.3 - 0.85 \times 4) \times 7 + 3.81 \times 60 \times 7 = 4956 \text{ in-kips} = 413 \text{ ft-kips}$$

$$c = 15'' > c_b \quad (2)$$

$$a = 12.75''$$

$$E_s' = 0.0024 \rightarrow f_s' = 60 \text{ ksi}$$

$$E_s = 0.0004 \rightarrow f_s = 11.6 \text{ ksi}$$

$$P_m = 0.85 \times 4 \times 12.75 \times 15 + 3.81 (60 - 0.85 \times 4) - 3.81 \times 11.6 = 822 \text{ KIPS}$$

$$M_m = 0.85 \times 4 \times 12.75 \times 15 \left(10 - \frac{12.75}{2}\right) + 3.81 (60 - 0.85 \times 4) \times 7 + 3.81 \times 11.6 \times 7 = 4176 \text{ in-kips} = 348 \text{ ft-kips}$$

(b) From GRAPH A.10, $\rho = 0.0254$

$$P_b = 0.35 \times 4 \times 300 = 420 \text{ KIPS}$$

$$M_b = 0.231 \times 4 \times 300 \times 20 = 5544 \text{ in-kips} = 462 \text{ ft-kips}$$

$$P_o = 1.2 \times 4 \times 300 = 1440 \text{ KIPS}$$

$$M_o = 0.145 \times 4 \times 300 \times 20 = 3480 \text{ in-kips} = 290 \text{ ft-kips}$$

$$(1) \frac{\rho}{h} = \frac{4956}{250 \times 20} = 0.99$$

$$\text{FOR } \frac{\rho}{h} = 0.99 \text{ AND } \rho = 0.0254$$

$$P_m = 0.215 \times 4 \times 300 = 258 \text{ KIPS}$$

$$M_m = 0.21 \times 4 \times 300 \times 20 = 5040 \text{ in-kips} = 420 \text{ ft-kips}$$

$$(2) \frac{\rho}{h} = \frac{4176}{822 \times 20} = 0.254$$

$$\text{FOR } \frac{\rho}{h} = 0.254 \text{ AND } \rho = 0.0254$$

$$P_m = 0.68 \times 4 \times 300 = 816 \text{ KIPS}$$

$$M_m = 0.175 \times 4 \times 300 \times 20 = 4200 \text{ in-kips} = 350 \text{ ft-kips}$$

(c) - SEE NEXT PAGE

(d) MINIMUM NO. 3 BARS

$$S_{MAX} \leq 16 \times 1.27 = 20.3''$$

$$48 \times 0.375 = 18''$$

$$15'' \text{ CONTROLS}$$

8.4 continued

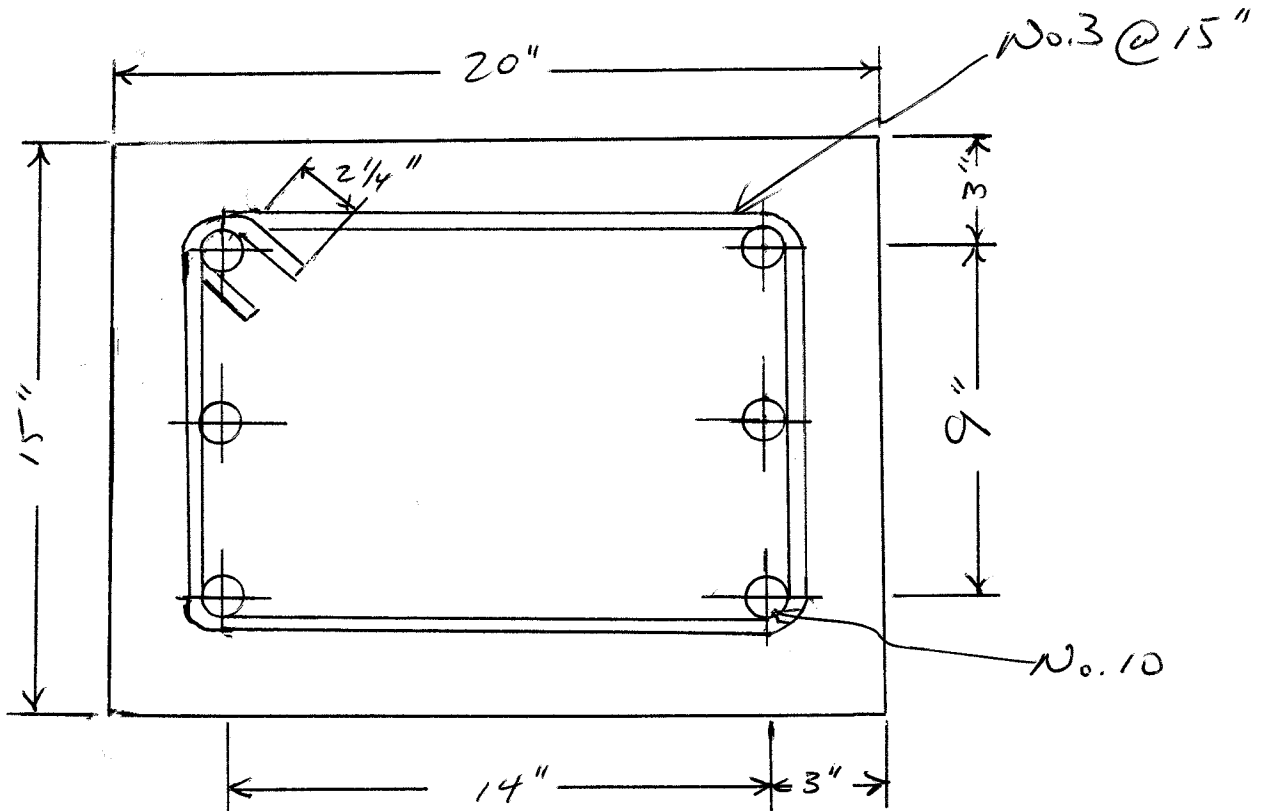
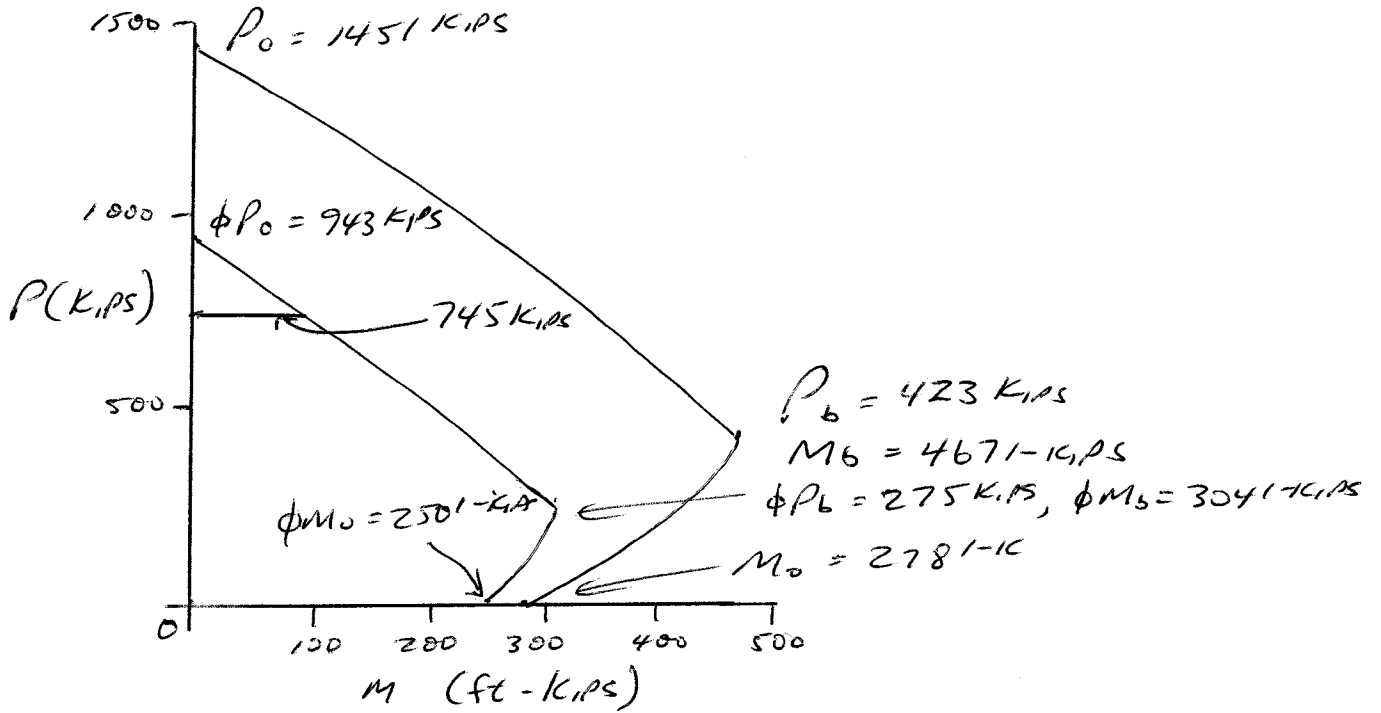

8.5

$$e_g = \frac{15.24}{625} = 0.244$$

$$j = \frac{20}{25} = 0.8$$

Using Graph A.7

$$k_m = \frac{1250}{4 \times 625} = 0.50$$

$$R_m = 0.1875$$

$$\begin{aligned} M_m &= 0.1875 \times 4 \times 625 \times 25 = 11,719 \text{ in-kips} \\ &= 977 \text{ ft-kips} \end{aligned}$$

8.6

From Graph A.7

$$P_m = 0, K_m = 0$$

$$R_m = 0.2475$$

$$\begin{aligned} M_m &= 0.2475 \times 4 \times 625 \times 25 = 15469 \text{ in.-kips} \\ &= 1289 \text{ ft-kips} \end{aligned}$$

8.7 COLUMN INTERACTION DIAGRAM

AXIAL THRUST CONDITION.

DUE TO LARGE AMOUNT OF LONGITUDINAL REINFORCEMENT;

$$P_o = .85f'_c (A_g - A_s) + A_s f_y = 5277 \text{ KIPS}$$

BALANCED CONDITION.

$$C_b = \frac{0.0025}{0.002 + 0.0025} \times 27.0 = 16.2$$

$$a = \beta_1 C = .65 \times 16.2 = 10.53 \text{ IN.}$$

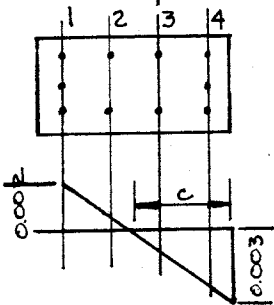

$$E_1 = 0.0020$$

$$E_2 = 0.0005 \Rightarrow f_{s2} = 14500 \text{ PSI}$$

$$E_3 = 0.0009 \Rightarrow f_{s3} = 26100 \text{ PSI}$$

$$E_4 = 0.0024$$

$$\text{AND } f_{s1} = f_{s4} \text{ CANCEL.}$$

$$P_b = 0.85f'_c a_b b + E_3 E_s A_{s3} + E_2 E_s A_{s2} = 0.85 \times 8 \times 10.53 \times 20 + 261 \times 4.5 - 14.5 \times 4.5$$

$$P_b = 1484 \text{ KIPS.}$$

$$P_b e' = 0.85f'_c a b \left(4 - \frac{a}{2}\right) + E_3 E_s A_{s3} (16) + E_y E_s A_{s4} (24) - E_2 E_s A_{s2} (8) = 3517$$

$$e' = 2.37 \text{ FT} = 28.44 \text{ IN.}$$

$$e_b = e' - 12 \text{ IN} = 16.44 \text{ IN.}$$

$$M_b = 1484 \text{ K} \times \frac{16.44}{12} = 2033 \text{ KIP-FT}$$

OTHER POINTS

C	E_1/f_s	E_2/f_s	E_3/f_s	E_4/f_s
27"	0.0000	0.0009	0.0018	0.0026
$\rightarrow f_s$	0	26100	52200	60000
19"	0.0013	0.0000	0.0013	0.0025
$\rightarrow f_s$	37700	0	37700	60000
11"	0.0044	0.0022	0.0000	0.0022
$\rightarrow f_s$	60000	60000	0	60000
3"	0.0240	0.0160	0.0080	0.0000
$\rightarrow f_s$	60000	60000	60000	0

$$\text{FOR } C = 27.0 \text{ IN. } a = 17.55 \text{ IN.}$$

$$P_n = 0.85f'_c ab + \sum f_s A_s$$

$$= .85 \times 8 \times 17.55 \times 20 + 26.1 \times 4.5 + 52.2 \times 4.5 + 60 \times 6.75 = 3,144 \text{ KIPS.}$$

$$M_n = .85f'_c ab \left(\frac{h}{2} - \frac{a}{2}\right) + \sum f_s A_s z$$

$$= 2386 \times 6.225 - 26.1 \times 4.5 \times 4 + 52.2 \times 4.5 \times 4 + 60 \times 6.75 \times 12 = 1349 \text{ KIP-FT.}$$

$$\text{FOR } C = 19.0 \text{ IN. } a = 12.35 \text{ IN.}$$

$$P_n = 2000 \text{ KIPS } M_n = 1951 \text{ KIP-FT.}$$

$$\text{FOR } C = 11.0 \text{ IN. } a = 7.15 \text{ IN.}$$

$$P_n = 702 \text{ KIPS } M_n = 1825 \text{ FT-KIPS}$$

$$\text{FOR } C = 3 \text{ IN. } a = 1.95 \text{ IN.}$$

$$P_n = -680 \text{ KIPS } M_n = 715 \text{ FT-KIPS}$$

NOT VALID, BUT CAN BE USED TO CONSTRUCT DIAGRAM.

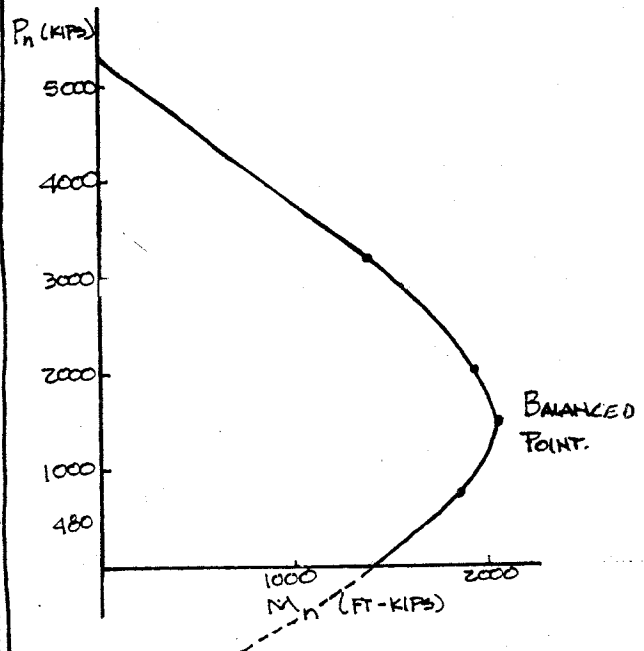

8.8

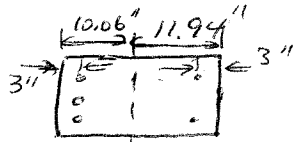

PLASTIC CENTROID

$$\bar{x} = \frac{0.85 \times 6 \times 14 \times 22^2 / 2 + 6.75 \times 75 \times 19 + 3.12 \times 75 \times 3}{0.85 \times 6 \times 14 \times 22 + 6.75 \times 75 + 3.12 \times 75} = 11.94''$$

$$P_0 = 0.85 \times 6 \times 14 \times 22 + (75 - 0.85 \times 6) (3.12 + 6.75) = 2261 \text{ kips}$$

$$e' = 3.12 / (14 \times 19) = 0.0117$$

$$e = 6.75 / (14 \times 19) = 0.0254$$

$$e + c = 0.85 \times 0.75 \times \frac{6}{75} \times \frac{0.003}{0.003 + 75/29000} = 0.0274 > e$$

∴ CONSIDER AS SIMPLY REINFORCED

$$a = \frac{6.75 \times 75}{0.85 \times 6 \times 14} = 7.09''$$

$$M_0 = 6.75 \times 75 (19 - 7.09/2) = 7824 \text{ in-kips} = 652 \text{ ft-kips}$$

BALANCED CONDITION

$$\frac{c}{0.203} = \frac{19}{0.003 + 75/29000} \rightarrow c = 10.2'', a = 7.65''$$

$$E_s' = \frac{7.2}{70.2} \times 0.003 = 0.00212 \rightarrow f_s' = 61.48 \text{ ksi}$$

$$P_b = 0.85 \times 6 \times 14 \times 7.65 + 3.12 (61.48 - 0.85 \times 6) - 6.75 \times 75 = 215 \text{ kips}$$

$$M_b = 0.85 \times 6 \times 14 \times 7.65 (11.94 - 7.65/2) + 3.12 (61.48 - 5.1) \times 8.94 + 6.75 \times 75 \times 7.06 = 9579 \text{ in-kips} = 798 \text{ ft-kips}$$

TRANSVERSE FAILURE IN STEEL

Mm BETWEEN Mb + Mo

TRY c = 9.8" → a = 7.35"

$$E_s' = \frac{6.8}{9.8} \times 0.003 = 0.00208 \rightarrow f_s' = 60.37 \text{ ksi}$$

$$P_m = 0.85 \times 6 \times 14 \times 7.35 + 3.12 (60.37 - 5.1) - 6.75 \times 75 = 191 \text{ kips}$$

$$M_m = 0.85 \times 6 \times 14 \times 7.35 (11.94 - 7.35/2) + 3.12 (60.37 - 5.1) \times 8.94 + 6.75 \times 75 \times 7.06 = 9443 \text{ in-kips} = 787 \text{ ft-kips}$$

COMPRESSION FAILURE IN CONCRETE

TRY a = 12" → c = 16"

$$E_s' = \frac{13}{16} \times 0.003 = 0.00244 \rightarrow f_s' = 70.69 \text{ ksi}$$

$$E_s = \frac{3}{16} \times 0.003 = 0.00056 \rightarrow f_s = 16.24 \text{ ksi}$$

$$P_m = 0.85 \times 6 \times 14 \times 12 + 3.12 (70.69 - 5.1) - 6.75 \times 16.24 = 953 \text{ kips}$$

$$M_m = 0.85 \times 6 \times 14 \times 12 (11.94 - 6) + 3.12 (70.69 - 5.1) \times 8.94 + 6.75 \times 16.24 \times 7.06 = 7700 \text{ in-kips} = 642 \text{ ft-kips}$$

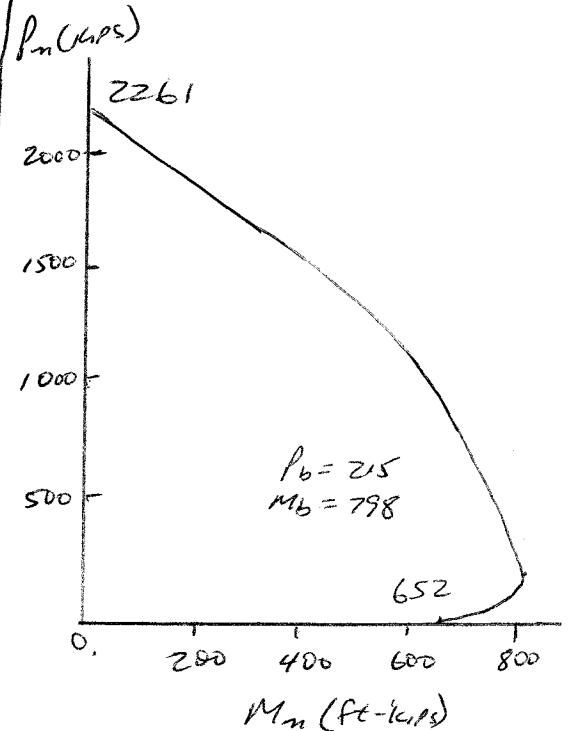

8.9

(a) $P_u = 130 \text{ KIPS}$, $e/h = \frac{2.7}{10} = 0.27$

$\gamma = \frac{6}{10} = 0.60$ USE GRAPH A.9

$K_m = \frac{P_u}{\phi f_c A_g} = \frac{130}{0.65 \times 4 \times 100} = 0.50$

FROM GRAPH A.9, $\rho_g = 0.01$

$A_{st} = 1 \text{ in}^2$, USE 4 NO. 5 BARS

$A_{st} = 4 \times 0.31 = 1.24 \text{ in}^2$

TRANSVERSE REINFORCEMENT
USE NO. 3 BARS

$S_{max} \leq 16 \times 0.625 = 10" \leftarrow$

$\leq 48 \times 0.375 = 18" \leftarrow$

$\leq 10" \leftarrow$

(b) USE RECIPROCAL LOAD METHOD

$P_n \geq \frac{P_u}{\phi} = 200 \text{ KIPS}$

$e/h_x = e/h_y = 0.27$

TRY 4 NO. 9 BARS, $A_{st} = 4.00 \text{ in}^2$

$\rho_g = 0.04$, USE GRAPH A.9

$P_{nx} = P_{ny} = 0.745 \times 4 \times 100 = 298 \text{ KIPS}$

$P_o = 1.415 \times 4 \times 100 = 566 \text{ KIPS}$

$\frac{1}{P_n} = \frac{1}{P_{nx}} + \frac{1}{P_{ny}} - \frac{1}{P_o}$

$P_n = 202 \text{ KIPS OK}$

(c)

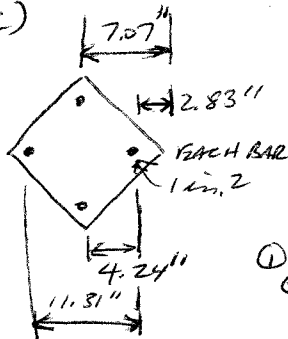

BALANCED POINT

$C_b = \frac{0.003}{69/29000 + 0.003} \times 11.31$

$= 6.69"$

$a = 0.85 \times 6.69 = 5.69"$

① $\epsilon_{s1} = \frac{6.69 - 2.83}{6.69} \times 0.003$

$= 0.00173$

$f_{s1} = 50.2 \text{ KSI}$

② $\epsilon_{s2} = \frac{7.07 - 6.69}{6.69} \times 0.003 = 0.00017$

$f_{s2} = 4.94 \text{ KSI}$

③ $f_{s3} = 60 \text{ KSI}$

$P_b = 0.85 \times 4 \times 5.69^2 + (50.2 - 0.85 \times 4) \times 1$
 $- 4.94 \times 2 - 60 \times 1$
 $= 87 \text{ KIPS}$

$M_b = 0.85 \times 4 \times 5.69^2 \left(7.07 - \frac{2}{3} \times 5.69\right)$
 $+ (50.2 - 3.4) \times 1 \times 4.24$
 $+ 60 \times 1 \times 4.24 = 813 \text{ in-KIPS} = 68 \text{ ft-KIPS}$

$P_o = 0.85 \times 4 \times 100 + 4(60 - 3.4) = 566 \text{ KIPS}$

M_o : AFTER SOME ITERATION

$C = 5.45$, $a_c = 0.85 \times 5.45 = 4.63"$

$\epsilon_{s1} = \frac{5.45 - 2.83}{5.45} \times 0.003 = 0.00144$

$f_{s1} = 41.8 \text{ KSI}$

$f_{s3} = 60 \text{ KSI}$

$M_b = 0.85 \times 4.63^2 \left(7.07 - \frac{2}{3} \times 4.63\right)$

$+ (41.8 - 3.4) \times 1 \times 4.24$

$+ 60 \times 1 \times 4.24$

$= 708 \text{ in-KIPS} = 59 \text{ ft-KIPS}$

SOLVE FOR ADDITION POINTS BETWEEN P_o AND BALANCED POINT AND BETWEEN BALANCED POINT AND M_o

P_n (KIPS)

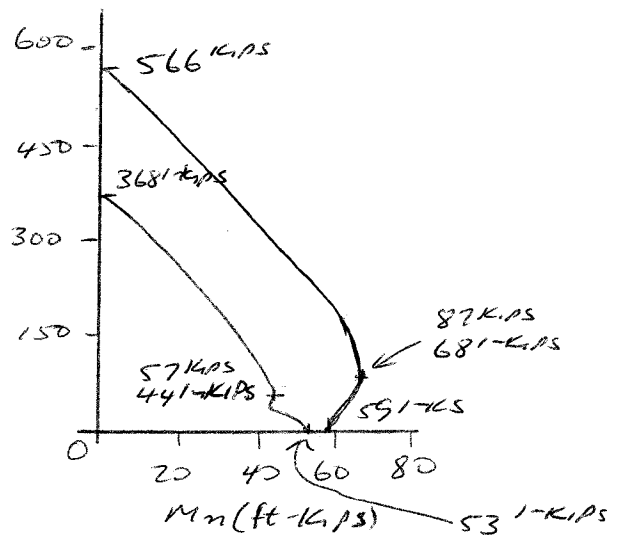

8.10 AXIAL LOAD w/ BIAXIAL BENDING

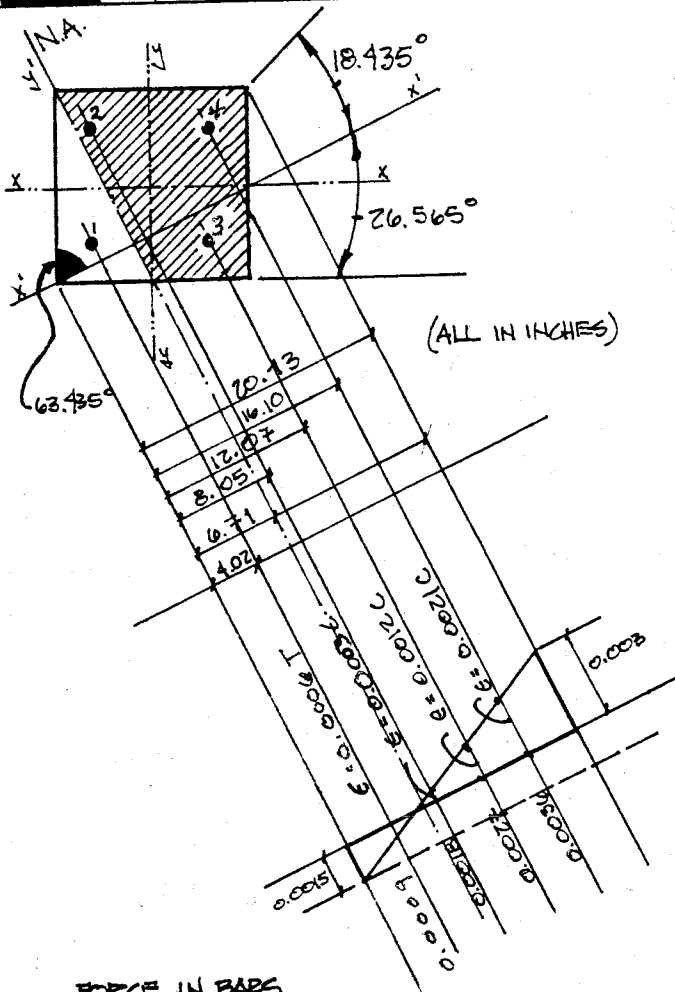

TOTAL AXIAL LOAD = $19.58 + 78.3 + 135.0 + 191.3 + 286.3 - 39.15 = 671.3 \text{ KIPS}$

MOMENT ABOUT X AXIS	MOMENT ABOUT Y AXIS
(T) 39.15×4.5	(T) 39.15×4.5
+ (C) 19.58×4.5	+ (C) 78.3×4.5
+ (C) 135.0×4.5	+ (C) 135×4.5
+ (C) 191.3×2.5	+ (C) 286.3×4.87
- (C) 78.3×4.5	- (C) 191.3×0.26
= 998 IN-K	- (C) 19.58×4.5
	= 2392 IN-K

$P_H = 671 \text{ KIPS}$
 $M_{Nx} = 998 \text{ IN-KIPS}$
 $M_{Ny} = 2392 \text{ IN-KIPS}$
 $e_x = 1.49 \text{ IN}$
 $e_y = 3.56 \text{ IN}$

ANGLE BETWEEN NA & ECCENTRICITY AXES

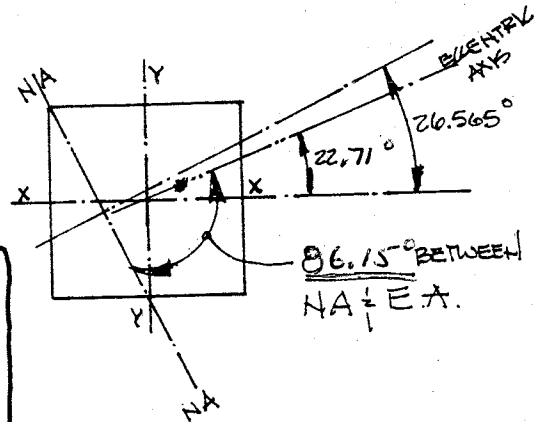

FORCE IN BARS

- 1. (T) $0.0006 \times 29000 \times 2.25 = 17.4 \text{ KSI} \times 2.25 = 39.15 \text{ K}$
- 2. (C) $0.0008 \times 29000 \times 2.25 = 8.7 = 19.58 \text{ K}$
- 3. (C) $0.0012 \times 29000 \times 2.25 = 34.8 = 78.3 \text{ K}$
- 4. (C) $0.0021 \times 29000 \times 2.25 = 60.9 = 135 \text{ K}$

COMPRESSION IN CONCRETE

$2.24 C = 20.13 - 6.71 = 13.42 \text{ IN.}$ $B, C = 11.41 \text{ IN.}$

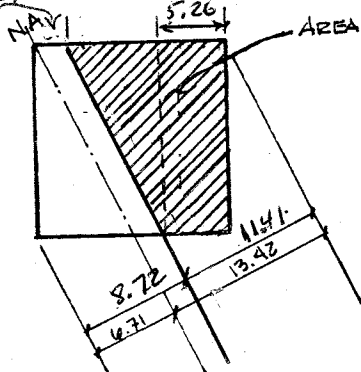

AREA OF STRESS BLOCK.

$C_1 = 5.26 \times 15 \times 0.85 \times 4 = 286.3 \text{ KIPS}$

$C_2 = \frac{1}{2} \times 7.5 \times 15 \times 0.85 \times 4 = 191.3 \text{ KIPS}$

$$\underline{8.11} \quad P_n = 671 \text{ kips} \quad K_n = \frac{671}{4 \times 225} = 0.746$$

$$\gamma = \frac{9}{15} = 0.6 \quad \text{USE GRAPH A.9}$$

$$\rho_g = \frac{9}{15 \times 15} = 0.04$$

$$\frac{e_y}{e_x} = \frac{3.56}{1.49} = 2.389$$

$$\left(\frac{M_{nx}}{M_{nx0}} \right)^{1.3} + \left(\frac{M_{ny}}{M_{ny0}} \right)^{1.3} = 1.0$$

$$M_{nx} = P_n e_x = 671 e_x \quad ; \quad M_{ny} = P_n e_y = 2.389 P_n e_x = 1603 e_x$$

FROM GRAPH A.11 $R_n = 0.203$ FOR $\rho_g = 0.04$ + $K_n = 0.746$

$$M_{nx0} = M_{ny0} = 0.203 \times 4 \times 225 \times 15 = 2740 \text{ ''-K}$$

$$\left(\frac{671 e_x}{2740} \right)^{1.3} + \left(\frac{1603 e_x}{2740} \right)^{1.3} = 1.0$$

$$e_x^{1.3} = 1.518'' \quad \rightarrow \quad e_x = 1.38'' \quad , \quad e_y = 3.29''$$

THUS, THE PREDICTED CAPACITY IS SLIGHTLY LESS THAN OBTAINED IN PROBLEM 8.9.

8.12

$$e_x = 1.49'' \quad e_y = 3.56''$$

$$y = \frac{9}{15} = 0.60$$

$$\text{USING GRADH A.9, } P_0 = 1.415 \times 4 \times 225 = 1274 \text{ KIPS}$$

$$R_{mx} = \frac{P_m \times 1.49}{4 \times 225 \times 15} = 0.1104 \times 10^{-3} P_m$$

$$R_{my} = \frac{P_m \times 3.56}{4 \times 225 \times 15} = 0.2637 \times 10^{-3} P_m$$

$$\frac{1}{P_m} = \frac{1}{P_{mx0}} + \frac{1}{P_{my0}} - \frac{1}{P_0}$$

TRY $P_m = 671 \text{ KIPS}$ FROM PROBLEM 8.9

$$R_{mx} = 0.0741 \rightarrow P_{mx0} = 1.195 \times 4 \times 225 = 1075$$

$$R_{my} = 0.1769 \rightarrow P_{my0} = 0.865 \times 4 \times 225 = 779$$

$$\frac{1}{P_m} = \frac{1}{1075} + \frac{1}{779} - \frac{1}{1274} \rightarrow P_m = 700 \text{ KIPS}$$

TRY $P_m = 685 \text{ KIPS}$

$$R_{mx} = 0.0756 \rightarrow P_{mx0} = 1.19 \times 900 = 1071$$

$$R_{my} = 0.1806 \rightarrow P_{my0} = 0.845 \times 900 = 760$$

$$P_m = 683 \text{ KIPS} \rightarrow P_{m \text{ FINAL}} = 684 \text{ KIPS}$$

THE VALUE OBTAINED WITH THE RECIPROCAL LOAD METHOD IS SLIGHTLY GREATER, BUT WITHIN 2% OF THAT OBTAINED IN PROBLEM 8.9 - THE SOLUTION USING THE LOAD CONTROL METHOD FOR THIS PROBLEM IS SOMEWHAT MORE CONSERVATIVE - OVERALL, THE ACCURACY IS QUITE ADEQUATE -

8.13

Because $\frac{M_x}{M_y} \leq 0.2$, design for uniaxial bending -

Assume No. 10 (No. 32) bars + No. 3 (No. 10) ties

$$\gamma = \frac{20 - 2 \times 1\frac{1}{2} - 2 \times \frac{3}{8} - 1.27}{20} = 0.75$$

$$\text{At max } P_u, \quad K_m = \frac{880}{0.65 \times 4 \times 400} = 0.85$$

$$R_m = \frac{295 \times 12}{0.65 \times 4 \times 400 \times 20} = 0.17$$

Use Graphs A.6 ($\gamma = 0.7$) and A.7 ($\gamma = 0.8$)

$$\gamma = 0.7 \quad \rho = 4.0\%$$

$$\gamma = 0.8 \quad \rho = 3.6\%$$

$$\text{Use } \rho = 3.8\%$$

$$A_{st} = 0.038 \times 400 = 15.2 \text{ in}^2$$

$$\text{Use 12 No. 10 (No. 32) bars, } A_{st} = 15.24 \text{ in}^2$$

$$\text{Check min } P_u - K_m = \frac{551}{0.65 \times 4 \times 400} = 0.52$$

$$\gamma = 0.7 \quad \rho = 2.4\% \quad \left. \vphantom{\gamma = 0.7} \right\} \text{OK}$$

$$\gamma = 0.8 \quad \rho = 2.0\%$$

Use No. 3 ties

$$\text{Spacing} \leq 16 \times 1.27 = 20.3 \text{ in.}$$

$$\leq 48 \times 0.375 = 18 \text{ in.} \leftarrow \text{controls}$$

$$\leq 20 \text{ in.}$$

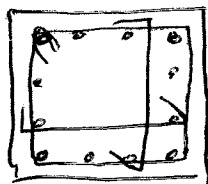

Use at least 2 cross-ties

8.14 use $\gamma = 0.7$

$$\frac{M_x}{M_y} = \frac{104}{110} = 0.95 > 0.20 \text{ } \therefore \text{ must design for biaxial bending -}$$

$$A_g = 16^2 = 256 \text{ in}^2$$

$$K_m = \frac{209}{0.65 \times 4 \times 256} = 0.31$$

$$R_{m\gamma} = \frac{110}{0.65 \times 4 \times 256 \times 6} = 0.124$$

Using Graph A.6 ($\gamma = 0.7$), $\rho < 0.01$ for $\phi = 0.65$

Assume $\phi = 0.9$ for $P_u = 130 \text{ kips}$

$$K_m = \frac{130}{0.9 \times 4 \times 256} = 0.14, \quad \epsilon_t > 0.005, \quad \phi = 0.9 \text{ OK}$$

$+ \rho_s = 0.015$

$$\frac{P}{P_o} < 0.1 \rightarrow \text{use Load Contour Method}$$

(use $\alpha = 1.15$)

Because of biaxial bending, use $\rho_s = 0.025$.

$$\text{For } K_m = 0.14 + \rho_s = 0.025, \quad R_m = 0.17$$

$$\begin{aligned} M_m = M_{mxo} = M_{myo} &= R_m \phi f'_c A_g h \\ &= 0.17 \times 0.9 \times 4 \times 256 \times 16 = 2506 \text{ in-kips} \\ &= 209 \text{ ft-kips} \end{aligned}$$

$$\left(\frac{110}{209}\right)^{1.15} + \left(\frac{104}{209}\right)^{1.15} = 0.93 \text{ OK}$$

$$A_{st} = 0.025 \times 256 = 6.4 \text{ in}^2$$

USE 8 No. 8 (No. 25) bars, $A_{st} = 6.32 \text{ in}^2$
- close enough

USE No. 3 (No. 10) ties

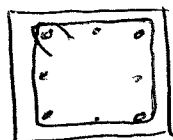

$$\begin{aligned} \text{Spacing} &\leq 16 \times 1 = 16 \text{ in. } \leftarrow \\ &\leq 48 \times 0.375 = 18 \text{ in.} \\ &\leq 16 \text{ in. } \leftarrow \end{aligned}$$

9.1

$$P_u = 1.2 \times 170 + 1.6 \times 100 = 364 \text{ KIPS}$$
$$M_{u \text{ TOP}} = 1.2 \times 29 + 1.6 \times 50 = 114.8 \text{ KIPS}$$
$$M_{u \text{ BOT}} = 1.2 \times 14.5 + 1.6 \times 25 = 57.4 \text{ KIPS}$$

$$\frac{kl_u}{r} = \frac{0.9 \times 20.5 \times 12}{0.3} = 49.2$$

$$34 - 12 \frac{M_1}{M_2} = 34 - 12 \left(\frac{-57.4}{114.8} \right) = 40 \rightarrow \text{CONSIDER SLENDERNESS EFFECTS}$$

$$E_c = 57000 \sqrt{4000} / 1000 = 3.6 \times 10^3 \text{ KSI}$$

$$\beta_{dns} = \frac{1.2 \times 170}{364} = 0.56$$

$$EI = \frac{0.4 E_c I_g}{1 + \beta_{dns}} = \frac{0.4 \times 3.6 \times 10^6 \times 15 \times 15^3 / 12}{1 + 0.56} = 3.89 \times 10^9 \text{ in}^2 \text{ lb}$$

$$P_c = \frac{\pi^2 EI}{(kl_u)^2} = \frac{\pi^2 \times 3.89 \times 10^9}{(0.9 \times 20.5 \times 12)^2} = 7.83 \times 10^5 \text{ lb}$$

$$\delta_{ms} = \frac{C_m}{1 - P_u / 0.75 P_c} = \frac{0.4}{1 - \frac{364}{0.75 \times 783}} = 1.05 < 1.4 \checkmark$$

$$M_c = \delta_{ms} M_2 = 1.05 \times 114.8 = 121 \text{ KIPS}$$

$$K_m = \frac{P_u}{\phi F_c A_g} = \frac{364}{0.65 \times 4 \times 225} = 0.622$$

$$R_m = \frac{M_u}{\phi F_c A_g L} = \frac{121}{0.65 \times 4 \times 225 \times 15} = 0.166$$

$$y = (15 - 2 \times 2 - 2 \times 0.375 - 1.27) / 15 = 0.60$$

$$\rho_g = 6 \times 1.27 / 225 = 0.034$$

FROM GRAPH A.10, NEEDED $\rho_g = 0.021$

SO ACTUAL $\rho_g = 0.034$ IS SAFE -

$$9.2 \quad P_u = 1.2 \times 139 + 1.6 \times 93 = 316 \text{ kips}$$

$$M_{u \text{ TOP}} = 1.2 \times 61 + 1.6 \times 41 = 139 \text{ kips}$$

$$M_{u \text{ BOT}} = 1.2 \times 41 + 1.6 \times 27 = 92 \text{ kips}$$

$$y = (16 - 2 \times 1.5 - 2 \times 0.375 - 1.41) / 16 = 0.68$$

$$\rho_s = 6 \times 1.56 / 16^2 = 0.037$$

$$I_{\text{COL}} = 0.7 \times 16 \times 16^3 / 12 = 3823 \text{ in}^4$$

$$I_{\text{col}}/I_c = 3823 / (22 \times 12) = 14.48 \text{ in}^3$$

$$+ = 3823 / (12 \times 12) = 26.55 \text{ in}^3$$

$$I_{\text{BEAM}} = 0.35 \times 2 \times 24 \times 18^3 / 12 = 8165 \text{ in}^4$$

$$I/I_c = 8165 / (22 \times 12) = 30.93$$

$$\psi_A = \psi_B = \frac{14.48 + 26.55}{30.93} = 1.33$$

From ALIGNMENT CHART, $k = 0.81$

$$\frac{k l_u}{r} = \frac{0.81 \times 22 \times 12}{0.3 \times 16} = 44.55$$

$$34 - 12 \frac{M_1}{M_2} = 34 - 12 \left(\frac{92}{139} \right) = 26 \rightarrow \text{CONSIDER SLENDERNESS}$$

$$C_m = 0.6 + 0.4 \frac{M_1}{M_2} = 0.6 + 0.4 \left(\frac{92}{139} \right) = 0.865$$

$$\beta_{\text{dns}} = \frac{1.2 \times 139}{316} = 0.53; \quad f'_c = 4800 \text{ psi} \rightarrow E_c = 3.6 \times 10^3 \text{ ksi}$$

$$EI = \frac{0.4 E_c I}{1 + \beta_{\text{dns}}} = \frac{0.4 \times 3.6 \times 10^6 \times 16 \times 16^3 / 12}{1 + 0.53} = 5.14 \times 10^9 \text{ in}^2 \cdot \text{lb}$$

$$P_c = \frac{\pi^2 \times 5.14 \times 10^9}{(0.81 \times 22 \times 12)} = 1.11 \times 10^6 \text{ lb} \rightarrow 1110 \text{ kips}$$

$$\delta_{\text{ms}} = \frac{C_m}{1 - P_u / (0.75 P_c)} = \frac{0.865}{1 - \frac{316}{0.75 \times 1110}} = 1.394$$

$$M_c = \delta_{\text{ms}} M_2 = 1.394 \times 139 = 194 \text{ kips}$$

$$K_m = \frac{P_u}{\phi f_c A_g} = \frac{316}{0.65 \times 4 \times 256} = 0.47$$

$$R_m = \frac{M_u}{\phi f_c A_g h} = \frac{194 \times 12}{0.65 \times 4 \times 256 \times 16} = 0.22$$

From GRAPHS: A.10 For $y = 0.60$: $\rho_s = 0.034$

A.11 For $y = 0.70$: $\rho_s = 0.026$

For $y = 0.68$, $\rho_s = 0.028$

COLUMN IS OK -

9.3 CONTINUING FROM PROBLEM 9.2,

$$EI = \frac{0.2 E_c I_g + E_s I_{se}}{1 + \beta_{dns}}$$

$$I_s = 9.36 \times (8 - 1.5 - 0.375 - 1.41/2)^2 = 275 \text{ in}^4$$

$$EI = \frac{0.2 \times 3.6 \times 10^6 \times 16 \times 16^3 / 12 + 29 \times 10^6 \times 275}{1 + 0.53}$$
$$= 7.78 \times 10^9 \text{ in}^2 \cdot \text{lb}$$

$$P_c = \frac{7.78}{5.14} \times 1.11 \times 10^6 \text{ lb} = 1.68 \times 10^6 \text{ lb}$$

$$\delta_{ms} = \frac{0.865}{1 - \frac{316}{0.75 \times 1680}} = 1.15$$

$$M_c = 1.15 \times 139 = 160 \text{ kips}$$

$$K_m = 0.47 \text{ AS BEFORE}$$

$$R_m = \frac{M_u}{\phi f'_c A_g h} = \frac{160 \times 12}{0.65 \times 4 \times 256 \times 16} = 0.18$$

FROM GRAPHS: A.10 FOR $\gamma = 0.60$: $\rho_s = 0.025$

A.11 FOR $\gamma = 0.70$: $\rho_s = 0.020$

FOR $\gamma = 0.68$, $\rho_s = 0.021$

THE MORE ACCURATE VALUE OF P_c GIVES LESS MOMENT MAGNIFICATION, INDICATING THAT THE COLUMN HAS A LOT OF EXTRA CAPACITY.

SIGNIFICANT STEEL SAVINGS ARE POSSIBLE -

9.4 $l_u = 20'$

$P_u = 1.2 \times 180 + 1.6 \times 220 = 568 \text{ KIPS}$

$M_{u \text{ TOP}} = 1.2 \times 28 + 1.6 \times 112 = 213.1 \text{ KIPS}$

$M_{u \text{ BOT}} = 1.2 \times (-28) + 1.6 \times 112 = 146.1 \text{ KIPS}$

TRY 20x20 COLUMN

GIVEN: $\psi_A = \psi_B = 1$, FROM ALIGNMENT CHART, $K \approx 0.775$

$\frac{K l_u}{r} = \frac{0.775 \times 240}{0.3 \times 20} = 31$

COMPARE TO $34 - 12 \left(\frac{146}{213} \right) = 25.8 < 31$ MUST CONSIDER SLENDerness

ASSUME $\delta_{ms} = 1.1$

$M_c = 1.1 \times 213 = 234.1 \text{ KIPS}$

$K_m = \frac{P_u}{\phi f'_c A_g} = \frac{568}{0.65 \times 4 \times 400} = 0.546$; $R_m = \frac{M_u}{\phi f'_c A_g h} = \frac{234 \times 12}{0.65 \times 4 \times 400 \times 20} = 0.135$

ASSUME No. 8 BARS $\rightarrow \gamma = (20 - 2 \times 1.5 - 2 \times 0.375 - 1.0) / 20 = 0.7625$

FOR $\gamma = 0.70$, USING GRAPH A.6: $\rho_s = 0.013$

FOR $\gamma = 0.80$, USING GRAPH A.7: $\rho_s = 0.011$

FOR $\gamma = 0.7625$, $\rho_s = 0.0118 \rightarrow A_{st} = 4.7 \text{ in}^2$

USE 8 No. 7 BARS $A_{s \text{ PROVIDED}} = 4.8 \text{ in}^2 \rightarrow \gamma = 0.77 \text{ OK}$

$\beta_{dns} = \frac{1.2 \times 180}{568} = 0.38$

$EI = \frac{0.4 \times 3.6 \times 10^6 \times 20 \times 20^3 / 12}{1 + 0.38} = 13.91 \times 10^9 \text{ in}^2 \cdot \text{lb}$

$P_c = \frac{\pi^2 \times 13.91 \times 10^9}{(0.775 \times 20 \times 12)^2} = 3.968 \times 10^6 \text{ lb} = 3968 \text{ KIPS}$

$C_m = 0.6 + 0.4 \left(\frac{146}{213} \right) = 0.874$

$\delta_{ms} = \frac{0.874}{1 - \frac{568}{0.75 \times 3968}} = 1.08 \checkmark \text{ OK}$

NOTE: DROPPING TO 19x19 REQUIRES AN INCREASE IN REINFORCEMENT TO 8 No. 9 BARS - STAY WITH 20x20

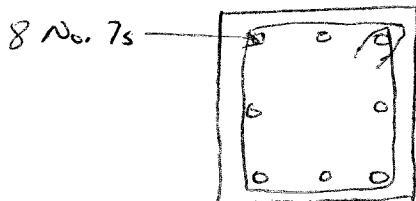

No. 3 ties

$S \leq 20''$

$\leq 16 \times 7/8 = 14'' \leftarrow \text{CONTROLS}$

$\leq 48 \times 3/8 = 18''$

$$9.5 \quad V_{us} = 1.6 \times 53.5 = 85.6 \text{ KIPS}$$

$$\Delta_0 = 1.6 \times 0.24 = 0.384''$$

IGNORE WIND LOADS TO CALC. ΣP_u FOR STORY
COLS A2+E2 $P_u = 1.2 \times 348 + 1.0 \times 13 = 555 \text{ KIPS}$

$$B2 + D2 \quad P_u = 1.2 \times 757 + 1.0 \times 307 = 1215$$

$$C2 \quad P_u = 1.2 \times 688 + 1.0 \times 295 = 1121$$

$$\Sigma P_u = 2 \times 555 + 2 \times 1215 + 1121 = 4661$$

$$Q = \frac{\Sigma P_u \Delta_0}{V_{us} L_c} = \frac{4661 \times 0.384}{85.6 \times 16 \times 12} = 0.109$$

$Q > 0.05 \rightarrow$ SWAY FRAME ANALYSIS IS REQUIRED

GRAVITY LOADS ONLY - B2/D2

$$P_u = 1.2 \times 757 + 1.6 \times 307 = 1400 \text{ KIPS}$$

$$M_2 = 1.2 \times 31 + 1.6 \times 161 = 295 \text{ KIPS}$$

$$M_1 = 1.2 \times (-31) + 1.6 \times 108 = 136 \text{ KIPS}$$

$$\frac{k l_u}{r} = \frac{1.0 \times 14 \times 12}{0.3 \times 24} = 23.3$$

$$34 - 12 \frac{M_1}{M_2} = 34 - 12 \left(\frac{136}{295} \right) = 28.5 > \frac{k l_u}{r}$$

THEREFORE, SLENDERNESS NEED NOT BE CHECKED

$$k_m = \frac{P_u}{\phi F_c A_g} = \frac{1400}{0.65 \times 4 \times 576} = 0.935 \quad P_m = \frac{M_u}{\phi F_c A_g h} = \frac{295 \times 12}{0.65 \times 4 \times 576 \times 24} = 0.0985$$

ASSUME $\gamma = 0.75 \rightarrow$ FROM GRAPH A.6 ($\gamma = 0.70$) $\rho_s = 0.027$

FROM GRAPH A.7 ($\gamma = 0.80$) $\rho_s = 0.025$

$$\text{FOR } \gamma = 0.75, \rho_s = 0.026$$

$$A_{st} = 0.026 \times 576 = 14.98 \text{ in}^2$$

$$\text{USE 12 NO. 10} = 15.24 \text{ in}^2$$

GRAVITY PLUS WIND LOADS - BY INSPECTION,

SLENDERNESS MUST BE CONSIDERED SINCE $\frac{k l_u}{r} > 22$

$$M_{2s} = 1.6 \times 105 = 168 \text{ KIPS}$$

$$\delta_s M_{2s} = \frac{168}{1-Q} = \frac{168}{1-0.109} = 189 \text{ KIPS}$$

$$M_{2ms} = 1.2 \times 31 + 1.0 \times 161 = 198 \text{ KIPS}$$

9.5 CONTINUED

$$M_2 = 198 + 189 = 387 \text{ KIPS}$$

$$P_u = 1.2 \times 757 + 1.0 \times 307 + 1.6 \times 9 = 1230 \text{ KIPS}$$

$$K_m = \frac{P_u}{\phi f_c A_g} = \frac{1230}{0.65 \times 4 \times 576} = 0.821$$

$$R_m = \frac{M_u}{\phi f_c A_g h} = \frac{387 \times 12}{0.65 \times 4 \times 576 \times 24} = 0.129$$

From GRAPH A.6 ($\gamma = 0.70$) $\rho_s = 0.027$ } 0.025
GRAPH A.7 ($\gamma = 0.80$) $\rho_s = 0.023$ }

THE ORIGINAL DESIGN CONTROLS

9.6 CONTINUING THE CALCULATIONS FROM PROBLEM 9.5,

COLS BZ, DZ + CZ

$$I = 0.70 \times 24 \times 24^3 / 12 = 19,354 \text{ in}^4; I/c = \frac{19354}{16 \times 12} = 101$$

COLS AZ + EZ

$$I = 0.70 \times 20 \times 20^3 / 12 = 9333 \text{ in}^4; I/c = \frac{9333}{16 \times 12} = 49$$

GIRDERS

$$I = 21 \times 20^3 / 12 = 29030 \text{ in}^4; I/c = 105$$

9.7 RESOLVE EXAMPLE 9.2 WITH $l_c = 16'$, $l_u = 15'$ AND LATERAL STORY DEFLECTION = 1.10"

$$V_{us} = 1.6 \times 55 = 88 \text{ KIPS}$$

$$\Delta_o = 1.6 \times 1.10 = 1.76''$$

$$\text{COLS A3+F3 } P_u = 228 \text{ KIPS}$$

$$\text{B3, C3, D3, F3 } P_u = 449 \text{ KIPS}$$

$$\Sigma P_u = 2 \times 228 + 4 \times 449 = 2252 \text{ KIPS}$$

$$Q = \frac{\Sigma P_u \Delta_o}{V_{us} l_c} = \frac{2252 \times 1.76}{88 \times 16 \times 12} = 0.235$$

$Q > 0.05 \rightarrow$ SWAY FRAME ANALYSIS REQUIRED

GRAVITY PLUS WIND LOADS

$$S_s M_{2S} = \frac{M_{2S}}{1-Q} = \frac{134}{1-0.235} = 1751 \text{ KIPS}$$

$$M_2 = 110 + 175 = 2851 \text{ KIPS}$$

$$K_m = \frac{P_u}{\phi F_c A_g} = \frac{459}{0.65 \times 4 \times 324} = 0.545$$

$$R_m = \frac{M_u}{\phi F_c A_g h} = \frac{285}{0.65 \times 4 \times 324 \times 18} = 0.226$$

USING GRAPH A.6 ($\gamma = 0.7$), $\rho_g = 0.042$

$$A_{st} = 0.042 \times 324 = 13.61 \text{ in}^2$$

USE 4 NO. 11 + 8 NO. 9 BARS, GIVING 14.24 in²

REQUIRES NO. 4 TIES. $\{ 5 \leq 18''$, $48 \times 0.5 = 24''$, $16 \times 1.28 = 18'' \} @ 18''$

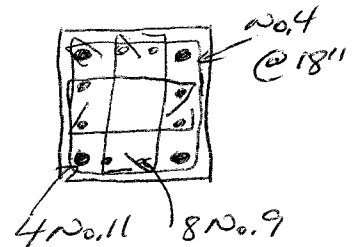

9.8

$$V_u = 1.6 \times 110 = 176 \text{ kips}$$

$$\Delta_o = 1.6 \times 0.40 = 0.64 \text{ in.}$$

15 more wind loads to calc. ΣP_u for story

$$A1+F1 \quad P_u = 1.2 \times 495 + 1.0 \times 99 = 693 \text{ kips}$$

$$B1+E1 \quad P_u = 1.2 \times 1090 + 1.0 \times 206 = 1514$$

$$C1+D1 \quad P_u = 1.2 \times 989 + 1.0 \times 188 = 1375$$

$$\Sigma P_u = 2(693 + 1514 + 1375) = 7164 \text{ kips}$$

$$Q = \frac{\Sigma P_u \Delta_o}{V_u \Delta_c} = \frac{7164 \times 0.64}{176 \times 22.25 \times 12} = 0.098$$

$Q > 0.05 \rightarrow$ Sway frame analysis as required

Gravity loads only on B1+E1

$$P_u = 1.2 \times 1090 + 1.6 \times 206 = 1638 \text{ kips}$$

$$M_u = 1.2 \times 4 + 1.6 \times 70 = 117 \text{ ft-kips}$$

$$\frac{K L_u}{r} = \frac{1.0 \times 22 \times 12}{0.3 \times 26} = 33$$

$$34 - 12 \frac{M_u}{M_2} = 34 - 12 \frac{1.2(-2) + 1.6(-35)}{1.2(4) + 1.6(70)} = 40 > \frac{K L_u}{r}$$

Therefore, slenderness need not be checked -

$$K_m = \frac{P_u}{\phi F_c A_g} = \frac{1638}{0.65 \times 4 \times 676} = 0.932$$

$$R_m = \frac{M_u}{\phi F_c A_g h} = \frac{117 \times 12}{0.65 \times 4 \times 676 \times 26} = 0.0307$$

Assume $\gamma = 0.8$

From Graph A.7, $\rho_s = 0.022$

$$A_{st} = 0.022 \times 676 = 14.87, \text{ use 12 No. 10 } A_{st} = 15.24$$

Gravity plus wind loads - By inspection, slenderness must be considered since $\frac{K L_u}{r} > 22$.

$$\delta_s = \frac{1}{1-Q} = \frac{1}{1-0.098} = 1.109; M_s = 1.6 \times 240 = 384 \text{ ft-kips}$$

$$M_{ns} = 1.2 \times 4 + 1.0 \times 70 = 75 \text{ ft-kips}$$

9.8 Continued

$$M_z = 75 + 426 = 501 \text{ ft-kips}$$

$$P_u = 1.2 \times 1090 + 1.0 \times 206 + 1.6 \times 19 = 1544 \text{ kips}$$

$$K_m = \frac{1544}{0.65 \times 4 \times 676} = 0.879; R_m = \frac{501 \times 2}{0.65 \times 4 \times 676 \times 26} = 0.132$$

From Graph A.7, $\rho_s = 0.028$

$$A_{st} = 0.028 \times 676 = 18.93 \text{ in.}^2$$

Use 12 No. 11, $A_{st} = 18.72 \text{ in.}^2$ or 4 No. 14 + 8 No. 10, $A_{st} = 19.16 \text{ in.}^2$

Use No. 4 ties [spacing $\leq 26 \text{ in.}$, $\leq 48 \times 0.5 = 24$,
 $\leq 16 \times 1.41 = 22.5$] use 22 in.

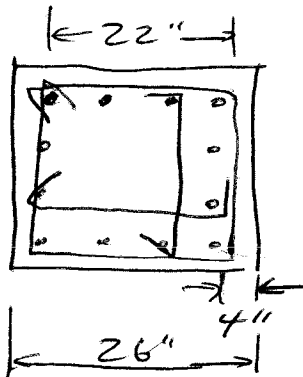

$$\frac{26 - 4 - 3 \times 1.41}{3} = 5.92 < 6 \text{ in.} - \text{OK}$$

single cross tie required
in each direction

Instructor's Solutions Manual

to accompany

Design of Concrete Structures, 14e

Nilson/Darwin/Dolan

Chapters 10-12

The authors welcome feedback on the problem solutions and on the text in general. Please e-mail any comments to David Darwin at: daved@ku.edu

PROPRIETARY AND CONFIDENTIAL

This Manual is the proprietary property of The McGraw-Hill Companies, Inc. ("McGraw-Hill") and protected by copyright and other state and federal laws. By opening and using this Manual the user agrees to the following restrictions, and if the recipient does not agree to these restrictions, the Manual should be promptly returned unopened to McGraw-Hill: This Manual is being provided only to authorized professors and instructors for use in preparing for the classes using the affiliated textbook. No other use or distribution of this Manual is permitted. This Manual may not be sold and may not be distributed to or used by any student or other third party. No part of this Manual may be reproduced, displayed or distributed in any form or by any means, electronic or otherwise, without the prior written permission of the McGraw-Hill.

$$10.1 \quad f'_c = 5000 \text{ psi}, f_y = 60,000 \text{ psi}$$

$$R_B = 1600 \left(\frac{24}{36} \right) = 1067 \text{ k}$$

$$R_C = 1600 \frac{12}{36} = 533 \text{ k}$$

Check section shear capacity.

$$\begin{aligned} V_{\max} &= \phi 10 \sqrt{f'_c} b d \\ &= 0.75 (10) \frac{\sqrt{5000}}{1000} 24 \cdot 120 \\ &= 1527 \text{ k} > R_B = 1067 \text{ k} \quad \text{OK} \end{aligned}$$

Node stress limits

$$\text{CCC Node} \quad \beta_n = 1$$

$$\begin{aligned} \phi f_{cu} &= \phi \cdot 0.85 \beta_n f'_c \\ &= 0.75 (0.85) (1) \frac{5000}{1000} \\ &= 3.19 \text{ ksi} \end{aligned}$$

$$\text{CCT node} \quad \beta_n = 0.80$$

$$\begin{aligned} \phi f_{cu} &= 0.75 (0.85) (0.80) 5.0 \\ &= 2.55 \text{ ksi} \end{aligned}$$

Bottle shaped strut capacity
 $\beta_s = 0.75$

$$\begin{aligned} \phi f_{cu} &= \phi \beta_s \cdot 0.85 f'_c \\ &= 0.75 (0.75) (0.85) 5.0 \\ &= 2.39 \text{ ksi} \end{aligned}$$

Size struts using bottle-shaped strut limit, The width are:

$$w_{AB} = \frac{F_{AB}}{\phi f_{cu} b} = \frac{1670}{2.39 (24)} = 29.1 \text{ in}$$

$$w_{AC} = \frac{1390}{2.39 (24)} = 24.2 \text{ in}$$

$$w_{BC} = \frac{1280}{2.39 (24)} = 22.3 \text{ in}$$

Validate assumed structural depth

$$d = 144 \text{ in} - \frac{22.4}{3} - \frac{22.3}{2} = 125 \text{ in}$$

h node A w_{BC}

$$d > 120 \text{ in assumed} \quad \text{OK.}$$

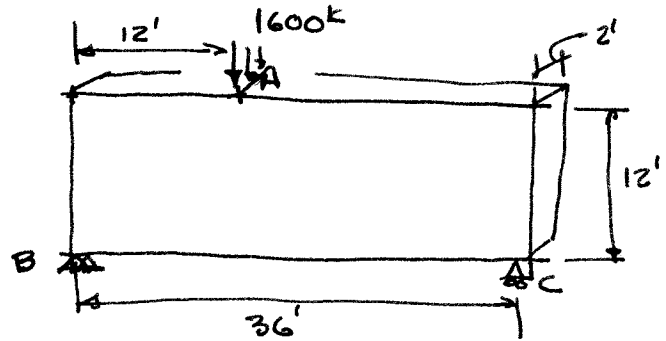

STRUCTURE

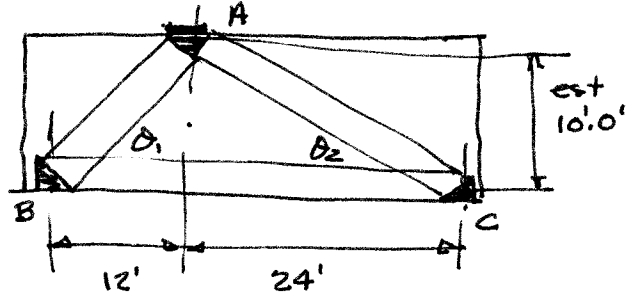

STRUT & TIE MODEL

Geometry

$$\theta_1 = \tan^{-1} \frac{10}{12} = 39.8^\circ$$

$$\theta_2 = \tan^{-1} \frac{10}{24} = 22.6^\circ$$

FORCES

$$F_{AB} = \frac{1067}{\sin 39.8} = 1670 \text{ k}$$

$$F_{AC} = \frac{533}{\sin 22.6} = 1390 \text{ k}$$

$$F_{BC} = \frac{1067}{\tan 39.8} = 1280 \text{ k}$$

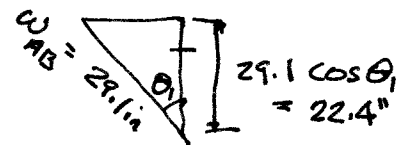

Partial Node A

10.1 (Cont.)

Check stress at column connections (Node ends are OK since $\phi \beta_n 0.85 f'_c < \phi \beta_n .85 f'_c$)

At node A $p = \frac{1600^k}{24 \times 24} = 2.78 \text{ ksi} < \phi \beta_n .85 f'_c$ for C-C-C node OK

At node B. $p = \frac{1067}{24 \times 24} = 1.85 \text{ ksi} < \phi \beta_n .85 f'_c$ for C-C-T node OK

By inspection Node C is OK

Design Tension tie

$$A_s = \frac{F_{Tc}}{\phi f_y} = \frac{1280^k}{0.75(60)} = 28.4 \text{ in}^2$$

Try 23 #10 (#32) = 29.2 in²

Check shear capacity

$A_v = 0.0025 b_s = 0.0025(24)(12) = 0.72 \text{ in}^2/\text{ft}$ Use #5(#16)@10 in

$A_h = 0.0015 b_s = 0.0015(24)(12) = 0.43 \text{ in}^2/\text{ft}$ Use #4(#13)@10 in each face

Verify placement with 5 #10 (#32) per row.

$t_{min} = 1.5 \times 2 + 2(1.62 + 1.5) + 5(1.27) + 4(2.5) = 21.6 \text{ in} < 24 \text{ in avail OK}$
cover ↑ #5 + #4 d_b #10 2d_b clear spacing

Check height

$h = 2(1.5 + 1.62) + 5(1.27) + 4(2.5) = 20.6 \text{ in} < W_{bc} = 22.3 \text{ in OK}$
↑ cover #5 stirrup d_b 2d_b spacing distance above = cover below

Use mechanical anchors or 90° hooks.

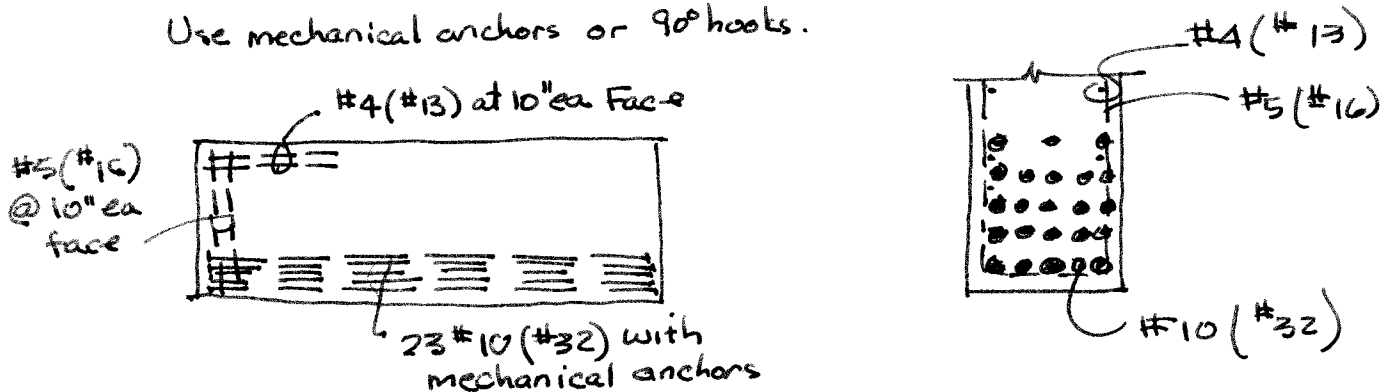

10.2 $f'_c = 5000 \text{ psi}$, $f_y = 60,000 \text{ psi}$

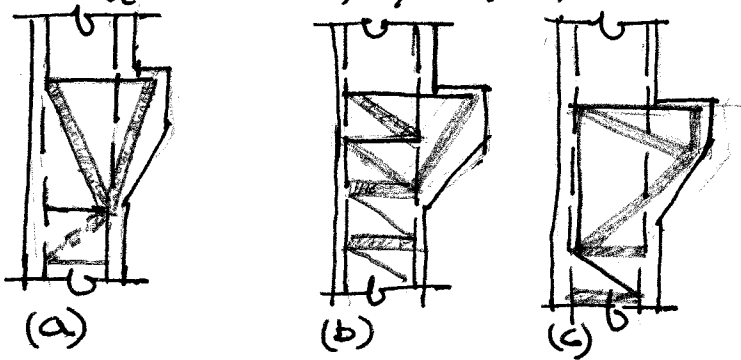

Possible strut-and-tie-models. (a) is simplest & developed

$f'_c = 5000 \text{ psi}$, $f_y = 60,000 \text{ psi}$

$$\sum M_c = 0 = 22.4(16) + 112(8) - V_A(11)$$

$$V_A = 114 \text{ k}$$

$$\sum F_x = 0 = H_c - 22.4 \text{ k} \quad H_c = 22.4 \text{ k} \leftarrow$$

$$\sum F_y = 0 = -V_A - 112 + V_c \quad V_c = 226 \text{ k}$$

$$\theta_1 = \tan^{-1} \frac{11}{15} = 36.3^\circ$$

$$\theta_2 = \tan^{-1} \frac{8}{15} = 28.1^\circ$$

Solve truss forces

$$F_{AC} = \frac{114}{\cos \theta_1} = 141.5 \text{ k}$$

$$F_{BC} = \frac{112}{\cos \theta_2} = 127 \text{ k}$$

$$F_{ab} = 141.5 \cdot \sin \theta_1 = 83.8 \text{ k}$$

Determining strut capacity for bottle shaped strut $\beta_s = 0.75$

$$\phi \beta_s 0.85 f'_c = 0.75(0.75)(0.85)(5.0) = 2.39 \text{ ksi}$$

Using a pressure of 2.39 ksi provides the following strut widths

$$w_{AC} = \frac{F_{AC}}{\phi \beta_s} = \frac{141.5}{2.39(12)} = 4.93"$$

$$w_{BC} = \frac{127}{2.39(12)} = 4.43"$$

$$w_{ab} = \frac{83.8}{2.39(12)} = 2.92"$$

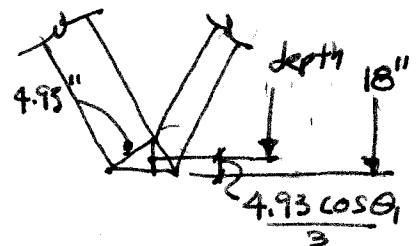

$$\text{Available height} = 18" - \frac{4.93 \cos \theta_1}{3} - 1" = 15.7" > 15" \text{ assumed OK}$$

$$\text{Design tie } A_s = \frac{F_{ab}}{\phi f_y} = \frac{83.8 \text{ k}}{0.75(60 \text{ ksi})} = 1.86 \text{ in}^2$$

Use 3 #7 (#22) = 1.80 in² and pick up difference in shear reinforcement. Use a 90° hook on left end. (cont.)

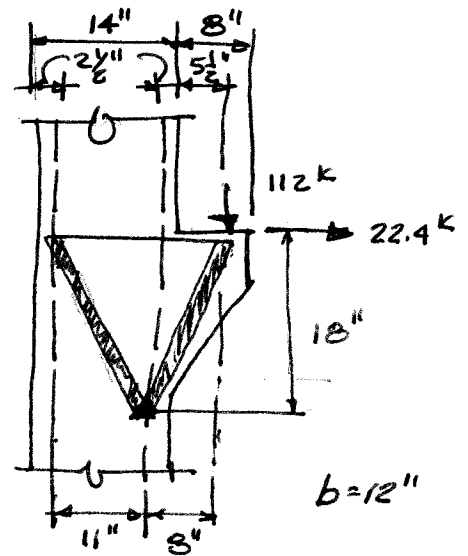

Model Geometry

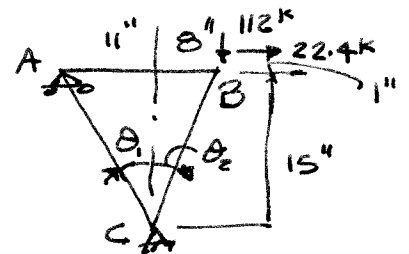

STRUCTURAL Model
Assume truss height = 15" & Overall height = 18"

10.2 (Cont.)

Check shear for bottle shaped struts

$$A_v = 0.0025 d \cdot b = .0025(18) 12 = 0.54 \text{ in}^2/\text{ft} \text{ - carry in main column reinforcement}$$

$$A_h = 0.0015 d \cdot b = .0015(18) 12 = 0.32 \text{ in}^2/\text{ft}$$

Use #4 (#13) at 15" - 2#4 (#13) in bracket

Check tensile reinforcement in column from reaction at A

$$A_s = \frac{V_u}{\phi f_y} = \frac{114}{.75(60)} = 2.53 \text{ in}^2 \quad 2\#10 (\#32) = 2.54 \text{ in}^2$$

IF column reinforcement is in compression - check capacity
 IF column reinforcement is in tension - add 2.24 in^2 and anchor above level of bracket.

Check horizontal thrust at C

$H_c = 22.4 \text{ k}$ this equates to a strut with a width of 0.78 in and a tie having an area of 0.24 in². #4 (#13) ties at 9" satisfy this requirement

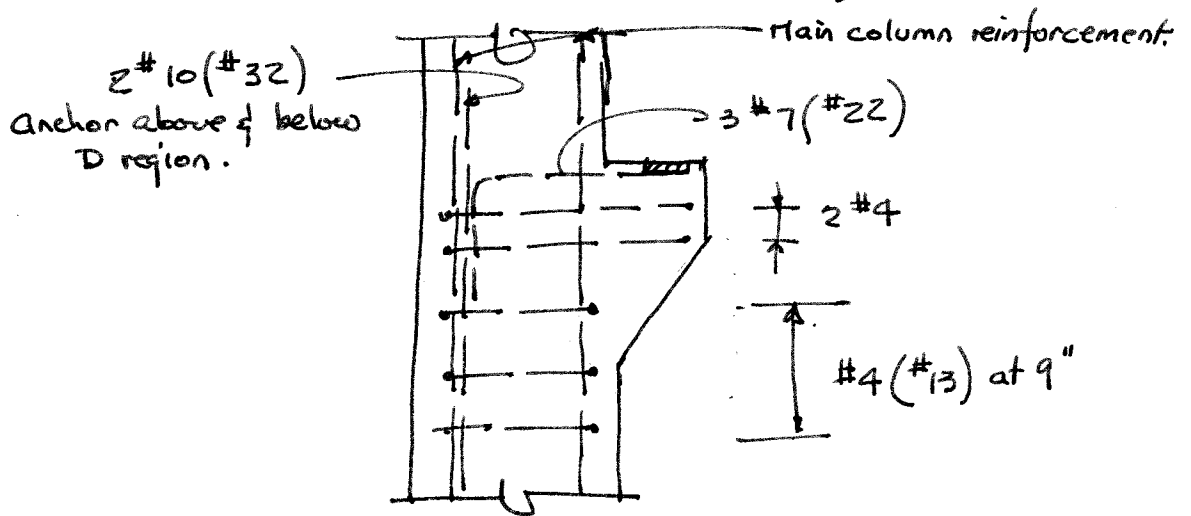

10.3 $f'_c = 6000 \text{ psi}$ $b = 6''$
 $f_y = 60,000 \text{ psi}$

$V_u = 82 \text{ k}$

$H_u = 18 \text{ k}$

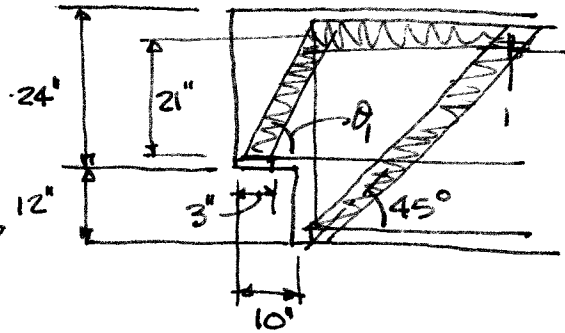
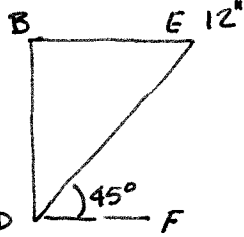
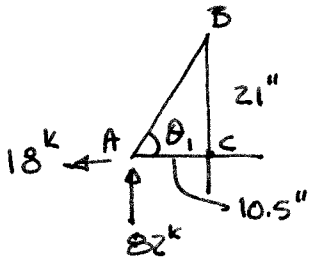

TRUSS MODEL
 ESTIMATE STRUCTURAL DEPTH = 21"

STRUCTURAL MODELS

$\theta_1 = \tan^{-1} \frac{21}{10.5} = 63.4^\circ$

$F_{AB} = \frac{82}{\sin \theta_1} = 91.68$

$F_{BE} = 91.68 \cos \theta_1 = 41.0 \text{ k}$

$F_{AC} = F_{AB} \cos \theta_1 + 18 = 91.68 \cos 63.4 + 18 = 59 \text{ k}$

$F_{BC} = 82 \text{ k} = F_{BD}$

$F_{DF} = 82 \text{ k}$

Set node and strut width for bottle shaped struts

$p = \phi \phi_s 0.85 f'_c = 0.75(0.75)(0.85)(6) = 2.87 \text{ ksi}$

$W_{ab} = \frac{F_{ab}}{p \cdot b} = \frac{91.7}{2.87(6)} = 5.32 \text{ in}$

$W_{BE} = \frac{41}{2.87(6)} = 2.38 \text{ in}$

Check height assumption

$h = 24'' - \frac{2.38}{2} - 1'' = 21.8'' > 21'' \text{ assumed ok continue design}$
 (strut BE ← horiz. steel)

Design Bearing plate

$l = \frac{V_u}{p \cdot b} = \frac{82}{2.87(6)} = 4.76 \text{ in}$ 3 in provided

Increase bearing plate to 5 inches wide x 6 in.

Design Bearing plate anchor

$A_s = \frac{F_{AC}}{\phi f_y} = \frac{59 \text{ k}}{0.75(60)} = 1.31 \text{ in}^2$

USE 2 #8 (#25) $A_s = 1.58 \text{ in}^2$

(cont.)

10.3 (Cont)

Complete bearing plate design
 To Anchor strut AB use an angle
 with a height $h_1 > W_{AB} \cos \theta_1$

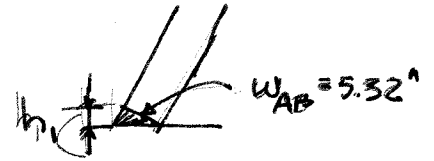

$$> 5.32 \cos 63.4 = 2.35 \text{ - Say } 2\frac{1}{2}''$$

Alternatively use headed studs ($f_y = 50 \text{ ksi}$) + shear friction

$$A_v = \frac{V_u}{\phi f_y u} = \frac{91.7 \cos 63.4}{0.75(50)(0.7)} = 1.56 \text{ in}^2$$

↑ conc on steel

Use 4 #6 (#19) headed studs $A_v = 1.76 \text{ in}^2$

Design ties for F_{BD}

$$A_s = \frac{F_{BD}}{\phi f_y} = \frac{82}{.75(60)} = 1.82 \text{ in}^2 \quad \text{use 6 \#5 (\#16)} \quad A_s = 1.86 \text{ in}^2$$

$$W_{BD} = \frac{F_{BD}}{p b} = \frac{82}{2.87(6)} = 4.76 \text{ in} \quad \text{Spacing} = 2 \text{ in}$$

Check tensile requirements at DF

$$A_s = \frac{F_{DF}}{\phi f_y} = \frac{82}{.75(60)} = 1.82 \text{ in}^2 \quad \text{- Say } 2\#9 (\#29) \text{ with mechanical anchors}$$

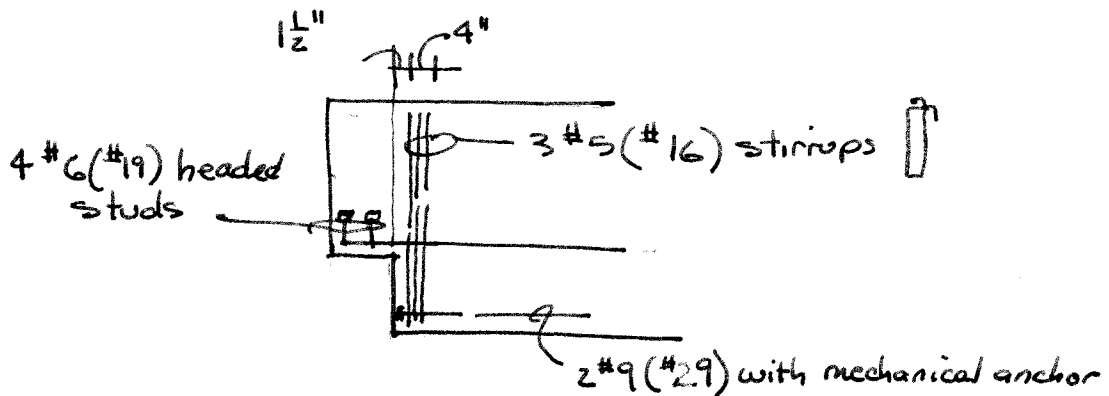

10.4 $f'_c = 5000 \text{ psi}$ $f_y = 60,000 \text{ psi}$

use $b = 16 \text{ in}$

$W_D = 1.2 w_g = 1.2 (11 \times \frac{16}{12} \times 0.15) = 2.64 \text{ klf}$

$W_S = 3.80 \text{ klf}$

$W_{\text{total}} = 6.44 \text{ klf}$

Apply distributed loads as concentrated loads 2'-c-c. Increase 1st load 50% to account for end effect.

$P = 6.44 \text{ klf} \times 2 = 12.88 \text{ k}$

$P_i = 12.88 \times 1.5 = 19.32 \text{ k}$

Assume effective depth $= 0.8h = 8.8'$

Assume bottle shaped struts, $\beta_s = 0.75$, which is more critical than a c-c-t rate $\beta_n = 0.80$. Use β_s to size struts.

$\phi = \phi \beta_s 0.85 f'_c = 0.75 (0.75) 0.85 (5.0) = 2.39 \text{ ksi}$

Strut Geometry & Loads

Strut	θ	F	$\frac{W}{\phi b}$	H
AG	$= \tan^{-1} \frac{8.8}{2} = 77.2^\circ$	$= \frac{19.3}{\sin \theta} = 19.8 \text{ k}$	$= \frac{19.8}{2.39(16)} = .52''$	$= F \cos \theta = 19.8 \cos \theta = 4.4 \text{ k}$
BG	65.6°	14.2 k	$0.37''$	5.9 k
CG	55.7°	15.6 k	$0.41''$	8.8 k
DG	47.7°	17.4 k	$0.46''$	11.7 k
EG	41.3°	19.5 k	$0.51''$	14.6 k
FG	38.7°	1600 k	$41.9''$	1250 k
				$\Sigma = 1291 \text{ k}$

Design Tension Tie

$A_s = \frac{F_{FG}}{\phi f_y} = \frac{1291}{0.75(60)} = 28.7 \text{ in}^2$

$23 \#10 (\#32) = 29.2 \text{ in}^2$

$19 \#11 (\#36) = 29.6 \text{ in}^2 \leftarrow \text{USE \& check spacing.}$

check shear

$A_v = 0.0025 bs = .0025 (16) 12 = 0.48 \text{ in}^2/\text{ft} \text{ --- } \#4 (\#13) \text{ at } 10'' = 0.48 \text{ in}^2/\text{ft}$

$A_h = 0.0015 bs = .0015 (16) 12 = 0.29 \text{ in}^2/\text{ft} \text{ --- } \#4 (\#13) \text{ at } 16'' = 0.30 \text{ in}^2/\text{ft}$

(Cont.)

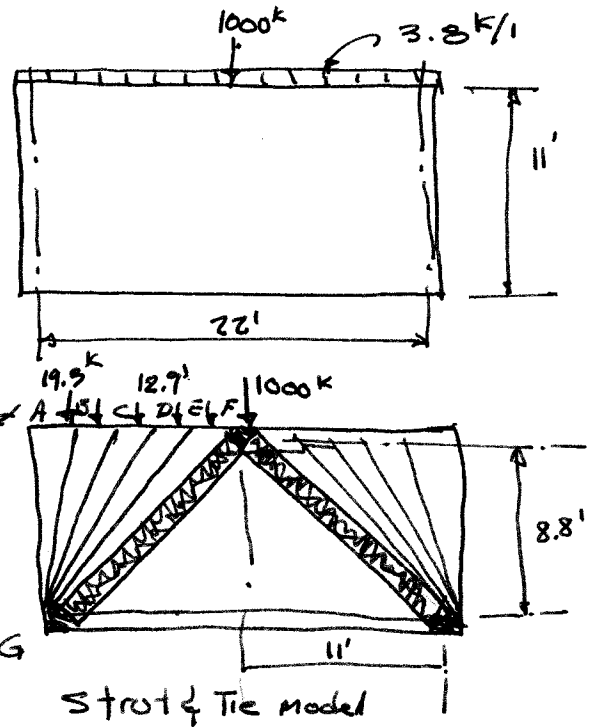

10.4 (Cont.)

Check spacing for 3 #11 (#36) per row

$$b = (1.5 + 0.5)2 + 3(1.56) + 2(2 \times 1.56) = 14.92" < 16"$$

Cover + #4 - both sides 3 bars $2d_b$ clear

16" width is OK

Number of layers $n = \frac{19}{3} = 7$ 6 layers of 3 + 1 of 1 bar.

$$\text{Vertical requirement} = \frac{1}{2} + \frac{1}{2} + 7(1.56) + 6(2 \times 1.56) = 31.6 \text{ in}$$

cover #4 #11 $2d_b$ spacing

$w_{FG} = 41.9" > \text{requirement} \therefore \text{width is sufficient}$

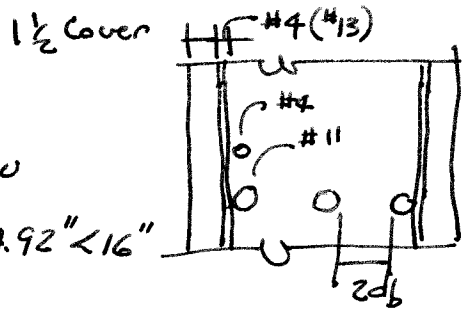

END Anchorage - Hooks or mechanical anchors are needed. If hooks are used there must be 31.6" beyond the node to separate the hooks by $2d_b$, or else use mechanical anchors

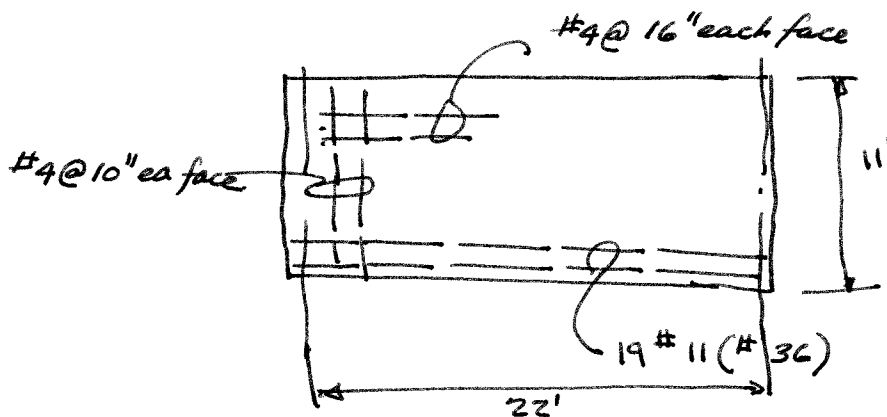

Comments.

Since struts can not cross, there is no design for loads inside the main (1000k) truss. A 12.9k load requires $A_s = \frac{12.9}{0.75(60)} = 0.29 \text{ in}^2$.

This is about half the minimum shear reinforcement, so placing loads on the bottom flange does not provide additional safety.

The 1000k column is given as 14" x 14" for a CCC node

$$\phi \rho_n (0.85 f_c') = 0.75 (1) \cdot 85 (5) = 3.19 \text{ ksi the width of}$$

the column must be: $w = \frac{1000}{3.12 (16)} = 20.03$. Hence the column should be 16 x 20 to meet code requirements

Problem 10.5

1/2

Problem 10.5 A column transfers a factored load of 700 kips to a 9-ft square footing shown in Figure P10.5, resulting in a factored uniform soil pressure of 8640 psf. Design the footing reinforcement using strut-and-tie methods. Material strengths are $f'_c = 4000$ psi and $f_y = 60,000$ psi. Because footings typically contain no shear reinforcement, your design should be based on unreinforced bottle shaped struts.

Strut and Tie data

$\beta_n = 0.8$ C-C-T Node
 $\beta_s = 0.6$ Bottle shaped strut with no shear reinforcement
 $\phi = 0.75$
width= 102 in

Material Data

$f'_c = 4000$ psi
 $f_y = 60$ ksi

Strut strength = $0.85 f'_c \times \beta_s \times \phi$

$f_{ns} = 1530$ psi

Loads = $q \times$ tributary area

$P_1 = 103.5$ kip 4 Locations
 $P_0 = 90.6$ kip 2 Locations

Geometry

	h	b	L
1	29	40.5	49.8
2	29	24.5	38.0
3	29	8.5	30.2

Strut Loads

1	155.7 kip	1.00 in
2	135.5 kip	0.87 in
3	107.8 kip	0.69 in

Strut thickness = Load/(strut strength x width)

All struts fit within the geometry

Tie Loads = horizontal component of strut load

1	126.6
2	87.4
3	30.3

Total 244.3 Kip Tensile force at midspan

$A_s = 5.43$ in²

$n = 6.87$ #8

$A_s = 5.53$ in²

DESIGN

Use 7- #8 at 12 in each way Hook bars at end for anchorage

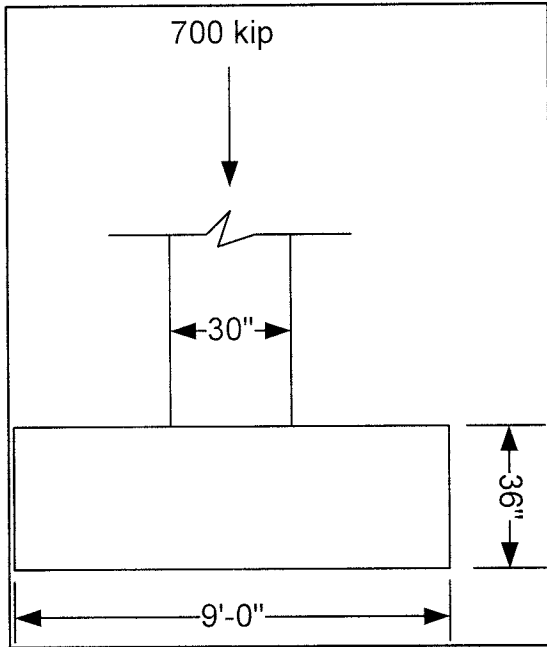
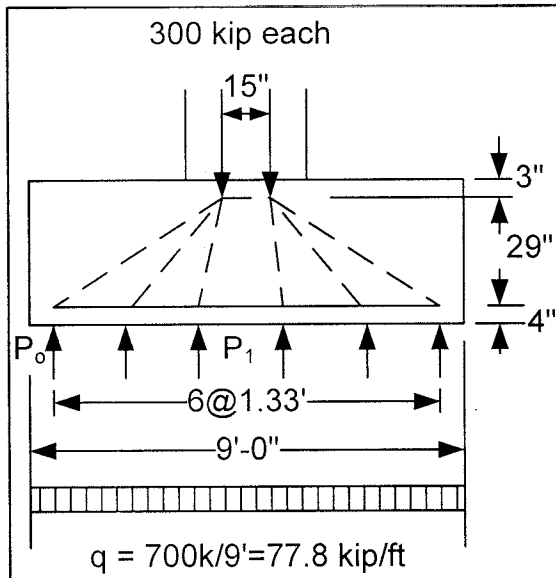

Figure P10.5



Strut-and-tie model

Problem 10.6 Redesign the footing in problem 10.5 using traditional flexure and shear methods as described in Chapter 16. Compare your solution to Problem 10.5 and comment on your results.

$$f_c := 4000\text{psi} \quad f_y := 60000\text{psi}$$

$$q_u := 8640 \frac{\text{lb}}{\text{ft}^2} \quad w_c := 150 \cdot \frac{\text{lb}}{\text{ft}^3}$$

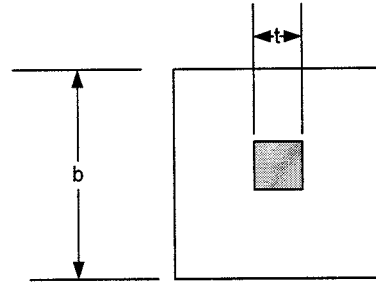

$$P_u := 750 \cdot \text{kip} \quad b := 9\text{ft} \quad h := 36\text{in}$$

$$\phi_s := 0.75 \quad \phi_f := 0.90 \quad \phi_b := 0.65$$

$$t := 30 \cdot \text{in}$$

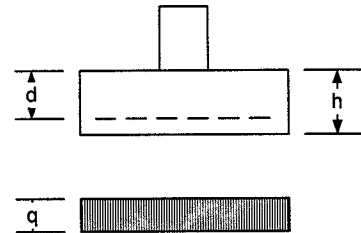

METHODOLOGY

1. Soil bearing is provided so no check of WSD is needed and step 1 is omitted.
2. Check punching shear. This check often sets the thickness of the footing.
3. Check slab shear.
4. Design flexural reinforcement.
5. Check bond and development length.
6. Check bearing stress under the column, especially if the column concrete strength is greater than the footing concrete strength.
7. Check temperature and minimum steel requirements and sketch final design.

2. Check Punching (two-way) Shear

$$d := h - 4.0\text{in} = 32\text{in}$$

4" difference between h and d reflects 3" cover and 1 to center of bars in two layers. H is less than the 36" originally used for weight so the bearing stress is OK.

$$b_o := 4 \cdot (d + t)$$

$$b_o = 248\text{in}$$

$$v_c := 4 \sqrt{f_c \cdot \text{psi}}$$

$$v_c = 253\text{psi}$$

$$A_v := b_o \cdot d$$

$$A_v = 7936\text{in}^2$$

$$\phi V_n := \phi_s \cdot v_c \cdot A_v$$

$$\phi V_n = 1506\text{kip}$$

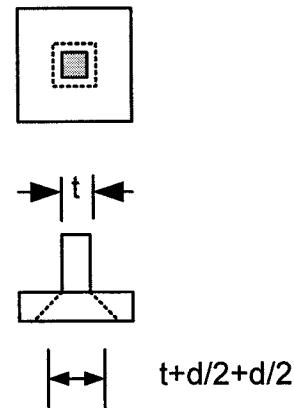

$\phi V_n > V_u = P_u$, therefore the design is OK.

Step 3 Check One-Way Shear along the face of the footing

$$w := \frac{b}{2} - d - \frac{t}{2} \quad w = 0.58 \text{ ft}$$

$$V_u := q_u \cdot w \cdot b \quad V_u = 45 \text{ kip}$$

$$\phi V_c := 2\phi_s \cdot \sqrt{f'_c} \cdot \text{psi} \cdot b \cdot d \quad \phi V_c = 328 \text{ kip}$$

Nominal shear capacity exceeds the ultimate load, therefore, one way shear is OK

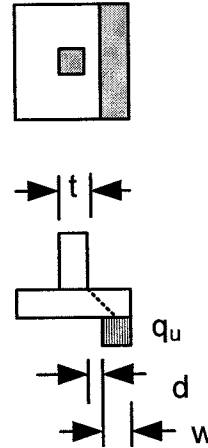

Step 4 Flexural Design

While the shear may be computed at a location d from the face of the column, the flexural design must be computed at the face of the column.

$$l := \frac{b}{2} - \frac{t}{2} = 3.25 \text{ ft} \quad M_u := \frac{q_u \cdot l^2}{2} = 548 \text{ in} \cdot \frac{\text{kip}}{\text{ft}}$$

try $a := 2 \cdot \text{in}$

$$A_s := \frac{M_u}{\phi_f \cdot f_y \cdot \left(d - \frac{a}{2}\right)} = 0.327 \frac{\text{in}^2}{\text{ft}}$$

$$A_{s8} := 0.79 \text{ in}^2$$

Spacing of #8 $s := \frac{A_{s8}}{A_s} \cdot 12 \cdot \frac{\text{in}}{\text{ft}} = 29.0 \text{ in}$

Try #8 @ 14 in. A_s provided = 0.68 in²/ft

Check "a"

$$\frac{0.68 \cdot \text{in}^2 \cdot f_y}{.85 \cdot f'_c \cdot 12 \cdot \text{in}} = 1.00 \text{ in} < a \text{ assumed, OK}$$

The estimate for "a" could be refined, but as will be seen later, the refinement is not necessary at this time.

Step 5 Check Bond and Development

The development length must be less than the portion of the slab extending beyond the face of the column.

#8 bottom bar from table A.10, $l_d/d_b = 38$ $d_b := 1.0 \text{ in}$ $\text{cover} := 3 \cdot \text{in}$

$$l_d := 38 \cdot d_b \quad l_d = 38 \text{ in} > \frac{b}{2} - \frac{t}{2} - \text{cover} = 36 \text{ in}$$

Therefore the development length requires hooks for anchorage

Step 6 Check Column Bearing Stress on Footing

If the column and footing do not have the same strength, an additional check is needed. It is not required for this problem.

Step 7 Check temperature and minimum reinforcement

$$A_{st} := 0.0018 \cdot h \qquad A_{st} = 0.778 \frac{1}{ft} \text{ in}^2$$

Temperature reinforcement is less than provided, therefore OK

$$A_{smin} := 0.0033d \qquad A_{smin} = 1.267 \frac{1}{ft} \text{ in}^2$$

Minimum reinforcement is greater than provided. Increase reinforcement to #8 @ 10 in $A_s=0.94 \text{ in}^2/\text{ft}$. Since A_s provided is greater than A_s required, the development length can be adjusted by 10/14 and the hooks are not required.

Final Detailing

Note: The footing is also influenced by the anchorage of the column reinforcement. The depth must be at least l_{dc} . Furthermore, if the column has bending, hooks may be required for the anchorage of the tensile steel.

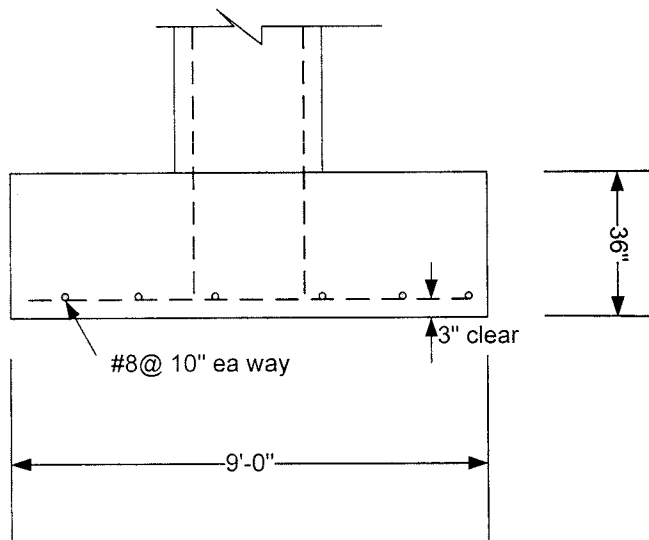

The strut-and-tie solution requires #8 at 12 in versus #8 at 14 inches prior to the correction for temperature. In addition, the strut-and-tie solution requires hooked bars where the traditional solution does not. Otherwise, the solutions are extremely similar.

11.1 INTERIOR JOINT

CARRY ALL BEAM AND GIRDER BARS THROUGH THE JOINT
THIS SATISFIES DEVELOPMENT REQUIREMENTS FOR BOTH TOP
AND BOTTOM BARS

CHECK CLEARANCES

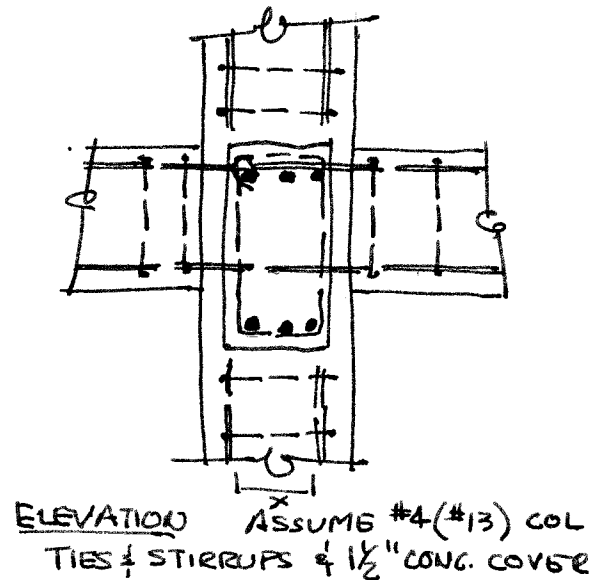
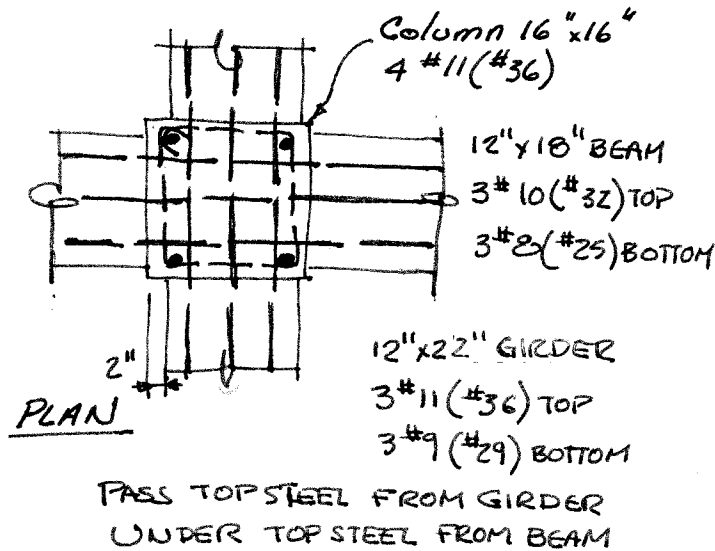

CHECK BAR SPACING

$$X = 16" - 3" \text{ COVER} - 2(1.41) - 1" \text{ STIRRUP} = 9.18 \text{ in}$$

$$\text{LESS } 3 \#11 (\#39) = \frac{4.23}{9.95}$$

$$\text{CLEAR SPACING} = 4.95/2 = 2.47 \text{ in} = 1.75 d_b \text{ OK}$$

CHECK CONFINEMENT

$$\text{BEAM WIDTH} = \text{GIRDER WIDTH} = 12 \text{ in}$$

$$3/4 \text{ COL WIDTH} = 3/4 \times 16 = 12 \text{ in} \text{ SO OK}$$

$$\text{ALSO EXPOSED CONCRETE} = (16 - 12)/2 = 2 \text{ in} < 4 \text{ in} \text{ OK}$$

∴ NO TRANSVERSE REINFORCEMENT IN JOINT

ALTHOUGH PART OF PRIMARY LATERAL LOAD SYSTEM, THE NET
MOMENT, WHEN COMBINED WITH DL+LL GRAVITY MOMENTS
WOULD BE $M_2 < M_1$, AND WOULD HAVE A SMALL SHEAR. BY
ACI 352 RECOMMENDATION $M_2 = M_1 = A_s f_y (d - a/2)$ RESULTING
IN NO SHEAR.

11.2 EXTERIOR JOINT

VERTICAL & HORIZONTAL CLEARANCE
OK AS CONFIRMED IN PROB 11.1

CHECK JOINT CLASSIFICATION FOR SHEAR.

$$\frac{3}{4} \times 16" = 12" = \text{GIRDER WIDTH}$$

$$\frac{3}{4} \times 22" \text{ depth} = 16.5", \text{ BEAM DEPTH} = 18" > 16.5"$$

SO JOINT IS "EXTERIOR" AND $\gamma = 20$

GIRDER MOMENTS BALANCE SO SHEAR IS
IN "BEAM" DIRECTION ONLY WITH EFFECTIVE
JOINT WIDTH $b_j = \frac{b_b + b_c}{2} = \frac{16 + 12}{2} = 14 \text{ in.}$

$$V_N = \gamma \sqrt{f_c'} b_j h = 20 \sqrt{4000} \frac{14 \times 18}{1000} = 319 \text{ k}$$

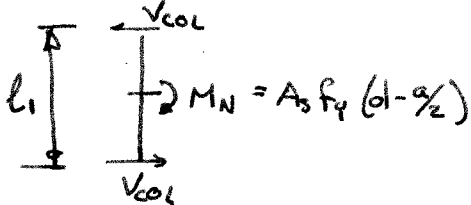

$$a = \frac{A_s f_y}{.85 f_c' b} = \frac{3(1.27)60}{.85(4)(12)} = 5.60 \text{ in}$$

$$M_n = 3(1.27)60(15.5 - \frac{5.6}{2}) \frac{1}{12} = 242 \text{ ft-kip}$$

COLUMN HEIGHT NOT GIVEN. ASSUME $l_1 = 12'$

$$V_{col} = \frac{M_n}{l_1} = \frac{242}{12} = 20.2 \text{ k} \quad T_u = A_s f_y = 3(1.27)60 = 229 \text{ k}$$

$$\text{IN JOINT } V_u = T_u - V_{col} = 229 - 20.2 = 208 \text{ k}$$

$$\phi V_n = 0.75(319) = 239 \text{ k} > V_u \quad \underline{\text{OK}}$$

CHECK CONFINEMENT IN "GIRDER" DIRECTION

$$\frac{3}{4}(16) = 12" = \text{GIRDER WIDTH, AND}$$

$$\text{EXPOSED COLUMN FACE} = (16 - 12)/2 = 2" < 4" \quad \text{— ALL OK}$$

BUT IN "BEAM" DIRECTION - MUST PROVIDE CONFINEMENT STEEL.
PROVIDE 2 LAYERS #4 (#13) TIES BETWEEN TOP & BOTTOM
BARS - (TENTATIVE - SEE FINAL BELOW).

CHECK BEAM BAR ANCHORAGE

$$\#10(\#32) \text{ BARS CRITICAL } l_{hb} = \frac{1200 d_b}{\sqrt{f_c'}} = \frac{1200(1.27)}{\sqrt{4000}} = 24.1"$$

USE MODIFICATION FACTOR = 0.7 DUE TO COLUMN SIDE COVER

$$l_h = 24.1(0.7) = 16.9" > \text{COLUMN.}$$

USE TIES ALONG FULL DEVELOPMENT LENGTH AT $s = 3d_b$
 $3(1.27) = 3.81" \text{ — USE } 3.5" \text{ THEN}$

$$l_h = 24.1(0.7)(0.8) = 13.5" \text{ also } \left. \begin{array}{l} > 8d_b = 10.2" \\ > 6" \end{array} \right\} \text{OK}$$

(CON'T.)

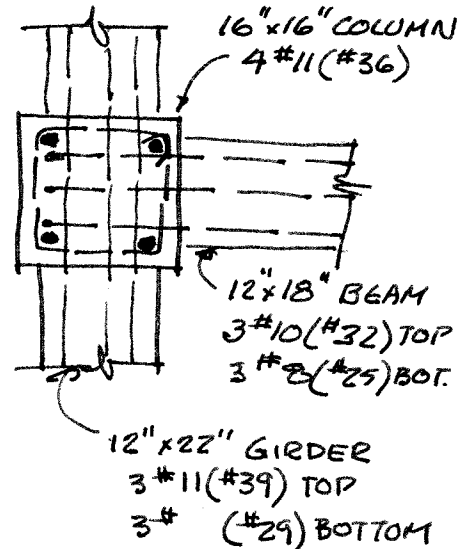

11.2 (CON'T.)

CHECK AVAILABLE SPACE = $16 - 1\frac{1}{2} \text{ COVER} - \frac{1}{2} \text{ tic} = 14" > 13.5" \text{ OK}$

TIES FOR $l_h = 13.5 \text{ in}$ $n = \frac{13.5}{3.5} = 3.8$ USE 4 #4 (#13) VERTICAL

TIES ALONG DEVELOPMENT LENGTH

BUT VERTICAL TIE WOULD INTERFERE WITH CONCRETE PLACEMENT. ACI CODE ALLOWS VERTICAL OR HORIZONTAL TIES, SO PLACE TIE HORIZONTALLY IN THE 11.59 IN CLEAR BETWEEN TOP & BOTTOM BARS

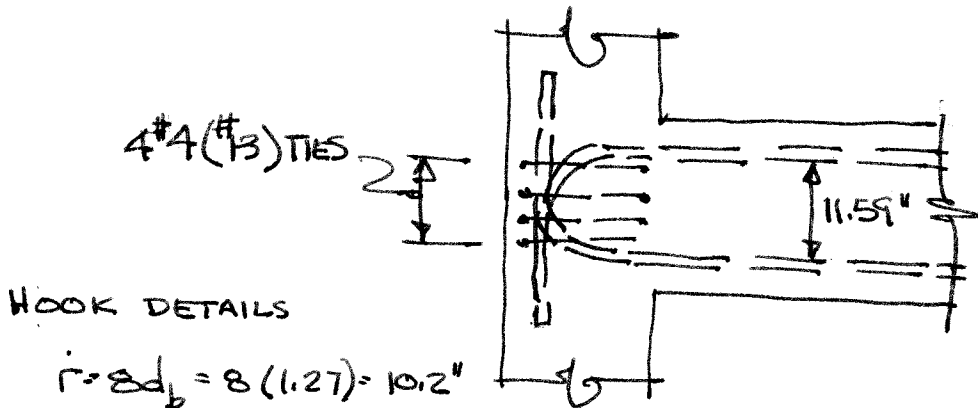

HOOK DETAILS

$$i = 8d_b = 8(1.27) = 10.2"$$

$$\text{EXT} = 12d_b = 12(1.27) = 15.2"$$

11.3 THERE ARE TWO SOLUTIONS - SHEAR FRICTION & STRUT & TIE
 SHEAR FRICTION SOLUTION

$f'_c = 6000 \text{ psi}$ $f_y = 60,000 \text{ psi}$ $b = 20$

$V_u = 1.2(45) + 1.6(36) = 111.6 \text{ k}$
 $N_{uc} = 0.2 V_u = 0.2(111.6) = 22.3 \text{ k}$

$V_n \leq \begin{cases} 0.2 f'_c b d = 1200 b d \\ 800 b d \leftarrow \end{cases}$

$V_u = \phi V_n$ $111.6 = 0.75(.80)(20)d$
 $d = 9.3''$

BUT ALSO

$d \geq \frac{1}{2}(9+y-1)$ $d \geq 8''$

and $h = 17''$ WITH $d = 16'' \leftarrow \text{USE}$

SHEAR FRICTION

$A_{vf} = \frac{V_u}{\phi \mu f_y} = \frac{111.6}{0.75(1.4)60} = 1.77 \text{ in}^2$

$M_u = V_u a + N_{uc}(h-d) = 111.6(6) + 22.3(1) = 692 \text{ in-k}$

$A_f = \frac{M_u}{\phi f_y (d - a/2)}$ ESTIMATE $a = 1''$

$= \frac{692}{0.75(60)(16-.5)} = 0.99 \text{ in}^2$ CHECK $a = \frac{0.99(60)}{.85(6)(20)} = 0.58 \text{ in}$

RESIZE WITH $a = 0.6$

$A_f = \frac{692}{0.75(60)(16-.6/2)} = 0.98 \text{ in}^2$ OK

$A_h = \frac{N_{uc}}{\phi f_y} = \frac{22.3}{0.75(60)} = 0.50 \text{ in}^2$

$A_s = A_f + A_h = 0.98 + 0.50 = 1.48 \text{ in}^2$

AND

$A_s = \frac{2}{3} A_{vf} + A_h = \frac{2}{3}(1.77) + 0.5 = 1.68 \text{ in}^2 \leftarrow \text{USE}$

CHECK $A_{s, \text{min}} = 0.04 \frac{f'_c}{f_y} b d = 0.04 \left(\frac{6}{60}\right) 20(16) = 1.28 \text{ in}^2$

USE 3 #7 (#22) = 1.80 in²

HOOP STEEL

$A_h = 0.5 A_f = 0.5(0.98) = 0.49 \text{ in}^2$

$A_h = \frac{1}{3} A_{vf} = \frac{1.77}{3} = 0.59 \text{ in}^2 \leftarrow \text{USE}$

USE 2 #4 (#13) \square $A_h = 2(2)(0.2) = 0.80 \text{ in}^2$
 hoop legs

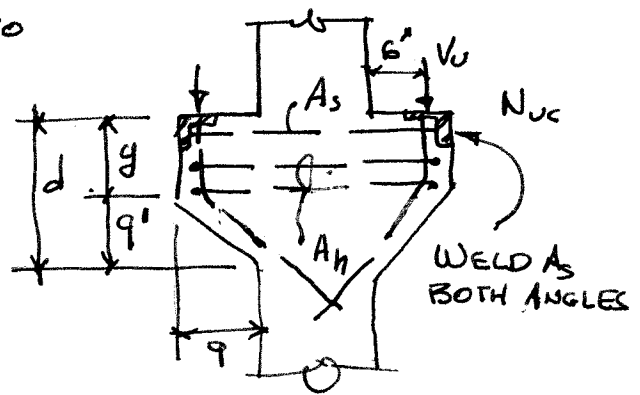

SHEAR-FRICTION SOLUTION

11.3 (CON'T.) - STRUT & TIE SOLUTION

$$\sum M_B = 0 = T_U h - V_U (6 + 2.5) - N_{UC} (17)$$

$$T_U = \frac{111.6(8.5) + 22.3(17)}{15} = 88.5 \text{ k}$$

$$\theta = \tan^{-1} \frac{8.5}{15} = 29.5^\circ$$

$$F_U = \frac{T_U}{\sin \theta} = \frac{88.5}{\sin(29.5)} = 180 \text{ k}$$

$$C_U = T_U = 88.5 \text{ k}$$

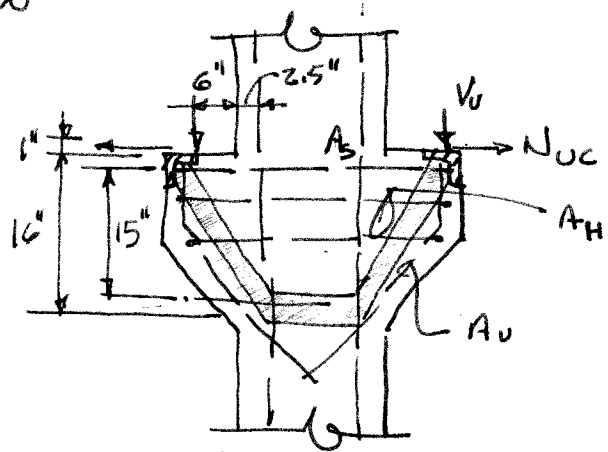

STRUT CAPACITY $\phi_s = 0.75$

$$f_{os} = \phi_s 0.85 f'_c = .75(.75).85(6) = 2.87 \text{ ksi}$$

$$W_s = \frac{F_U}{f_{os} b} = \frac{180}{2.87(20)} = 3.14 \text{ in}$$

COMPRESSION STRUT

$$W_c = \frac{C_U}{f_{os} b} = \frac{88.5}{2.87(20)} = 1.54 \text{ in}$$

CHECK TRUSS MODEL

$$h = 16 - 1 - \frac{1.54}{2} = 14.2 \text{ in} < 15 \text{ " REVISE}$$

$$\theta = \tan^{-1} \frac{8.5}{14} = 31.3^\circ$$

$$F_U = \frac{88.5}{\sin 31.3} = 170.3$$

$$W_s = \frac{170.3}{2.87(20)} = 2.97 \text{ " OK - FITS UNDER ANGLE}$$

$$W_c = \frac{88.5}{2.87(20)} = 1.54 \quad h = 16 - 1 - \frac{1.54}{2} = 14.2 > 15 \text{ " OK}$$

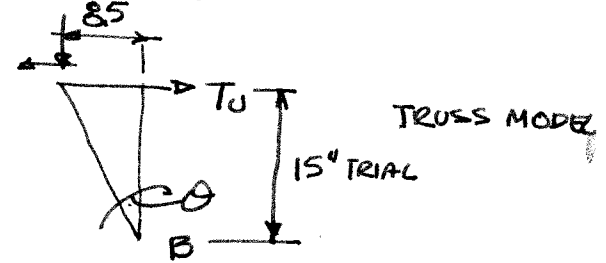

TENSION TIE

$$A_s = \frac{T_U}{\phi f_t} = \frac{88.5}{.75(60)} = 1.97 \text{ in}^2 \quad \text{USE } 3 \# 8 (\# 25) = 2.37 \text{ in}^2$$

SHEAR

$$A_v = 0.0025 b_s = .0025(20) \times \text{WIDTH OF BRACKET} = 0.45 \text{ in}^2 \quad 2 \# 5 (\# 16) = 0.62 \text{ in}^2$$

$$A_h = .0015 b_s = .0015(20)12 = 0.36 \text{ in}^2 \quad \# 4 (\# 13) \text{ AT } 12 \text{ in}$$

11.4 SOLUTION BY STRUT & TIE MODEL

$f'_c = 5000 \text{ psi}$, $f_y = 60,000 \text{ psi}$

$V_u = 1.2D + 1.6L$

$= 1.2(0.085)8 \left(\frac{30}{2}\right) + 1.6(0.090)8 \left(\frac{30}{2}\right)$
 $= 21.8 \text{ k}$

NODE CAPACITY $\beta_n = 0.80$

$f_{un} = \phi \beta_n (.85 f'_c) = .75(.8)(.85)5 = 2.55 \text{ ksi}$

BOTTLE STRUT CAPACITY $\beta_s = 0.75$

$f_{us} = \phi \beta_s (.85 f'_c) = 0.75(0.75)(.85)5 = 2.39 \text{ ksi}$

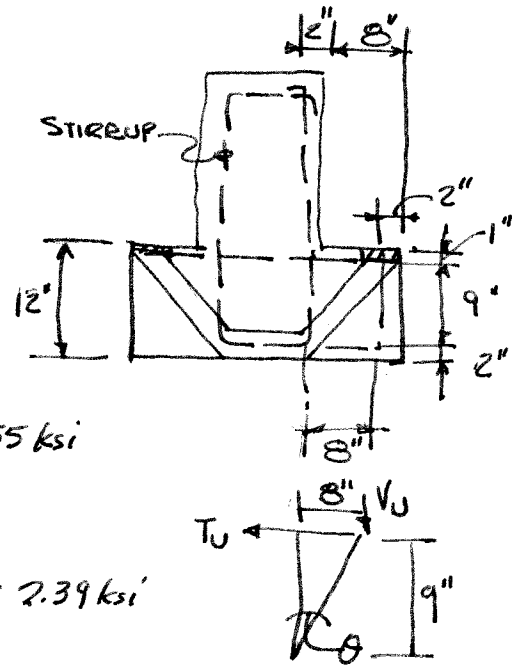

PRESSURE UNDER BEARING PLATE

$P = \frac{V_u}{A_b} = \frac{21.8}{4 \times 6} = 0.91 \text{ ksi} < f_{un}$ ok USE p for strut

$\theta = \text{TAN}^{-1} \frac{8}{9} = 41.6^\circ$

$F_u = \frac{V_u}{\cos \theta} = \frac{21.8}{\cos 41.6} = 29.2 \text{ k}$

STRUT WIDTH = $\frac{F_u}{p b} = \frac{29.2}{.91(6)} = 5.3''$

$T_u = C_u = F_u \sin \theta = 29.2 \sin 41.6 = 19.4 \text{ k}$

$w_c = \frac{19.4}{0.91(6)} = 3.5 \text{ in}$

$h_{AVAIL} = 12 - 1 - 3.5/2 = 9.2 \text{ in} > 9''$ Assumed ok

Assume $b = 6''$
WIDTH OF PLATE

TENSION TIE

$A_s = \frac{T_u}{\phi f_y} = \frac{19.4}{0.5(60)} = 0.43 \text{ in}^2$ USE 2#5 (#16) $A_s = 0.62 \text{ in}^2$

STIRRUT

$A_v = \frac{V_u}{\phi f_y} = \frac{21.8}{0.75(60)} = 0.48 \text{ in}^2$ USE 2#5 (#16) AT EA. PLATE
 $A_v = 0.62 \text{ in}^2$

ANCHOR STUDS ON PLATE - BY SHEAR FRICTION, $f_f = 90 \text{ ksi}$

$A_{sv} = \frac{C_u}{\phi \mu f} = \frac{19.4}{0.75(0.70)60} = 0.74 \text{ in}^2$

USE 4 #4 (#13) HEADED STUDS X 5" LONG (TO GO THRU STRUT)

12.1

SLAB; SPAN = 12'

$$h_{min} (\text{Table 13.1}) = \frac{l}{24} = \frac{12 \times 12}{24} = 6''$$

$$w_s = 150 \times \frac{6}{12} = 75 \text{ lb/ft}^2$$

$$w_u = 1.2(75 + 10) + 1.6 \times 250 = 502 \text{ lb/ft}^2$$

USING ACI COEF (TABLE 12.1)

$$l_n = 11'$$

$$M_u^- = \frac{w_u l_n^2}{10} = \frac{0.502 \times 11^2}{10} = 6.07 \text{ KIPS}$$

CHECK ρ USING TABLE A.9

$$\text{FOR } d = 5'' \text{ AND } \rho = 0.006, \phi M_n = 7.7 \text{ KIPS}$$

SLAB IS OK -

BEAMS + GIRDERS

USE SAME DEPTH FOR BOTH

USE $\frac{3}{4}$ in./ft FOR GIRDER

$$h = \frac{3}{4} \times 36 = 27'' - \text{WE WILL}$$

TRY $h_{max} = 30''$ HERE, BUT FOR A HIGH RISE BUILDING, WE WOULD USE A VALUE OF 27'' OR LESS TO LIMIT TOTAL BUILDING HEIGHT -

BEAMS: SPAN = 27'

$$h_{min} = \frac{l}{18.5} = \frac{27 \times 12}{18.5} = 17.5'' \text{ OK}$$

$$\text{TRY } b = 14'', h = 30'', d = 26''$$

$$w_d = 85 \times 12 + (30 - 6) \times 14 \times \frac{150}{144} = 1370 \text{ lb/ft} = 1.37 \text{ KIPS/ft}$$

$$w_r = 250 \times 12 = 3000 \text{ lb/ft} = 3.0 \text{ KIPS/ft}$$

$$w_u = 1.2 \times 1.37 + 1.6 \times 3.0 = 6.44 \text{ KIPS/ft}$$

$$M_u^- = \frac{w_u l^2}{10} = \frac{6.44 \times 26^2}{10} = 435 \text{ KIPS}$$

USING TABLE A.5, FOR $\rho = 0.012$,
 $R = 644$

$$\phi M_n = R b d^2 = \frac{644 \times 14 \times 26^2}{12000} = 508 \text{ KIPS}$$

CUT b TO 12'', $\phi M_n = 435 \text{ KIPS}$ EXACTLY

$$w_d = 85 \times 12 + (30 - 6) \times 12 \times \frac{150}{144} = 1320 \text{ lb/ft}$$

$$w_u = 1.2 \times 132 + 1.6 \times 3.0 = 6.38 \text{ KIPS/ft}$$

GIRDERS: SPAN = 36'

BEAM LOADS ON INTERIOR GIRDERS

$$= 27 \times 638 = 172 \text{ KIPS}$$

ASSUME $b = 36''$

$$w_g = 36(30 - 6) \times \frac{150}{144} \times \frac{1}{1500} = 0.9 \text{ KIPS/ft}$$

CALCULATE FEM

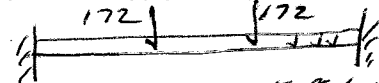

$$1.2 \times 0.9 = 1.08 \text{ KIPS/ft}$$

$$FEM = \frac{1.08 \times 36^2}{12} + \frac{2}{9} \times 172 \times 36 = 1493 \text{ KIPS}$$

V @ 1ST INTERIOR SUPPORT

$$= 1.15(172 + 1.08 \frac{36}{2}) = 220 \text{ KIPS}$$

M_u^- @ EXTERIOR FACE OF 1ST INTERIOR SUPPORT =

$$\frac{12}{10} \times FEM - \frac{V \times l}{2} \quad (\text{ASSUME } l = 27')$$

$$= 1.2 \times 1493 - \frac{220 \times 12}{2} = 1572 \text{ KIPS}$$

$$\frac{M_u}{\phi b d^2} = \frac{1572 \times 12000}{0.9 \times 36 \times 26^2} = 861$$

FROM TABLE A.5, $\rho < 0.017$ OK

EXTERIOR GIRDERS:

USE $b = 20''$, $h = 30''$

$$w_g = 0.5 \text{ KIPS/ft}, 1.2 w_g = 0.6 \text{ KIPS/ft}$$

$$\text{BEAM LOADS} = \frac{172}{2} = 86 \text{ KIPS}$$

$$FEM = \frac{0.6 \times 36^2}{12} + \frac{2}{9} \times 86 \times 36 = 753 \text{ KIPS}$$

$$V = 1.15(86 + 0.6 \times \frac{36}{2}) = 111 \text{ KIPS}$$

$$M_u = 1.2 \times 753 - \frac{111 \times 12}{2} = 793 \text{ KIPS}$$

$$\frac{M_u}{\phi b d^2} = \frac{793 \times 12000}{0.9 \times 20 \times 26^2} = 782$$

$\rho < 0.015$ OK

12.1 CONTINUED

COLUMNS: STORY HEIGHT = 13.5'

$$\left. \begin{array}{l} \text{DEAD LOAD} \\ \text{FROM COLUMN} \end{array} \right\} \approx \frac{150}{144} = 1.04 \text{ psi/ft}$$

$$\text{FOR FULL HEIGHT, COLUMN LOAD} \\ = 4 \times 13.5 \times 1.04 = 56 \text{ psi}$$

THIS IS SMALL ENOUGH TO IGNORE - HOWEVER, FOR A HIGH RISE BUILDING, IT CAN BE SIGNIFICANT + SHOULD BE CONSIDERED -

INTERNAL COLUMN:

$$\text{ROOF LOADS: } w_d = 85 \text{ lb/ft}^2$$

$$w_r = 12 \text{ lb/ft}^2$$

$$w_u = 1.2 \times 85 + 1.6 \times 12 = 121 \text{ lb/ft}^2$$

$$P_{\text{ROOF}} = 0.21 \times 27 \times 36 = 118 \text{ KIPS}$$

$$P_{\text{FLOOR}} = 2 \left(172 + 1.08 \frac{36}{2} \right) + 172 \\ = 2 \times 191 + 172 = 554 \text{ KIPS}$$

$$P_{1\text{ST FLOOR}} = P_{\text{ROOF}} + 3 P_{\text{FLOOR}} \\ = 118 + 3 \times 554 = 1780 \text{ KIPS}$$

P_u FOR INTERIOR COLUMNS

BASED ON 1ST INTERIOR COLUMN -

INCREASE TRIBUTARY AREA BY 10% FOR HIGHER SHEAR AND INCREASE AXIAL LOAD BY 10% TO ACCOUNT FOR EFFECTS OF BENDING

$$P_u = 1.1 \times 1.1 \times 1780 = 2154 \text{ KIPS}$$

$$\rho_s = 0.02$$

USING $P_u = 0.80 \phi P_o$ + A SQUARE COLUMN

$$= 0.80 \times 0.65 \left[0.85 \times f'_c \times h^2 + 0.02 h^2 (f_y - 0.85 f'_c) \right]$$

$$\text{GIVES } h = 22.9" \text{ FOR } f'_c = 8 \text{ KSI}$$

$$+ h = 25.7" \text{ FOR } f'_c = 6 \text{ KSI}$$

USE $h = 25"$ + $f'_c = 6 \text{ KSI}$ FOR FIRST STORY -

EXTERNAL COLUMN -

USE $\frac{1}{2}$ OF AXIAL LOAD FOR INTERIOR COLUMN (WITHOUT INCREASES) X 1.5 FOR BENDING EFFECTS

$$P_u = \frac{1}{2} 1780 \times 1.5 = 1335 \text{ KIPS}$$

$$\text{FOR } f'_c = 6 \text{ KSI, } h = 20.2"$$

$$\text{USE } h = 20"$$

CHECK UPPER STORY

COLUMNS TO DETERMINE

WHEN $\rho \approx 0.01$, THEN REDUCE

f'_c -

SUMMARY: $f'_c = 4 \text{ KSI}$

$$\text{SLAB} = 6" \quad f_y = 60 \text{ KSI}$$

$$\text{BEAMS} = b = 12" \\ h = 30"$$

$$\text{INTERIOR GIRDERS} \\ b = 36" \\ h = 30"$$

$$\text{EXTERNAL GIRDERS} \\ b = 20" \\ h = 30"$$

$$\text{INTERIOR COLUMNS} \\ b = h = 25"$$

$$\text{EXTERNAL COLUMNS} \\ b = h = 20"$$

COLUMN f'_c - START WITH 6 KSI + REDUCE FOR UPPER STORES

12.2 MOMENT REDISTRIBUTION IN BEAMS

$$A_s^+ = 2.45 \text{ in}^2 \quad A_s^- = 2.88 \text{ in}^2$$

- a) DRAW ELASTIC MOMENT DIAGRAM TO SEE WHICH SECTION, IF ANY, WILL YIELD AND ROTATE. COMPUTE M_n FOR EACH SECTION AND COMPARE THIS TO THE ELASTIC MOMENT DIAGRAM.

FIND M_n ; $T=C \quad A_s f_y = .85 f_c' a b$

$$a = 4.23 \text{ in.}$$

$$M_n = A_s f_y (d - \frac{a}{2}) = 2.88 \times 60 (24 - \frac{4.23}{2}) = 315 \text{ FT-K}$$

FIND M_n^+ ; $a = 2.45 \times 60 / (.85 \times 4 \times 12) = 3.6 \text{ in.}$

$$M_n^+ = 272 \text{ FT-KIPS.}$$

HOW COMPARE THESE TO ELASTIC MOMENT DIA;

$$P = 63.3 / 90 = 70.3 \text{ KIPS.}$$

$$M_A = 3PL / 16 = 310 \text{ FT KIPS} \approx 315 \text{ OK}$$

$$M_B = 5PL / 32 = 264 \text{ FT KIPS} < 272 \text{ OK.}$$

NEITHER SECTION WILL FORM A PLASTIC HINGE AND REQUIRE ROTATION CAPACITY BECAUSE OF MOMENT REDISTRIBUTION.

- b) A_s^- REDUCED BY 12.5%

FIND NEW M_n ;

$$A_s^- = 2.88 (1 - 0.125) = 2.52 \text{ in}^2$$

$$a = 3.71 \text{ in.}$$

$$M_n = A_s f_y (d - \frac{a}{2}) = 279 \text{ FT KIPS.}$$

M_n^+ CAN THEN BE FOUND BY CONSTRUCTING A STATICALLY CONSISTANT MOMENT DIAGRAM.

$$PL/4 = 421.8 \text{ K}; \quad M_n = 421.8 - 140 = 281.8$$

$$\phi M_n / bd^2 = 491 \text{ PSI} \quad \rho \approx 0.0084$$

$$A_s^+ = \rho b d = 0.0084 \times 12 \times 24 = 2.56 \text{ in}^2$$

SO A_s^+ IS APPROX EQUAL TO A_s^+ .

ROTATION REQUIREMENT AT LEFT SUPPORT.

(MOMENT AREA METHOD)

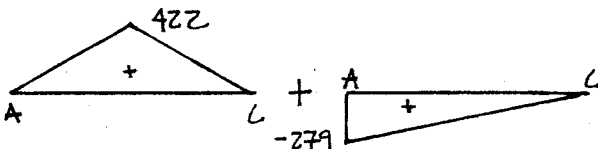

$$t_{CA} = \sum A \bar{x} \text{ ABOUT } C.$$

$$= 422 \times 12 \times 12 - 279 \times \frac{1}{2} \times 24 \times \frac{2}{3} \times 24 = 7200 / EI.$$

CALCULATE I_{CE} . $A_s \approx A_s^+ \approx 2.56 \text{ in}^2$

$$\rho = A_s / bd = 2.56 / (12 \times 24) = 0.00889.$$

$$C = 7.54 \text{ in.}$$

$$I_{CE} = \frac{1}{3} (12) \times 7.54^3 + 20.5 \times 16.5^2 = 7296 \text{ in}^4$$

SO, $t_{CA} = 0.474 \text{ in.}$ AND

$$\theta_A = t_{CA} / L = 0.00164 \text{ RADIANS.}$$

(CONJUGATE BEAM METHOD)

$$\sum M_C = 0 = \theta_A 24 + \frac{1}{EI} \left[\frac{1}{2} \times 279 \times 24 \times 16 - 422 \times 12 \times 12 \right]$$

$$\theta_A = 300 / EI = \left[\frac{300}{3.6 \times 10^3 \times 7296} \right] \times \left(\frac{12}{1} \right)^2 = 0.00164.$$

- d) 25% REDUCTION.

FIND NEW M_n

$$A_s^- = 2.88 (1 - 0.25) = 2.16 \text{ in}^2$$

$$a = 3.18 \text{ in} \quad M_n = 242 \text{ FT KIPS.}$$

$$M_n^+ = 422 - 121 = 301 \text{ FT KIPS.}$$

$$A_s^+ = 0. \quad \phi M_n / bd^2 = 470. \quad \rho \approx 0.0095$$

$$A_s^+ = 2.75 \text{ in}^2 \quad \text{THIS MUST BE ACCOUNTED}$$

FOR IN & RECALCULATED I_{CE} .

$$A_{s \text{ AVG}} = \frac{18(2.75) + 6(2.16)}{24} = 2.60 \text{ in}^2$$

$$\rho = 0.0090 \quad \text{AND } C = 7.54 \text{ in.}$$

USE SAME $I_{CE} = 7296 \text{ in}^4$.

$$t_{CA} = 14304 / EI = 0.94 \text{ in.}$$

$$\theta_A = 0.00327 \text{ RADIANS.}$$

ROTATION CAPACITIES

$$\phi_Y = \frac{\epsilon_Y}{4(1-k)} \quad \phi_Y' = \frac{M_n}{M_Y} \phi_Y \quad \phi_u = \frac{\epsilon_{cu}}{C}$$

$$\epsilon_p = (\phi_u - \phi_Y') l_p \quad l_p = 0.5d + 0.05z.$$

$$\epsilon_Y = \frac{f_y}{E} = 0.0021$$

12.2 (CONT)

FOR PART (A) THERE IS NO ROTATION REQ.
THE SECTION IS REINFORCED FOR THE
ELASTIC MOMENT DIAG, AND THEORETICALLY
BOTH THE SUPPORT AND CENTER SECTIONS
WOULD YIELD SIMULTANEOUSLY.

FOR PART (b) ROTATION REQMT = 0.0016 RAD.

$$\phi_Y = 0.0021 / 24(1 - 0.34) = 0.00013 / \text{IN}$$

$$M_Y = 2.52 \times 60 \times (24 - \frac{7.54}{3}) = 271 \text{ FT KIPS.}$$

$$\phi'_Y = [271 / 271] \times 0.00013 = 0.00013 / \text{IN.}$$

$$\epsilon_{cu} = 0.003 + 0.02 b \frac{V}{M} + 0.20 \rho''$$

$$V = 46.8 \text{ K} \quad M = 279 \text{ FT KIPS.}$$

$$\rho'' = \text{D TOTAL STIRUP LENGTH IS } 2$$

$$2 \times (24 - 2 - 1.5) + 2(12 - 3) = 59 \text{ IN.}$$

$$\#3 \square @ 9 \text{ IN. } A_s = 0.11 \text{ IN}^2$$

$$\rho'' = 0.11 \times 59 / 9 \times 12 \times 24 = 0.0025.$$

$$\epsilon_{cu} = 0.003 + 0.02 \times 12 \times (46.8 / 3348) +$$

$$+ 0.20 \times 0.0025$$

$$= 0.00685.$$

$$\text{HINGING LENGTH } l_p = 0.5 \times 24 + 0.05 \times 6 \times 12$$

$$= 15.6 \text{ IN.}$$

$$\phi_u = \epsilon_{cu} / c = 0.00685 / 4.4 = 0.0015.$$

$$\theta_p = (\phi_u - \phi'_Y) l_p$$

$$= (0.0015 - 0.00013) \times 15.6$$

$$\theta_p = 0.021 \text{ RAD.}$$

FOR PART (c) ROTATION REQMT IS 0.00327 RAD.

$$\phi_Y = 0.0021 / 24(1 - 0.24) = 0.00012 / \text{IN}$$

$$M_Y = 234 \text{ FT KIPS.}$$

$$\phi'_Y = 0.00012 \text{ RAD/IN}$$

$$\rho'' = \text{SAME } \epsilon_{cu} = 0.00688.$$

$$\phi_u = 0.00688 / 3.74 = 0.0018$$

$$l_p = 15.18 \text{ IN.}$$

$$\theta_p = 0.0255 \text{ RAD.}$$

ACI MOMENT REDISTRIBUTION

M - MAY BE

DECREASED BY 1000 ϵ_t % -

FOR PART (b) $A_s = 2.52 \text{ in}^2$

$$c = \frac{1}{0.85} \frac{2.52 \times 60}{0.85 \times 4 \times 12} = 4.36''$$

$$\epsilon_t = \frac{0.003(24 - 4.36)}{4.36} = 0.0135$$

→ % REDISTRIBUTION = 13.5%

$$M_{RED} = 315 \times 0.865 = 272 \text{ KIPS}$$

FOR PART (c) $A_s = 2.16 \text{ in}^2$

$$c = \frac{2.16}{2.52} \times 4.36 = 3.74''$$

$$\epsilon_t = \frac{0.003(24 - 3.74)}{3.74} = 0.016$$

→ % REDISTRIBUTION = 16%

$$M_{RED} = 315 \times 0.84 = 265 \text{ KIPS}$$

COMMENTS: ACI PROVIDES A LESS

TIME CONSUMING METHOD THAT YIELDS

GOOD RESULTS. IF, HOWEVER, MORE

REDUCTION IS REQUIRED THAN ALLOWED

BY ACI, THE THOROUGH ANALYSIS IS

NECESSARY.

12.3 MOMENT REDISTRIBUTION

a) $w = 0.9 \times 1.2 + 1.4 \times 1.6 = 3.32 \text{ KIPS/FT.}$

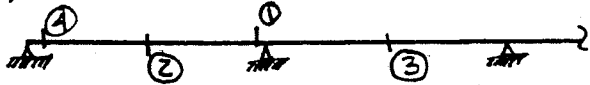

$$M_1^- = \frac{1}{10} \times 3.32 \times 25^2 = 207.5 \text{ FT-KIPS}$$

$$M_2^+ = \frac{1}{14} \times 3.32 \times 25^2 = 148.2 \text{ FT-KIPS}$$

$$M_3^+ = \frac{1}{16} \times 3.32 \times 25^2 = 129.7 \text{ FT-KIPS}$$

BASED ON $b_w = 12"$, $h = 24"$

b) ELASTIC FRAME.

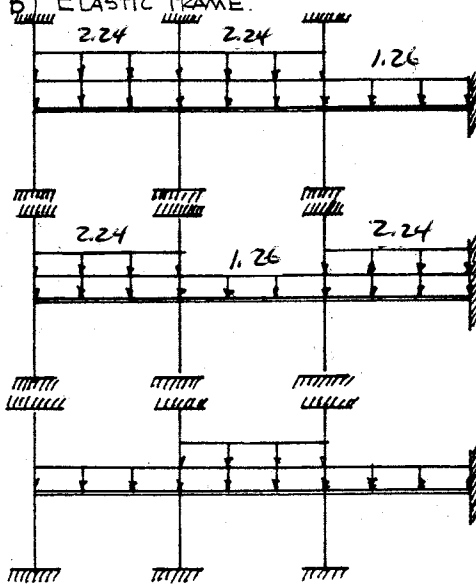

LOAD CASE 1

MAX M_1^-

LOAD CASE 2

MAX M_2^+

LOAD CASE 3

MAX M_3^+

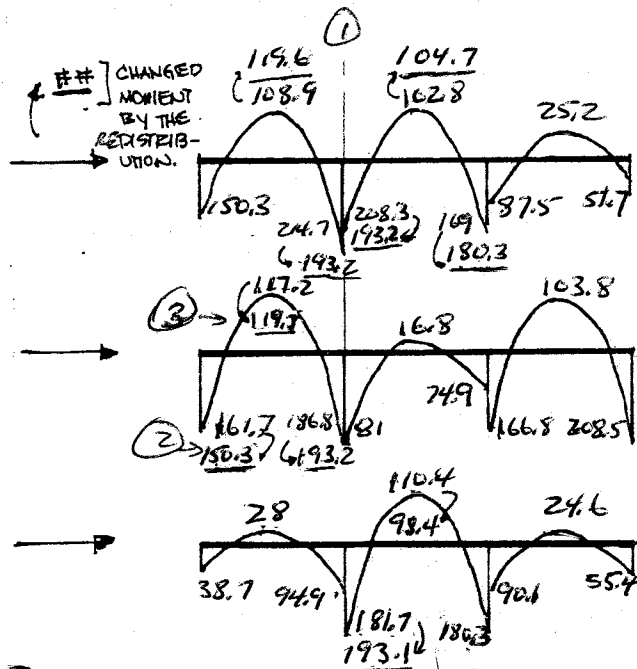

THE MINIMUM CHANGE IS 10% →

MOMENTS AT FACE OF SUPPORT - USE $V_u L/2 + DWLT$ CHANGE + VR MOM. -
 USE $V_u = 3.32 \times 25/2 = 41.5$, SAY 45 KIPS -

1) $M = 193 - (45 \times 1.5/2) = 159 \text{ FT}$

2) $M = 150 - (45 \times 1.5/2) = 116 \text{ FT-KIPS}$

SECTION DESIGN.

① $A_s = 1.89 \text{ in}^2$

② $A_s = 1.39 \text{ in}^2$

③ $A_s = 1.20 \text{ in}^2$ (T-SECTION)

12.4

RESULTS FROM ELASTIC FRAME ANALYSIS
BY COMPUTER:

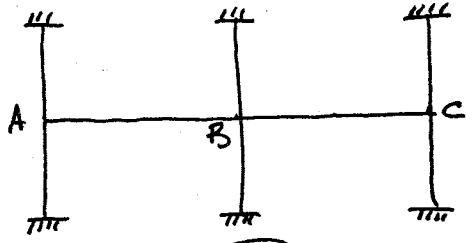

CASE A: DL+LL ON BOTH SPANS
 CASE B: DL+LL ON AB; DL ON BC
 CASE C: DL ON AB, DL+LL ON BC

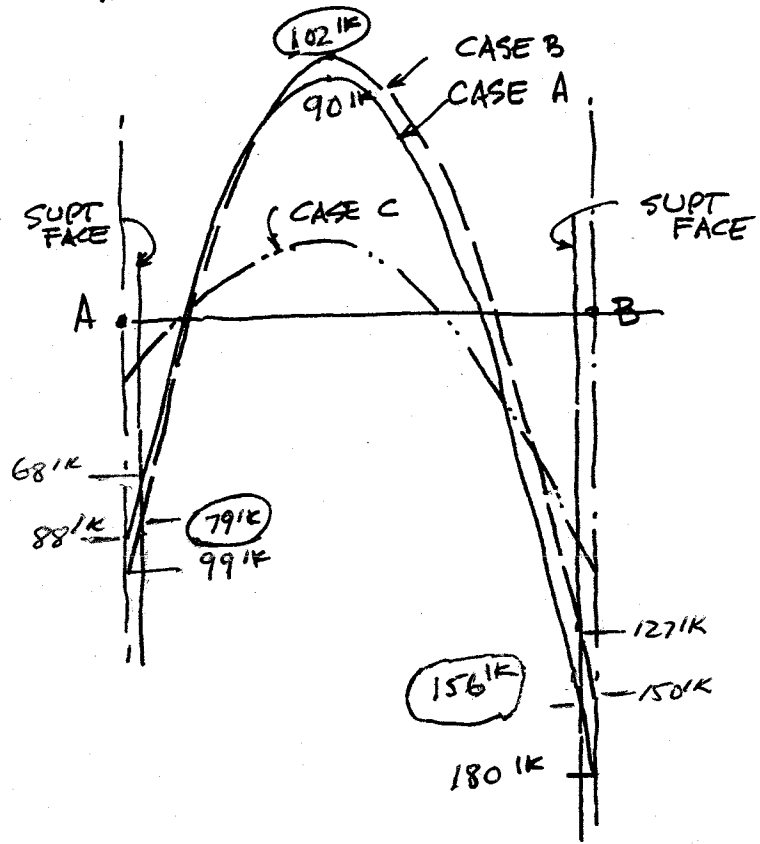

CASE A CONTROLS FOR M_{bmax}
 CASE B CONTROLS FOR M_{amax} , M_c
 DESIGN MOMENTS ARE CIRCLED

BASED ON M_{bmax} USE
 $b = 10"$
 $h = 22"$ $d = 19.5"$

A_s^- AT B: 3 No. 8 = 2.37 in^2
 A_s^- AT A: 2 No. 7 = 1.20
 A_s^+ AT AB: 3 No. 6 = 1.32

CUT OFFS ACCORDING TO FIG. 5.20a, BUT CARRY ALL A_s^+ INTO SUPPORTS.

REDISTRIBUTION ALLOWED:

MIDSPAN : $C = \frac{1}{0.85} \frac{1.32 \times 60}{0.85 \times 4 \times 10} = 2.74"$, $\epsilon_t = \frac{0.003(19.5 - 2.74)}{2.74} = 0.0184$
 MAX = 18.4%

INT SUPT: $C = \frac{1}{0.85} \frac{2.37 \times 60}{0.85 \times 4 \times 10} = 4.92"$, $\epsilon_t = \frac{0.003(19.5 - 4.92)}{4.92} = 0.0089$
 MAX = 8.9%

TAKE MAX REDUCTION AT B: ADJ $M_b^- = 156 \times 0.911 = 144 k$
 AND BY ADJUSTING M_a^- UPWARD KEEP M_{AB}^+ AT 90 k

NOW REDUCE M_{AB}^+ TO 90 k + ADJUST M_B^- UPWARD TO NEW $M_B^- = 151 k$; M_A^- UNCHANGED; THIS GIVES $M_{AB}^+ = 96 k$

12.4 (CON'T)

SO ADJUSTED DESIGN MOMENTS ARE:
 $M_A^- = 79 \text{ k}$ $M_{AB}^+ = 90 \text{ k}$ $M_B^- = 144 \text{ k}$

A_s^- AT B: 3 No. 7 = 1.80 in²
 A_s^- AT A: 2 No. 7 = 1.20 in²
 A_s^+ AT AB: 2 No. 7 = 1.20 in²

AGAIN USE CUTOFF POINTS FROM FIG. 5.15a BUT CARRY ALL A_s^+ INTO SUPPORTS

TOTAL WEIGHT OF STEEL WITHOUT ACI REDISTRIBUTION
= 402 LB FOR 2 SPANS

TOTAL WEIGHT WITH REDISTRIBUTION = 356 LB

STEEL REDUCTION = 11.4%

12.5

Slab: span = 10'

$$h_{min} (\text{Table 13.1}) = \frac{l}{24} = \frac{10 \times 12}{24} = 5''$$

$$w_s = 150 \times \frac{5}{12} = 62.5 \text{ lb/ft}^2$$

$$w_u = 1.2 \times 62.5 + 1.6 \times 150 = 315 \text{ lb/ft}$$

Using ACI COEF (Table 12.1)

$$+ l_n = 9'$$

$$M_u^- = \frac{w_u l_n^2}{10} = \frac{0.315 \times 9^2}{10} = 2.55 \text{ ft-kips/ft}$$

From Table A.9 for $d = 4'' + \rho = 0.003$,

$$\phi M_n = 2.5 \text{ ft-kips/ft}, \rho = 0.0031$$

will work -

Beams + Girders: span = 30'

Use same depth for both

Use 3/4 in./ft

$$h = \frac{3}{4} \times 30 = 22.5 \text{ in.}$$

$$h_{min} = l/18.5 = 30 \times 12/18.5 = 19.5 \text{ in.}$$

Beams: span = 29' - 9" = 29.75'

Try $b = 12 \text{ in.}, h = 24 \text{ in.}, d = 21.5 \text{ in.}$

$$w_d = 62.5 \times 10 + (24 - 5) \times 12 \times \frac{150}{144}$$

$$= 863 \text{ lb/ft} = 0.863 \text{ kips/ft}$$

$$w_l = 150 \times 10 = 1500 \text{ lb/ft} = 1.5 \text{ kips/ft}$$

$$w_u = 1.2 \times 0.863 + 1.6 \times 1.5 = 3.44 \text{ kips/ft}$$

$$M_u^- = \frac{w_u l_n^2}{10} = \frac{3.44 \times 29.75^2}{10} = 246 \text{ ft-kips}$$

Using Table A.5, for $\rho = 0.012$,

$$R = 644$$

$$\phi M_n = R b d^2 = \frac{644 \times 12 \times 21.5^2}{12000}$$

$$= 298 \text{ ft-kips}$$

OKAY -

Girders: span = 29.75'

Beam loads on interior girders

$$= 29.75 \times 3.44 = 102 \text{ kips}$$

Assume $b = 36 \text{ in.}$

$$w_g = 36(24 - 5) \times \frac{150}{144} \times \frac{1}{1000} = 0.71 \text{ kips/ft}$$

Calculate F_{EM}

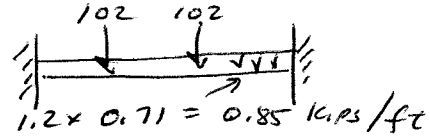

$$1.2 \times 0.71 = 0.85 \text{ kips/ft}$$

$$F_{EM} = \frac{0.85 \times 29.75^2}{12} + \frac{2}{9} \times 102 \times 29.75$$

$$= 737 \text{ ft-kips}$$

V @ 1st int support

$$= 1.15 \left(102 + 0.85 \frac{29.75}{2} \right) = 132 \text{ kips}$$

M_u^- @ exterior face of 1st interior support =

$$\frac{12}{10} \times F_{EM} - \frac{V a L}{2} \quad (\text{Assume } a = 1.5')$$

$$= 1.2 \times 737 - \frac{132 \times 1.5}{2} = 785 \text{ ft-kips}$$

$$\frac{M_u}{\phi b d^2} = \frac{785 \times 12000}{0.9 \times 36 \times 21.5^2} = 629$$

From Table A.5, $\rho \approx 0.012$

For exterior girders, use

$$b = 24 \text{ in.}$$

$$w_g = 0.47 \text{ kips/ft}, 1.2 w_g = 0.56 \text{ kips/ft}$$

$$\text{Beam loads} = \frac{102}{2} = 56 \text{ kips}$$

$$F_{EM} = \frac{0.56 \times 29.75^2}{12} + \frac{2}{9} \times 56 \times 29.75$$

$$= 412 \text{ ft-kips}$$

$$V = 1.15 \left(56 + 0.56 \times \frac{29.75}{2} \right) = 64 \text{ kips}$$

$$M_u^- = 1.2 \times 412 - \frac{64 \times 1.5}{2} = 446 \text{ ft-kips}$$

$$\frac{M_u}{\phi b d^2} = \frac{446 \times 12000}{0.9 \times 24 \times 21.5^2} = 536$$

$\rho \approx 0.01$ - OK

Proceed with columns as shown in solution to 12.1 -

Instructor's Solutions Manual

to accompany

Design of Concrete Structures, 14e

Nilson/Darwin/Dolan

Chapters 13-15

The authors welcome feedback on the problem solutions and on the text in general. Please e-mail any comments to David Darwin at: daved@ku.edu

PROPRIETARY AND CONFIDENTIAL

This Manual is the proprietary property of The McGraw-Hill Companies, Inc. ("McGraw-Hill") and protected by copyright and other state and federal laws. By opening and using this Manual the user agrees to the following restrictions, and if the recipient does not agree to these restrictions, the Manual should be promptly returned unopened to McGraw-Hill: This Manual is being provided only to authorized professors and instructors for use in preparing for the classes using the affiliated textbook. No other use or distribution of this Manual is permitted. This Manual may not be sold and may not be distributed to or used by any student or other third party. No part of this Manual may be reproduced, displayed or distributed in any form or by any means, electronic or otherwise, without the prior written permission of the McGraw-Hill.

13.1

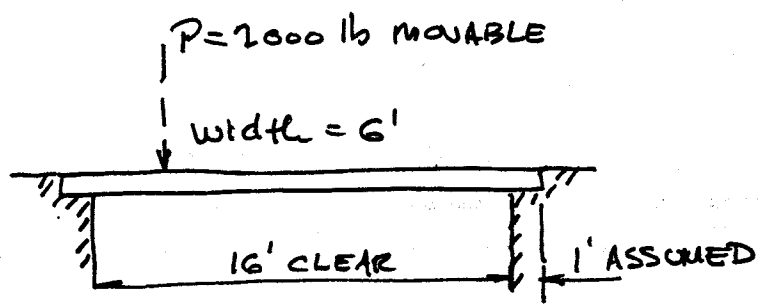

$f'_c = 4000$ psi
 $f_y = 60000$ psi
TAKE $l = 16 + 1 = 17'$

$w_d = 100 \text{ psf} \times 6 = 600 \text{ lb/ft}$
 $w_o = \frac{10}{12} \times 150 \times 6 = 750 \text{ lb/ft}$ (ASSUME $h = \frac{l}{20} = \frac{17}{20} = .85'$)
 $w_u = 20 \text{ lb} \times 6 = 120 \text{ lb/ft}$ (SAY 10")
 CURB WT NEGLIGIBLE (THEN $d = 9''$)

$w_u = 1.2(750 + 120) + 1.6 \times 600 = 2004 \text{ lb/ft}$

FOR MAX MOM PLACE P AT MIDSPAN:

$M_u = \frac{w_u l^2}{8} + \frac{Pl}{4} = \frac{2004 \times 17^2}{8} + \frac{2000 \times 17}{4} = 80.9 \text{ ft-k}$

$R = \frac{M_u}{\phi b d^2} = \frac{80.9 \times 12000}{.90 \times 72 \times 9^2} = 185$

FROM TABLE A5.2 NEED $\rho = .0032$
 $A_s = .0032 \times 72 \times 9 = 2.07 \text{ in}^2$ USE 7 No. 5 = 2.17 in^2
 FOR SIMPLICITY OF CONSTRUCTION CARRY ALL BARS INTO SUPPORTS (12 - 2) = 10"

CHECK SHEAR AT FACE OF SUPPORT WITH P IMMEDIATELY ADJACENT TO SUPT FACE

$V_u = \frac{w_u l}{2} + P = \frac{2004 \times 16}{2} + 2000 = 18.0 \text{ k}$

$\phi V_c = .85 \times 2 \sqrt{4000} \times \frac{72 \times 9}{1000} = 69.7 \text{ k} > V_u$ OKAY (No. 16)

LATERAL STEEL:
 $A_L = .0018 \times 12 \times 10 = .216 \text{ in}^2/\text{ft}$
 USE No. 5 AT 16" = .23

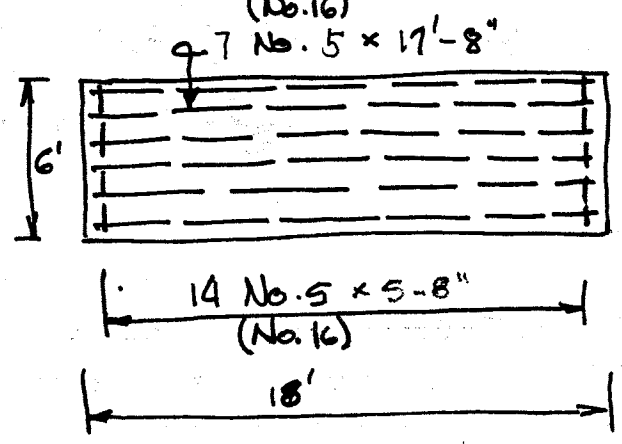

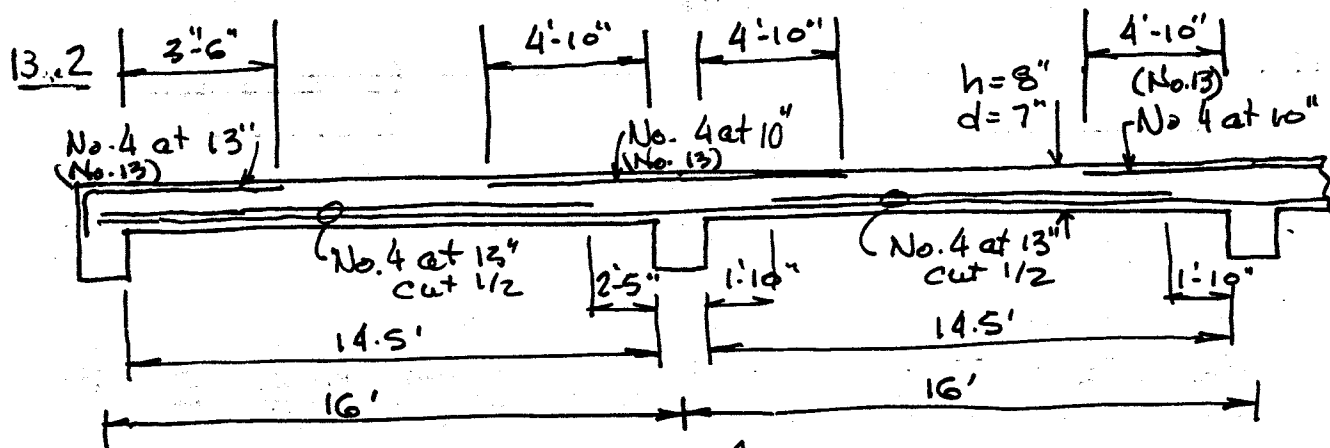

FROM TABLE G.2: $h = \frac{l}{24} = \frac{16 \times 12}{24} = 8''$ $w_o = 100 \text{ psf}$
 $\therefore d = 7''$

$w_u = 1.2(100 + 10 + 10) + 1.6 \times 125 = 344 \text{ psf}$

MOMENTS: (TABLE 11.1)

A:	$\frac{1}{24} \times \left(\frac{344 \times 14.5^2}{1000} \right) = 3.01 \text{ ft-k}$
AB:	$\frac{1}{14} \times \left(\frac{344 \times 14.5^2}{1000} \right) = 5.17$
B:	$\frac{1}{10} \times \left(\frac{344 \times 14.5^2}{1000} \right) = 7.23$
BC:	$\frac{1}{16} \times \left(\frac{344 \times 14.5^2}{1000} \right) = 4.52$
C:	$\frac{1}{17} \times \left(\frac{344 \times 14.5^2}{1000} \right) = 6.58$

$R_a = \frac{M_u}{\phi b d^2} = \frac{3.01 \times 12000}{.9 \times 12 \times 49} = 68$	$\rho = 0.0012$	$A_s = .18 \text{ in}^2/\text{ft}$	No. 4 AT 13"
$R_{ab} = 117$	$\rho = 0.0020$	$A_s = .18$	No. 4 AT 13"
$R_b = 164$	$\rho = 0.0028$	$A_s = .24$	No. 4 AT 10"
$R_{bc} = 102$	$\rho = 0.0017$	$A_s = .18$	No. 4 AT 13"
$R_c = 149$	$\rho = 0.0026$	$A_s = .22$	No. 4 AT 10"

CHECK $S_{min} = \frac{.0018 \times 12 \times 8}{12 \times 7} = .0021$ CONTROLS WHERE * ABOVE
 CHECK $S_{max} = 3h = 3 \times 8 = 24''$ OK

USE BAR CUTOFFS FROM FIG. 5.15; RESULTS ABOVE

MAX $V_u = 1.15 \frac{w_u l_n}{2} = \frac{1.15 \times 344 \times 14.5}{2 \times 1000} = 2.87 \text{ k}$

$\phi V_c = .85 \times 2 \sqrt{4000} \times 12 \times 7 \times \frac{1}{1000} = 9.03 \text{ k} > V_u$ OK
 (No. 13)

A_t IN DIRECTION \perp SPAN; USE No. 4 AT 13"
 PLACE ON TOP OF BOTTOM FLEX STEEL.

13.3 COMPUTE Δ_d FOR END SPAN (> INTERIOR!)
 COMPUTE FOR LOADING CORRESPONDING TO
 MAX $M^+ = \frac{1}{4} w l_u^2$. ASSUME BOTH END MOMENTS
 ARE EQUAL; USE STATICALLY CONSISTENT VALUE:
 DEAD LOAD = 100 + 10 + 10 = 120 PSF

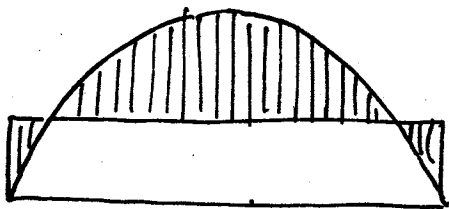

$$\frac{1}{4} \times 120 \times 14.5^2 = 1802 \text{ ft}\cdot\text{lb}$$

$$\frac{1}{8} \times 120 \times 14.5^2 = 3154 \text{ ft}\cdot\text{lb}$$

$$3154 - 1802 = 1352 \text{ ft}\cdot\text{lb}$$

$$f_r = 7.5 \sqrt{f'_c} = 7.5 \sqrt{3000} = 411 \text{ psi}$$

$$I_g = \frac{1}{12} \times 12 \times 8^3 = 512 \text{ in}^4$$

$$M_{cr} = f_r \frac{I_g}{\delta t} = 411 \times \frac{512}{48} = 4384 \text{ ft}\cdot\text{lb} > 1802 \text{ SO SLAB IS UNCRACKED AND}$$

NOW BY MOMENT-AREA:

$$I_e = I_g = 512 \text{ in}^4$$

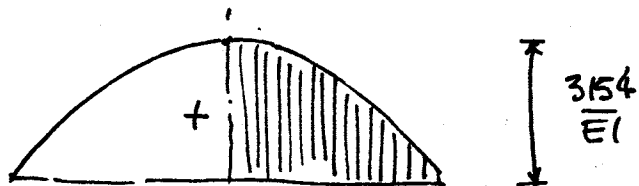

$$EI = 3.12 \times 10^6 \times 512$$

$$= 1597 \times 10^6 \text{ in}^2\cdot\text{lb}$$



$$\text{IMMEDIATE } \Delta_d = \frac{1}{EI} \left(3154 \times \frac{14.5}{2} \times \frac{2}{3} \times \frac{14.5}{2} \times \frac{5}{8} - 1352 \times \frac{14.5}{2} \times \frac{14.5}{4} \right)$$

$$= \frac{33544 \times 1728}{1597 \times 10^6} = \underline{\underline{.036}}$$

$$\text{LONG TERM COMPONENT } \Delta_d = .036 \times 2 = \underline{\underline{.072}}$$

$$\text{NOW FOR DEAD + LIVE LOAD} = 120 + 125 = 245 \text{ psf!}$$

13.3 (CON'T)

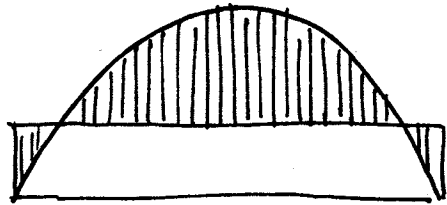

$$\frac{1}{14} \times 245 \times 14.5^2 = 3679 \text{ ft-lb}$$

$$5 \frac{1}{8} \times 245 \times 14.5^2 = 6439 \text{ ft-lb}$$

$$6439 - 3679 = 2760 \text{ ft-lb}$$

AND $3679 < M_{cr} = 4384 \text{ ft-lb}$ SO SLAB IS STILL UNCRACKED!

THEN $\Delta_e = .036 \times \frac{125}{120} = \underline{\underline{.038"}}$

TIME VARIATION OF λ :

\therefore PART OF TOTAL Δ OCCURRING AFTER EQUIPMENT IS INSTALLED:

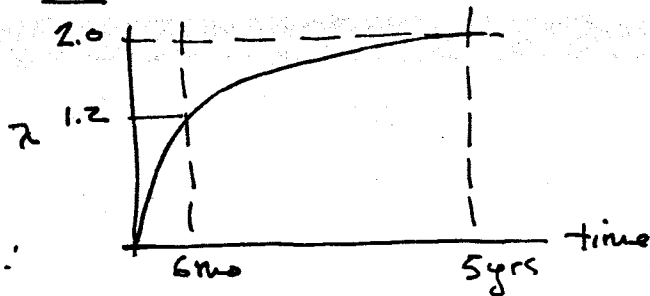

$$\Delta = \Delta_{d, \text{immed.}} \times 0.8 + \Delta_e = .036 \times 0.8 + .032 = .061"$$

ACI LIMIT VALUE (TABLE 6.3) = $\frac{l}{480} = \frac{145 \times 12}{480} = .363" > .061"$
SO SLAB IS OK

BUT NOTE THAT, BECAUSE ρ VALUES ARE VERY LOW FOR 8" SLAB, AND Δ IS ONLY 17% OF ALLOWED VALUE, A BETTER DESIGN COULD USE A THINNER SLAB! ACI SPAN DEPTH LIMITS LED TO VERY CONSERVATIVE DESIGN HERE.

13.4 $f'_c = 5000 \text{ psi}$ $f_y = 60,000 \text{ psi}$
 $w_L = 125 \text{ psf}$

THE SLAB SATISFIES ALL LIMITATIONS OF SECTION 13.6 AND THE ACI DIRECT DESIGN METHOD WILL BE USED

MINIMUM SLAB THICKNESS

$$\frac{26 \times 12}{33} = 9.45''$$

USE $t = 10''$

DEAD LOAD $w_D = \frac{10}{12} (150) = 125 \text{ psf}$

FACTORED LOAD

$$w_u = 1.2(125) + 1.6(125) = 350 \text{ psf}$$

FOR SHORT SPAN DIRECTION THE

TOTAL STATIC LOAD IS

$$M_0 = \frac{wL^2}{8} = \frac{0.350(26)(21-1.3)^2}{8} = 441 \text{ ft-kip}$$

NEGATIVE FACTORED MOMENT = $0.65M_0$

$$M_{u-} = 0.65(441) = 287 \text{ ft-kip}$$

POSITIVE FACTORED MOMENT = $0.35M_0$

$$M_{u+} = 0.35(441) = 154 \text{ ft-kip}$$

FOR LONG SPAN DIRECTION

$$M_0 = \frac{0.350(21)(26-1.3)^2}{8} = 561 \text{ ft-kip}$$

$$M_{u-} = 0.65(561) = 365 \text{ ft-kip}$$

$$M_{u+} = 0.35(561) = 196 \text{ ft-kip}$$

PLACE LONG-DIRECTION REINFORCEMENT CLOSER TO TOP & BOTTOM SO EFFECTIVE DEPTH $d = 9''$ AND SHORT DIRECTION $d = 8.25''$

MINIMUM REINFORCEMENT FOR SHRINKAGE AND TEMPERATURE

$$\rho = 0.0018$$

$$A_{s,min} = 0.0018(10)12 = 0.22 \text{ in}^2/\text{ft} \Rightarrow \#4(\#13) @ 20 \text{ in TOP \& BOTTOM}$$

BUT $s_{max} = 18 \text{ in}$ (ACI 7.12.2.2)

LONG SPAN 26'	STRIP	POSITION	M_u FT-KIP	b IN	d IN	ρ	A_s IN ²	REINFORCEMENT		
								SIZE	NUMBER	S
26'	COLUMN	NEG	274	126	9	.0062	7.03	No.5(16)	25	5
		POS	118			.0026	2.95	No.4(13)	16	8
	MIDDLE	NEG	91	9	.0020	2.27	"	11	11	
		POS	78		.0017	1.93	"	10	13	
	COLUMN	NEG	215	9	.0047	6.05	No.5(16)	26	8	
		POS	92		.0020	2.57	No.4(13)	13	12	
SHORT SPAN 21'	MIDDLE	NEG	72	156	8.25	.0015	1.93	"	10	16
		POS	62			.0013*	-	"	9	18

* A_s ESTABLISHED BY SHRINK & TEMP REQUIREMENTS

13.16 $f'_c = 5000 \text{ psi}$ $f_y = 60,000 \text{ psi}$
 $E_c = 57,000 \sqrt{f'_c} = 4.0 \times 10^6 \text{ psi}$
 $w_D = 125 \text{ psf}$ $w_L = 125 \text{ psf}$
 $h = 10''$

FACTORED LOAD $w_u = 1.2D + 1.6L$
 $= 1.2(125) + 1.6(125)$
 $= 350 \text{ psf}$

LONG DIRECTION $l_1 = 26' = 312''$

SLAB STIFFNESS $K_s = \frac{4E_c I_c}{l_1} = \frac{4E_c \times 252 \times 10^5}{12 \times 312} = 269 E_c$

COLUMN STIFFNESS $K_c = \frac{4E_c (16 \times 16^3) / 12}{144} = 152 E_c$

TORSIONAL MEMBER $y = 16''$ $x = 10''$

$C = (1 - 0.63 \frac{x}{y}) \frac{x^3 y}{3} = (1 - 0.63 \frac{10}{16}) \frac{10^3 (16)}{3} = 3233 \text{ in}^4$

TORSIONAL STIFFNESS

$K_T = \frac{9E_c C}{l_2 (1 - C_2/l_2)^3} = \frac{9E_c 3233}{252 (1 - 16/252)^3} = 141 E_c$

EQUIVALENT STIFFNESS OF COLUMN

$\frac{1}{K_{EC}} = \frac{1}{2K_c} + \frac{1}{2K_T} = \frac{1}{2(152)E_c} + \frac{1}{2(141)E_c}$

$K_{EC} = 146 E_c$

RATIO OF LL/DL = $\frac{1.6(125)}{1.2(125)} = 1.4 > 0.75$ PER CODE \therefore PATTERN LOADING REQD

CONSIDER SECOND (1ST INTERIOR) SPAN - 3 LOAD CASES

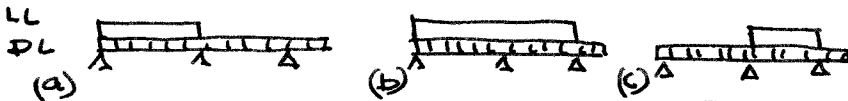

USING MOMENT DISTRIBUTION OR COMPUTER STRUCTURAL ANALYSIS SOFTWARE (SAP2000) FIND M & V FOR SLAB. FOR 2ND SPAN CASE (a) CONTROLS NEGATIVE M & CASE (c) CONTROLS MIDSPAN M₊.

$M_- = 403 \text{ k}$
 $M_+ = 202 \text{ k}$
 $V_0 = 98.2 \text{ k}$

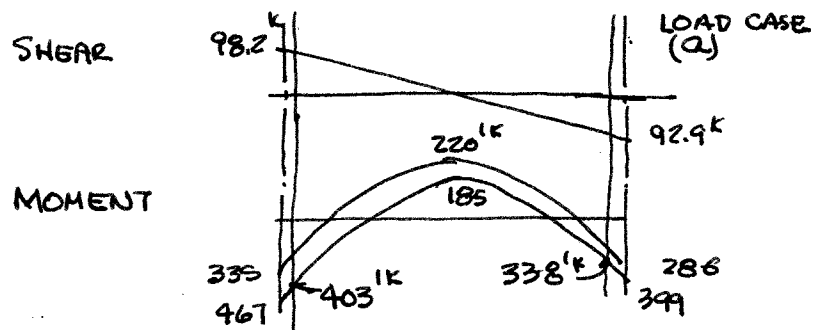

(CONT.)

13.6 (CON'T.)

SIMILARLY MOMENT & SHEAR IN THE SHORT DIRECTION

$$K_s = \frac{4E_c \cdot 312 \cdot 10^3 / 12}{252} = 413 E_c$$

$$K_c = 152 E_c \quad C = 3233 \text{ in}^4$$

$$K_T = \frac{9 E_c \cdot 3233}{312 \left(1 - \frac{16}{312}\right)^3} = 109 E_c$$

$$K_{EC} = 127 E_c$$

$$M_{U-} = 330 \text{ ft-kips}$$

$$M_{U+} = 181 \text{ ft-kips}$$

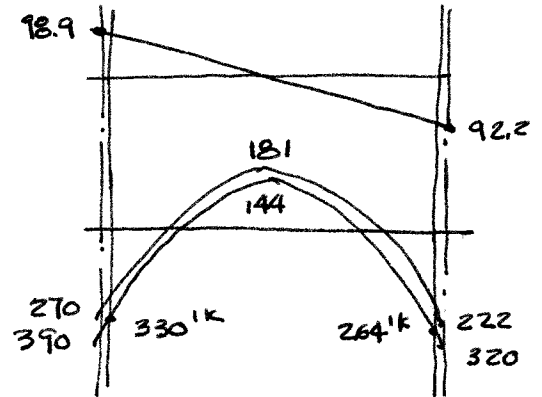

THE LATERAL DISTRIBUTION OF MOMENTS AND REINFORCEMENT DESIGN ARE SUMMARIZED IN THE FOLLOWING TABLES.

		EQUIVALENT FRAME	DIRECT DESIGN (PKDB 13.4)	RATIO
LONG DIRECTION	M ₋	403	365	1.10
	M ₊	202	196	1.03
SHORT DIRECTION	M ₋	330	287	1.15
	M ₊	181	154	1.18

IN THIS CASE THE EQUIVALENT FRAME IS MORE CONSERVATIVE.

		REINFORCEMENT								
	STRIP	POSITION	M _U FT-KIP	b in	d in	ρ	A _s in ²	SIZE	NUMBER	S
LONG DIRECTION 26'	COLUMN	NEG	302	126	9	.0069	7.83	No. 5 (16)	25	5
		POS	121			.0027	3.14	No. 4 (13)	16	8
	MIDDLE	NEG	101	156	8.25	.0022	2.55	"	13	10
		POS	81			.0018	2.09	"	11	12
SHORT DIRECTION 21' FT	COLUMN	NEG	248	156	8.25	.0054	6.95	No. (16)	23	6
		POS	109			.0023	2.96	No. 4 (13)	15	10
	MIDDLE	NEG	82	156	8.25	.0017	2.19	"	11	14
		POS	72			.0015	1.93	"	10	16

13.7 $l_1 = l_2 = 20 \text{ ft}$

$f'_c = 4000 \text{ psi}, f_y = 60,000 \text{ psi}$

$w_d = 100 \text{ psf}$

Assume $h = 8 \text{ in}$ Average $d = 6.5 \text{ in}$

$w_o = \frac{8}{12} 150 = 100 \text{ psf}$

$w_k = 1.2D + 1.6L = 1.2(100) + 1.6(100) = 280 \text{ psf}$

$V_o = w(l^2 - (d+b)^2) = 280 \left(20^2 - \left(\frac{16+6.5}{12} \right)^2 \right) \frac{1}{1000} = 111.0 \text{ K}$

$\phi V_c = \phi 4 b_o d \sqrt{f'_c} = 0.75(4)(16+6.5)(6.5) \frac{\sqrt{4000}}{1000} = 111.0 \text{ K}$

$\phi V_c = V_o \therefore \text{SHEAR OK}$

$\frac{l_n}{33} = \frac{240-16}{33} = 6.78 \text{ in} < 8'' \therefore \text{OK FOR DESIGN}$

$M_o = \frac{wL^2}{8} = \frac{.28(20)(20-16/12)^2}{8} = 244 \text{ FT-KIP}$

NEGATIVE FACTORED MOMENT = $0.65M_o = 0.65(244) = 159 \text{ FT KIP}$

POSITIVE FACTORED MOMENT = $0.35M_o = 0.35(244) = 85 \text{ FT KIP}$

MAXIMUM BAR SPACING = $18''$

TEMP SHRINKAGE = $0.0018(8)12 = 0.173 \text{ in}^2/\text{ft}$ No. 4(13) AT 13in

LOCATION		M_o FT-KIP	b	d in	ρ	A_{s2} in ²	BAR SIZE	No. of BARS	s (in)
COLUMN STRIP	NEG	119	{	}	.0055	4.29	No. 4(13)	22	5
	POS	51	120	6.5	.0023	1.79	"	9	13
MIDDLE STRIP	NEG	40	}	{	.0018*	1.40	"	9	13
	POS	34	}	{	.0015*	1.17	"	9	13

FINAL BARS & SPACING SET BY TEMP & SHRINKAGE

Problem 13.8

$$V_u := 107 \text{ kip} \quad f_c := 3000 \text{ psi} \quad f_y := 60000 \text{ psi} \quad f_{ys} := 51000 \text{ psi}$$

$$t := 7.5 \text{ in} \quad d := 6 \text{ in} \quad t_{col} := 10 \text{ in} \quad \phi_s := 0.75 \quad \lambda := 1.0$$

From Example 13.7 the basic perimeter shear is inadequate and strengthening is required.

$$b_o := 4 \cdot (t_{col} + d) = 64 \text{ in}$$

a) Design truss bar solution

$$V_{max} := 6 \sqrt{f_c \cdot \text{psi}} \cdot b_o \cdot d = 126.2 \text{ kip} \quad \text{This is greater than } V_u \text{ so proceed.}$$

$$V_c := 2 \cdot \sqrt{f_c \cdot \text{psi}} \cdot b_o \cdot d = 42.1 \text{ kip} \quad \alpha := 45 \text{ deg}$$

$$A_v := \frac{V_u - V_c}{\phi_s \cdot f_y \cdot \sin(\alpha)} = 2.04 \text{ in}^2$$

Use four bars, two in each direction. this provides 8 bars crossing the critical section.

$$A_{bar} := \frac{A_v}{8} = 0.26 \text{ in}^2 \quad \text{Use 4-No.5 (No. 16) bars}$$

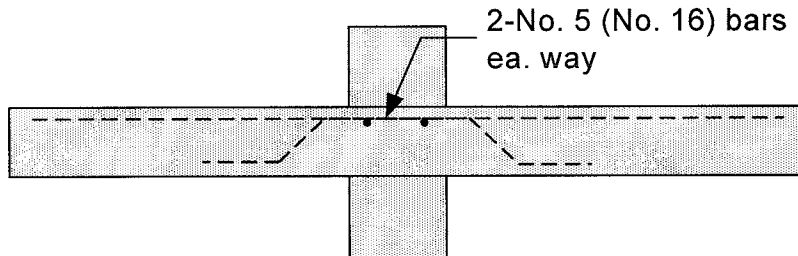

b) Design integral beam

The maximum allowable load by ACI 318 is $V_{max} = 126.2 \text{ kip}$ per above.

Try No. 3 (No. 10) stirrups. With two stirrup legs per stirrup and four arms on the beams, the total area of shear reinforcement is:

$$A_{vo} := 4 \cdot 2 \cdot 0.11 \text{ in}^2 = 0.88 \text{ in}^2 \quad \text{and the spacing is} \quad s := \frac{\phi_s \cdot A_{vo} \cdot f_y \cdot d}{V_u - \phi_s \cdot V_c} = 3.15 \text{ in}$$

The Code requires a maximum spacing of $d/2$, therefore a spacing of $s=3 \text{ in.}$ will be used.

The required perimeter is

$$b_{o1} := \frac{V_u}{\phi_s \cdot 2 \cdot \sqrt{f_c \cdot \text{psi}} \cdot d} = 217 \text{ in}$$

From the sketch below, it can be seen that the leg must extend 32 in from the column face and that 10 stirrups/leg are needed.

$$b_{\text{ofinal}} := 4 \cdot (32 \text{ in} \cdot \sqrt{2} + 10 \text{ in}) = 221 \text{ in}$$

c) design headed shear studs

The minimum height of the headed shear studs is 5.68 in per example 13.6. Use 6 in.

Try $s := 3 \text{ in}$ since the stud spacing must be $\leq d/2$

$$A_{vs} := \frac{(V_u - \phi_s \cdot V_c) \cdot s}{\phi_s \cdot f_{ys} \cdot d} = 0.986 \text{ in}^2$$

Use two lines of studs per rail giving 8 studs crossing a critical plane. thus:

$$A_{\text{stud}} := \frac{A_{vs}}{8} = 0.123 \text{ in}^2 \quad \text{No. 4 (No. 13) studs will be used. The layout is the same as for the integral beam and 10 x 2 studs will be used on each leg.}$$

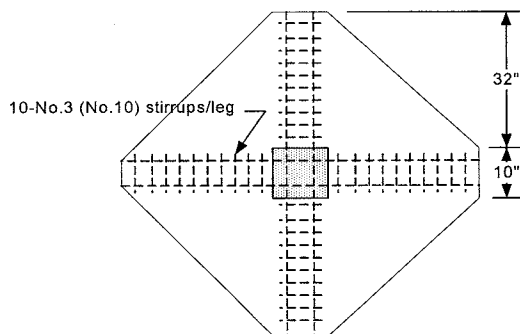

Internal Beam solution

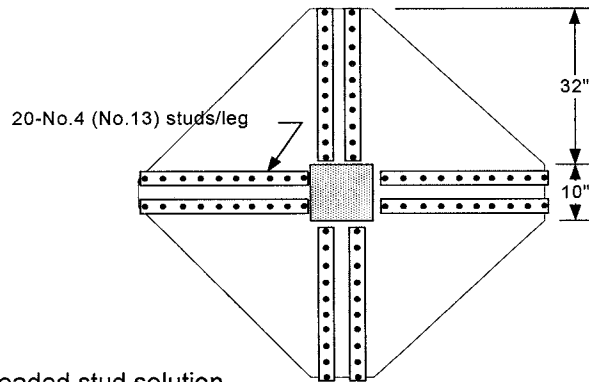

Headed stud solution

13.9 $h = 7.5 \text{ in}$ $d = 6 \text{ in}$ COLUMN = $18 \times 18 \text{ in}$
 $f'_c = 4000 \text{ psi}$ $V_u = 118,800 \text{ lb}$

ASSUME NEGATIVE REINFORCEMENT = No.5 (No.16) AT 5 in

$$\phi V_c = \phi 4 b_o d \sqrt{f'_c} = 0.75(4)[4(18+6)]6 \sqrt{4000} = 109,300 \text{ lb}$$

$$\phi V_c < V \quad \therefore \text{USE SHEARHEAD}$$

$$\text{REQ'D } b_o = \frac{V_u}{\phi d 4 \sqrt{f'_c}} = \frac{118,800}{6(0.75)4 \sqrt{4000}} = 104.4 \text{ in}$$

$$b_o = 4 \sqrt{2} \left(\frac{c_1}{2} + \frac{3}{4} \left(l_v - \frac{c_1}{2} \right) \right) = 104.4$$

$$c_1 = 18 \text{ in}$$

$$l_v = 21.6 - \text{USE } 22 \text{ in}$$

TRY I SECTION 54×7.7 , $f_y = 50 \text{ ksi}$
 MOMENT RESISTANCE = $176,000 \text{ in-lb}$
 $E_s I_y = 174 \times 10^6 \text{ in}^2 \text{-lb}$

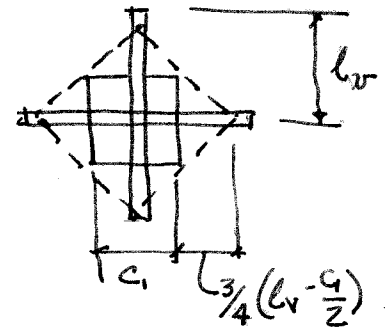

$$\#5 (\#16) \text{ AT } 5 \text{ in} \quad n A_s = 8(0.74) \frac{24}{12} = 11.84 \text{ in}^2$$

LOCATE NEUTRAL AXIS

$$\bar{y} = \frac{11.84(6) + 18.1(2.75) + 17.2 \bar{y}^2}{11.84 + 18.1 + 24 \bar{y}}$$

$$\bar{y} = 2.16 \text{ in}$$

$$I_c = \frac{1}{3} 24 (2.16)^3 + 11.84 (3.84)^2 + 6 \times 8 + 18.1 (0.59)^2$$

$$= 309.5 \text{ in}^4$$

$$E_c I_c = 3.6 \times 10^6 (309.5) = 1114 \times 10^6 \text{ in}^2 \text{-lb}$$

$$\alpha_v = \frac{174}{1114} = 0.16 > 0.15 \text{ OK}$$

$$M_p = \frac{V_u}{2 \phi n} \left[h_v + \alpha_v \left(l_v - \frac{c_1}{2} \right) \right] = \frac{118,800}{2(0.75)4} \left[4 + 0.16 \left(22 - \frac{18}{2} \right) \right]$$

$$= 100,300 \text{ in-lb} < 176,000 \text{ CAPACITY (OK)} \quad \text{I BEAM IS ADEQUATE}$$

USING A COLUMN CAPITAL $b_o = 104.4$, SIDE = $104.4/4 = 26.1 \text{ in}$
 THE FOLLOWING CAPITAL CAN BE USED

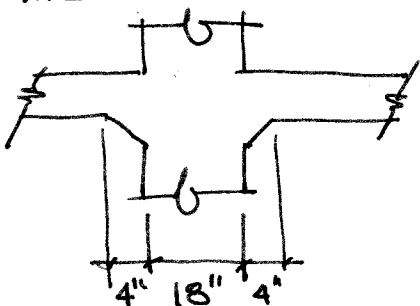

$$b_o = 4(18 + 4 + 4 + 6) = 128 \text{ in}$$

NOTE: AN EXTENSION AS SMALL AS 2" PROVIDES AN ACCEPTABLE b_o , BUT IS TOO SMALL TO FORM.

13.10 FLAT PLATE SHEAR.

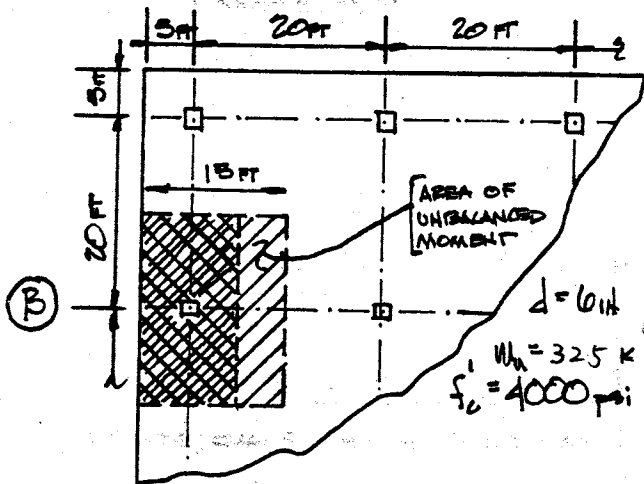

AT COLUMN B-1

$$V_u = 105 \text{ kips}$$

$$M_{\text{UNBALANCED}} = 120 \text{ ft-kips}$$

$$M_{ub} = 0.60 \times M_u = 72.0 \text{ ft-kips}$$

$$M_{ur} = 0.40 \times M_u = 48.0 \text{ ft-kips}$$

$$A_c = 2 \times 6 [24 + 24] = 576 \text{ in}^2$$

$$c_2 = c_r = 12 \text{ in. } c_1 + d = 24 \text{ in} = c_2 + d$$

$$J_c = \frac{2 \times 6}{12} (24)^3 + \frac{2}{12} (24) 6^3 + 2 \times 6 (24) (12)^2$$

$$= 56160 \text{ in}^4$$

SHEAR STRESSES

$$v_2 = \frac{105000}{576} - \frac{48000 \times 12 \times 12}{56160} =$$

$$= 182 - 123 = 59 \text{ psi}$$

$$v_r = 182 + 123 = 305 \text{ psi}$$

$$v_{\text{allowed}} = 4 \times .85 \sqrt{4000} = 215 \text{ psi}$$

AND $215 < 305$ SO NEED SOME EXTRA AGAINST SHEAR.

USE DROPPED PANEL AT EXTERIOR COLUMNS.

TRY $h = 9\frac{1}{2}$ in. $d = 8$ in.

$$c_1 + d = c_2 + d = 26 \text{ in.}$$

$$A_c = 2 \times 8 \times (26 + 26) = 832 \text{ in}^2$$

$$c_e = c_r = 13 \text{ in.}$$

$$J_c = \frac{2 \times 8}{12} (26)^3 + \frac{2}{12} (26) (8)^3 + 2 \times 8 (26) (13)^2$$

$$= 96000 \text{ in}^4$$

$$v_2 = \frac{105000}{832} - \frac{48000 \times 12 \times 13}{96000}$$

$$= 126 - 78 = 48 \text{ psi}$$

$$v_r = 126 + 78 = 204 \text{ psi} < 215 \text{ psi}$$

OK!

13.11 FLAT PLATE DEFLECTIONS.

FLAT PLATE FLOOR OF EXAMPLE 9.4.

$$l_a = l_b = 22 \text{ FT} = 264 \text{ IN.} \quad E_c = 3.6 \times 10^6 \text{ psi}$$

$$h = 8\frac{1}{2} \text{ IN.}$$

IMMEDIATE DEFLECTION DUE TO TOTAL DEAD LOAD

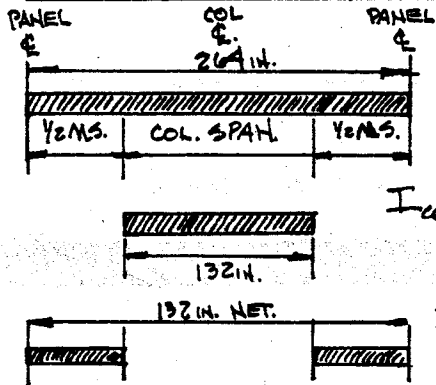

$$I_{\text{FRAME}} = \frac{1}{12}(264)(8.5)^3$$

$$= 13510 \text{ IN}^4$$

$$I_{\text{COL}} = \frac{1}{12}(132)(8.5)^3$$

$$= 6755 \text{ IN}^4$$

$$I_{\text{MID}} = \frac{1}{12}(66)(8.5)^3$$

$$= 6755 \text{ IN}^4$$

SAME IN BOTH DIRECTIONS.

REFERENCE DEFLECTION: (D.L. $\text{TOT} = 126.25 \text{ psf}$)

$$d_{f, \text{ref}} = \frac{126.25 \times 22 \times (22 \times 12)}{12 \times 384 \times 3.6 \times 10^6 \times 13510} = 0.0602 \text{ IN.}$$

AVERAGE OF THE LATERAL COEFFICIENTS FOR THE (+) AND (-) SECTIONS OF EACH STRIP.

$$\text{MIDDLE} \Rightarrow \frac{.25 + .40}{2} \approx 0.32 = \frac{M_{\text{MID}}}{M_{\text{FRAME}}}$$

$$\text{COLUMN} \Rightarrow \frac{.75 + .60}{2} \approx 0.68 = \frac{M_{\text{COL}}}{M_{\text{FRAME}}}$$

$$\text{THEN, } d_{f, \text{COL}} = 0.0602 \times 0.68 \times \frac{13510}{6755} = 0.0819 \text{ IN.}$$

$$d_{f, \text{MID}} = 0.0602 \times 0.32 \times 2.0 = 0.385 \text{ IN.}$$

THIS, THE DIFFERENCE IN MOMENTS TO THE LEFT AND RIGHT OF THE COLUMN IS:

$$(365 - 333) \times \frac{126.25}{346.75} = 11.65 \text{ FT KIPS.}$$

THIS WAS DETERMINED FROM THE CASE OF ALL SPANS FULLY LOADED WITH TOTAL FACTORED LOAD \uparrow THEN MULTIPLIED BY $\frac{DL}{FL_{\text{TOT}}}$.

$$\text{THIS, } \Theta = \frac{11650 \times 12}{157.3 \times 3.6 \times 10^6} = 0.000247.$$

$$\text{MIDSPAN } d_{e, \text{e}} = \frac{0.000247 \times 22 \times 12}{8} = 0.0082 \text{ IN. } \uparrow$$

$$\text{THIS, } d_{\text{COL}} = 0.0819 - 0.0082(z) = 0.0635 \text{ IN.}$$

$$d_{\text{MID}} = 0.385 - 0.0082(z) = 0.0221 \text{ IN.}$$

AND $d_{\text{MAX}} = 0.0876 \text{ IN.} \downarrow$ = IMMEDIATE DEFLECTION DUE TO TOTAL DEAD LOAD.

TOTAL LONG-TERM DEFLECTION DUE TO DEAD LOAD

$$\text{USING } \lambda = 3.0, \delta_{\text{LONG}} = 3.0(0.0876) = 0.2628$$

$$\text{SO TOTAL } d = 0.350 \text{ IN. } \downarrow$$

IMMEDIATE DEF. DUE TO $\frac{3}{4}$ FULL LL.

THE WORST CASE OF LINE LOAD (BOTH FOR MOMENTS \uparrow DEF.) WILL OCCUR WHEN ONLY PANEL C IS LOADED W/ $\frac{3}{4}$ LL. BECAUSE THIS SYSTEM IS IDEALIZED AS LINEAR ELASTIC,

SUPERPOSITION MAY BE USED. THIS;

$$d'_{f, \text{COL}} = 319 \times \left(\frac{126.25 + 75}{126.25} \right) = 0.1306 \text{ IN.}$$

$$d'_{f, \text{MID}} = 0.0385 \times 1.594 = 0.0614 \text{ IN.}$$

$$M_{\text{NET}} = 24.5 \times (126.25 + 75) / 346.75 = 14.22 \text{ FT KIP}$$

$$\text{THIS, } \Theta = \frac{14220 \times 12}{157.3 \times 3.6 \times 10^6} = 0.000301$$

$$d_{e, \text{r}} = \frac{1}{8}(0.000301) \times 22 \times 12 = 0.0099 \text{ IN. } \downarrow$$

THIS,

$$d_{\text{COL}} = 0.1306 + 2(0.0099) = 0.1504 \text{ IN.}$$

$$d_{\text{MID}} = 0.0614 + 2(0.0099) = 0.0812 \text{ IN.}$$

$$d_{\text{DL}} + d_{\frac{3}{4} \text{ LL}} = 0.1504 + 0.0812 = 0.2316 \text{ IN.}$$

$$d_{\frac{3}{4} \text{ LL}} = 0.1504 - 0.0812 = 0.144 \text{ IN.}$$

TOTAL IMMEDIATE DEF. DUE TO $\frac{3}{4}$ LL = 0.144 IN.

$$\text{TOTAL DEF.} \Rightarrow d_{\text{TOT}} = 0.35 + 0.144 = 0.494 \text{ IN. } \downarrow$$

14.1 WITH $\phi m_{nx} = \phi m_{ny} = 700 \text{ FT-LB/FT}$ IN EACH DIRECTION SLAB IS ISOTROPIC AND $\phi m_n = 7 \text{ FT-LB/FT}$ IN ANY DIRECTION.

FIRST MECHANISM:

BY VIRTUAL WORK, WITH SUCCESSIVE TRIALS FOR a EQUATE INTERNAL TO EXTERNAL WORK AND SELECT a TO GIVE MIN w :

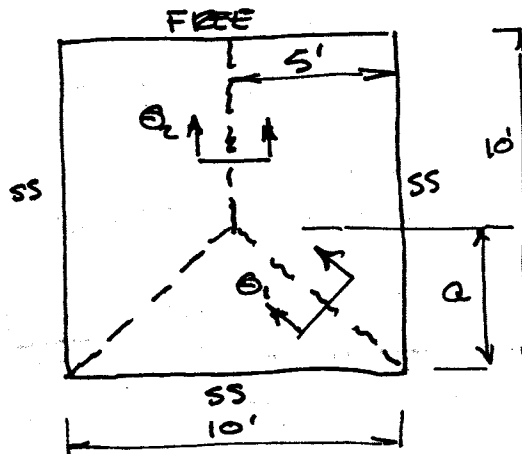

NEGLECT CORNER EFFECTS!

a	θ_1	θ_2	W_i	W_e	w
3'	.389	.40	7.33 m	6.14 w	6.14 w
4	.320	.40	6.50 m	6.67 w	6.67 w
5	.283	.40	6.00 m	6.94 w	6.94 w
6	.260	.40	5.67 m	7.05 w	7.05 w
7	.246	.40	5.43 m	7.06 w	7.06 w
8	.236	.40	5.25 m	6.98 w	6.98 w
6.5	.252	.40	5.54 m	7.07 w	7.07 w *

* GIVES LOWEST w .

SECOND MECHANISM:

AGAIN TAKE SUCCESSIVE a VALUES AND SELECT a TO GIVE MIN w :

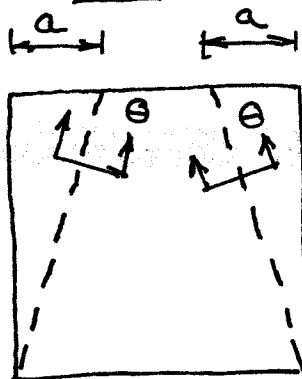

NEGLECT CORNER EFFECTS

14.1 (CON'T)

Q	W_i	W_e	m
1	20.2 m	46.7 w	2.31 w
2	10.4 m	43.3 w	4.17 w
3	7.27 m	40.0 w	5.50 w
4	5.80 m	36.7 w	6.32 w
5 (MAX POSSIBLE)	5.00 m	33.3 w	6.67 w *

* GIVES LOWEST w, BUT FIRST MECHANISM IS SEEN TO CONTROL, REQUIRING HIGHEST m FOR GIVEN w, HENCE LOWEST w FOR GIVEN m.

$$m = 7.07 w$$

$$7000 = 7.07 w$$

$$w = 990 \text{ PSF}$$

14.2 YIELD LINE ANALYSIS

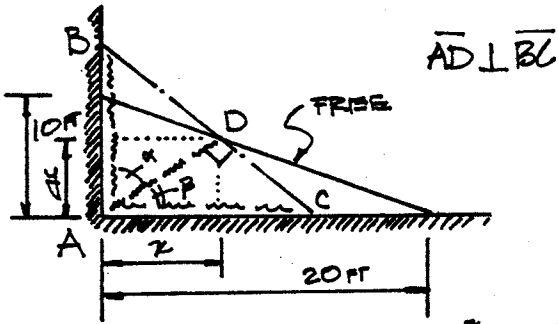

DUE TO GEOMETRY $\Rightarrow y = -\frac{z}{2} + 10$

VIRTUAL DISPLACEMENT FIELD
ROTATION FOR POSITIVE MOMENT.

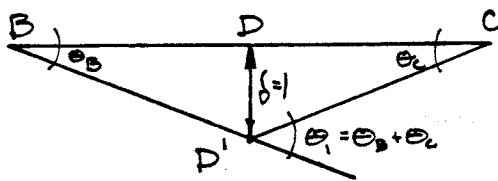

SMALL DISPLACEMENTS

$$\theta_2 \approx \tan \theta_2 = \frac{\delta}{BD} = \frac{\delta}{AD \tan \alpha} = \frac{\delta}{\sqrt{x^2 + y^2}}$$

$$\theta_3 \approx \tan \theta_3 = \frac{\delta}{DC} = \frac{\delta}{AD \tan \alpha} = \frac{\delta}{\sqrt{x^2 + y^2}}$$

$$\theta_1 = \theta_2 + \theta_3 = \left[\frac{\delta}{\sqrt{x^2 + y^2}} \right] \left(\frac{x}{x} + \frac{x}{y} \right)$$

ROTATION FOR NEGATIVE MOMENT.

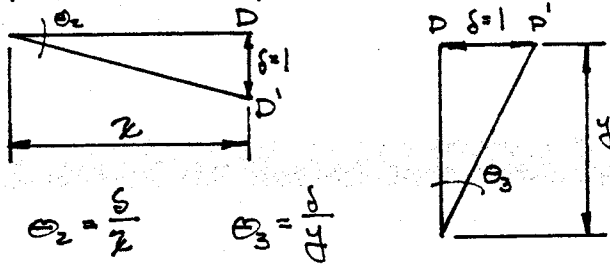

$$\theta_2 = \frac{\delta}{z} \quad \theta_3 = \frac{\delta}{y}$$

INTERNAL VIRTUAL WORK

$$W_i = [M^+ \cdot AD \cdot \theta_1] + [M^- \cdot 10 \cdot \theta_2] + [M^- \cdot 20 \cdot \theta_3]$$

$$W_i = \left[M^+ \sqrt{x^2 + y^2} \cdot \frac{\delta}{\sqrt{x^2 + y^2}} \left(\frac{x}{x} + \frac{x}{y} \right) \right] + M^- \left(10 \frac{\delta}{x} + 20 \frac{\delta}{y} \right)$$

AND

$$M^+ = \phi M_n = 2.67 \text{ KIP FT} \approx \frac{8}{3} \text{ KIP FT.}$$

$$M^- = \phi M_n = 40 \text{ KIP FT.}$$

So, $W_i = \frac{8}{3} \left(\frac{y}{x} + \frac{x}{y} \right) + \frac{40}{x} + \frac{80}{y}$
WHERE $y = (-x/2) + 10$.

EXTERNAL VIRTUAL WORK

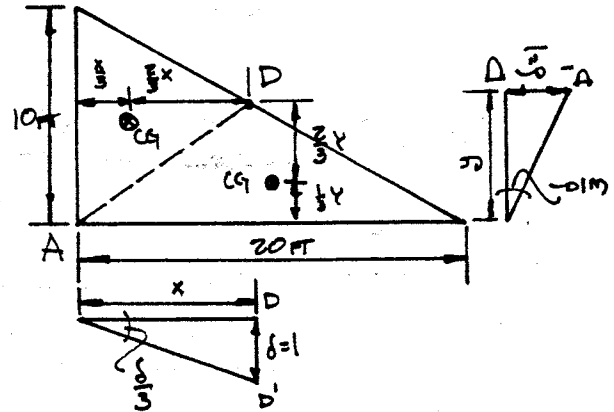

$$W_e = w_u \left[\frac{10 \times z}{2} \times \frac{\delta}{3} \right] + w_u \left[\frac{20 \times y}{2} \times \frac{\delta}{3} \right]$$

So, $W_e = w_u \left[\frac{5}{3} z + \frac{10}{3} y \right]$ WHERE $y = -\frac{x}{2} + 10$.

$$W_i = W_e$$

$$w_u = \left[\frac{8}{3} x \left(\frac{y}{x} + \frac{x}{y} \right) + \frac{40}{x} + \frac{80}{y} \right] / \left[\frac{5}{3} z + \frac{10}{3} y \right]$$

So,

X (FT)	Y (FT)	w_u (KIP/FT)
4.5	7.75	0.76
5.0	7.5	0.73
5.5	7.25	0.72
6.0	7.0	0.70
6.5	6.75	0.70
7.0	6.50	0.70
7.5	6.25	0.71
8.0	6.0	0.72
9.0	5.5	0.75

MINIMUM.

$$w_u = 0.70 \text{ KIPS/FT}^2$$

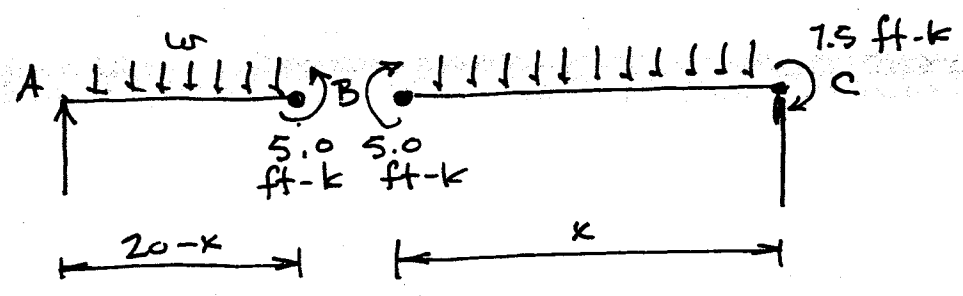
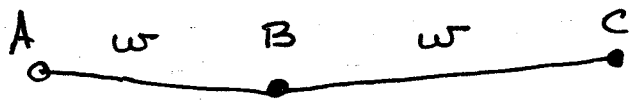
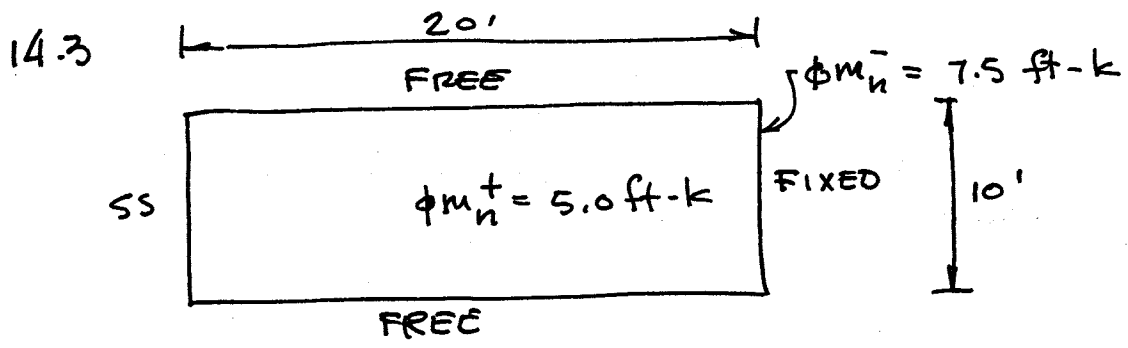

$$\sum M_B = 0 : w \left(\frac{20-x}{2} \right)^2 - 5.0 = 0$$

$$\sum M_C = 0 : \frac{wx^2}{2} - 5.0 - 7.5 = 0$$

SOLVE SIMULTANEOUSLY TO OBTAIN

$$x = 12.26'$$

$$w = .167 \text{ k/ft}$$

14.4

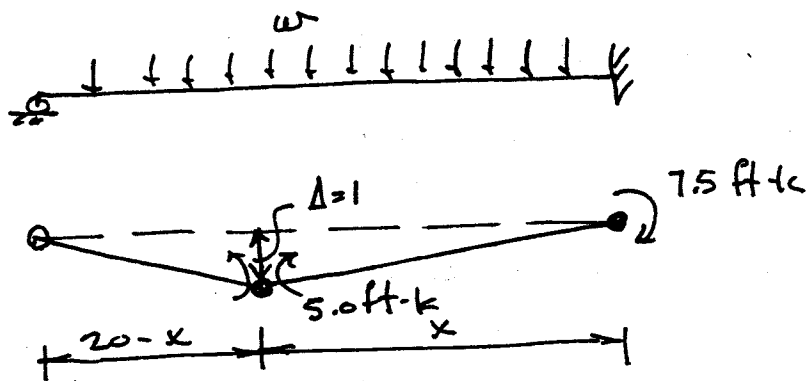

$$W_e = \frac{w \cdot k}{2} + \frac{w(20-x)}{2} = 10w$$

$$W_i = 75 \times \frac{1}{x} + 5 \left(\frac{1}{x} + \frac{1}{20-x} \right) = \frac{12.5}{x} + \frac{5}{20-x}$$

$$W_e = W_i \quad \therefore \quad 10w = \frac{12.5}{x} + \frac{5}{20-x}$$

SELECT SUCCESSIVE x :
TO OBTAIN MIN w

x	w
9	.184
10	.175
11	.169
12	.168
12.26	.167 *
13	.168
14	.173
15	.183

* LOWEST $w = .167 \text{ k/ft}$
CORRESPONDING TO $x = 12.26'$
NOTE: CORRECT VALUE FOR PRACTICAL PURPOSES
WOULD BE OBTAINED FOR $x = 12'$ OR $x = 13'$;
VALUE OF $x = 12.26'$ WAS OBTAINED FROM
RESULTS OF PROBLEM 12.3

14.5 YIELD LINE ANALYSIS AND SLAB DESIGN (VIRTUAL WORK)

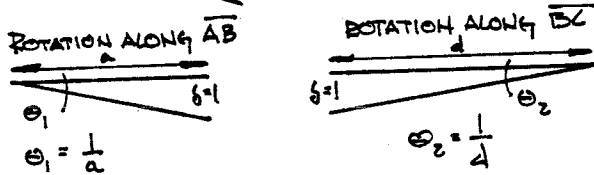
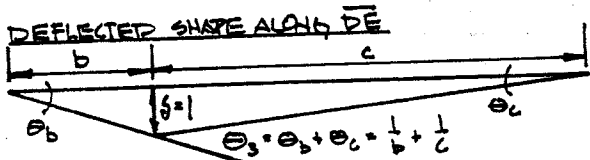
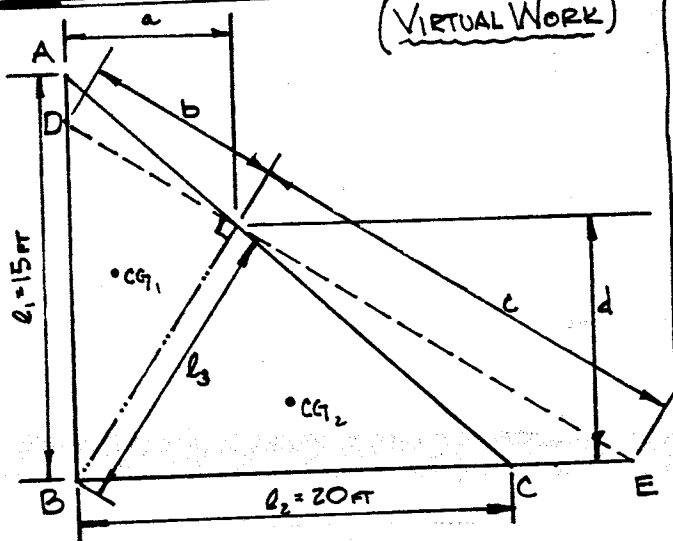

INTERNAL VIRTUAL WORK

$$W_i = M l_1 \theta_1 + M l_2 \theta_2 + M l_3 \theta_3$$

WHERE M IS THE LINEAR RESISTING MOMENT ALONG THE YIELD LINES.

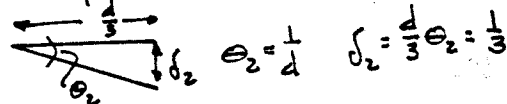
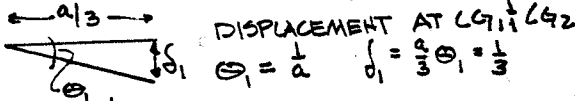

EXTERNAL VIRTUAL WORK

$$W_e = w A_1 \delta_1 + w A_2 \delta_2$$

$$= w \left(\frac{1}{2} l_1 a \right) \left(\frac{1}{3} \right) + w \left(\frac{1}{2} l_2 d \right) \left(\frac{1}{3} \right)$$

$$= \frac{1}{6} w (l_1 a + l_2 d)$$

$$W_i = W_e$$

$$M = \frac{\frac{1}{6} w (l_1 a + l_2 d)}{\frac{1}{6} (l_1/a + l_2/d + l_3/b + l_3/c)}$$

AND $l_1 = 15$ FT, $l_2 = 20$ FT. BY VARYING THE VALUES OF a, b, c, d, l_3 . THE MAXIMUM VALUE OF M IS FOUND. THE RESPECTIVE NO'S: I.E. 5', 5.5', 27.35', 11.25', 12.2', $m = 6.72w$.
max: 8.5', 12.1', 12.4', 8.7', 12.1', $M = 8.32w$.

A GOOD EST FOR DEPTH IS $h = \frac{\text{PERIMETER}}{130} = 4''$, BUT THIS WOULD NOT BE DEEP ENOUGH FOR TWO LAYERS OF STEEL + COVER SO USE 6''.

LOADS - DL = 75 + 15 = 90 psf, LL = 40 psf.
 $w = 1.4(90) + 1.7(40) = 194$ psf.
 $M = 8.32(194) = 1.61$ KIP FT / FT.

REQUIRED REINFORCEMENT $d_{avg} = 4''$

$$A_{s, MIN} = 0.0018 \times 12 \times 6 = 0.130 \text{ IN}^2$$

$$p_{min} = 0.130 / 4 \times 12 = 0.0027.$$

TRY $a = 0.29$.

$$A_s = 1.61 \times 12 / 0.9 \times 60 \times (4 - 0.29) = 0.093 \text{ IN}^2$$

$$a = 0.093 \times 60 / 0.85 \times 4 \times 12 = 0.14 \text{ IN}.$$

FOR $a = 0.14 \rightarrow A_s = 0.091 \text{ IN}^2$ $a = 0.13 \text{ IN}.$

BUT $A_{s, MIN}$ APPLIES, SO; FOR M-REGIONS, PLACE STEEL \perp TO EDGE. USE 1-#3 PER FOOT OF SLAB ($A_s = 0.11 \text{ IN}^2$) (CLOSE ENOUGH)

$a = 0.14 \text{ IN}.$ $M_f = 1.94$ KIP FT / FT.

PLACE #3 BARS @ 12''.

$l_d = 13$ INCHES. AND ESTIMATED INFLECTION POINT AT $\frac{\text{SPAN}}{6} \Rightarrow$ ALONG AB = $l_d = 55''$

ALONG BC = $l_d = 42''$

FOR POSITIVE SECTIONS, PLACE AN ORTHOGONAL GRID AT BOTTOM OF SLAB \parallel \perp TO FREE EDGE.

USE #3 @ 12''.

$$\text{SHEAR } V_c = 2 \times \sqrt{4000} \times (15 + 20) \times (12) \times 4 + 1000$$

$$= 180.6 \text{ KIPS}.$$

$$V_u = w A = 0.194 \times 150 = 29.1 \text{ KIPS}$$

$$F.S = 180.6 / 29.1 = 6.2 \text{ OK}.$$

14.5 (CONT)

DEFLECTION

FOR AN UPPER BOUND, CONSIDER A ONE FOOT STRIP ALONG FREE EDGE.

$$w = 90 \text{ psf} + 40 \text{ psf} = 130 \text{ psf.}$$

max δ .

$$\delta = w l^4 / 384 EI ;$$

$$E = 57 \sqrt{f'_c} = 3600 \text{ ksi}$$

$$I = I_g = \frac{1}{12} (12)(6)^3 = 216 \text{ in}^4$$

$$M_{cr} = (7.5)(4000)(216)/3 = 2.846 \text{ K-FT}$$

$$M_a^+ = 0.130 (25)^3 / 24 = 3.285 \text{ K-FT.}$$

$$I_{cr} = 13.2 \text{ in}^4$$

$$I_{e_t} = 133.7 \text{ in}^4$$

$$M_a^- = 6.77 \text{ K-FT}$$

$$I_{e_t} @ A: I_{cr} = 7.40 \text{ in}^4$$

$$I_{e_A} = 22.9 \text{ in}^4$$

$$e_C: I_{cr} = 4.38 \text{ in}^4$$

$$I_{e_C} = 20.1 \text{ in}^4$$

$$I_e = \frac{1}{2} [(22.9 + 20.1)/2 + 133.7] = 77.6 \text{ in}^4$$

$$\delta = \frac{0.130 \times 25^4 \times 12^3}{384 \times 3600 \times 77.6} = 0.817 \text{ in. OK.}$$

THIS IS A HIGH UPPER BOUND $\frac{1}{2}L$ IT DOES NOT TAKE INTO ACCOUNT THE CONTINUITY OF THE SLAB ALONG THE INSIDE EDGE OF THE STRIP CONSIDERED. CONTINUITY WILL BOTH RESTRAIN THE DEFLECTION AND INCREASE THE STIFFNESS.

14.6 YIELD LINE SLAB ANALYSIS.

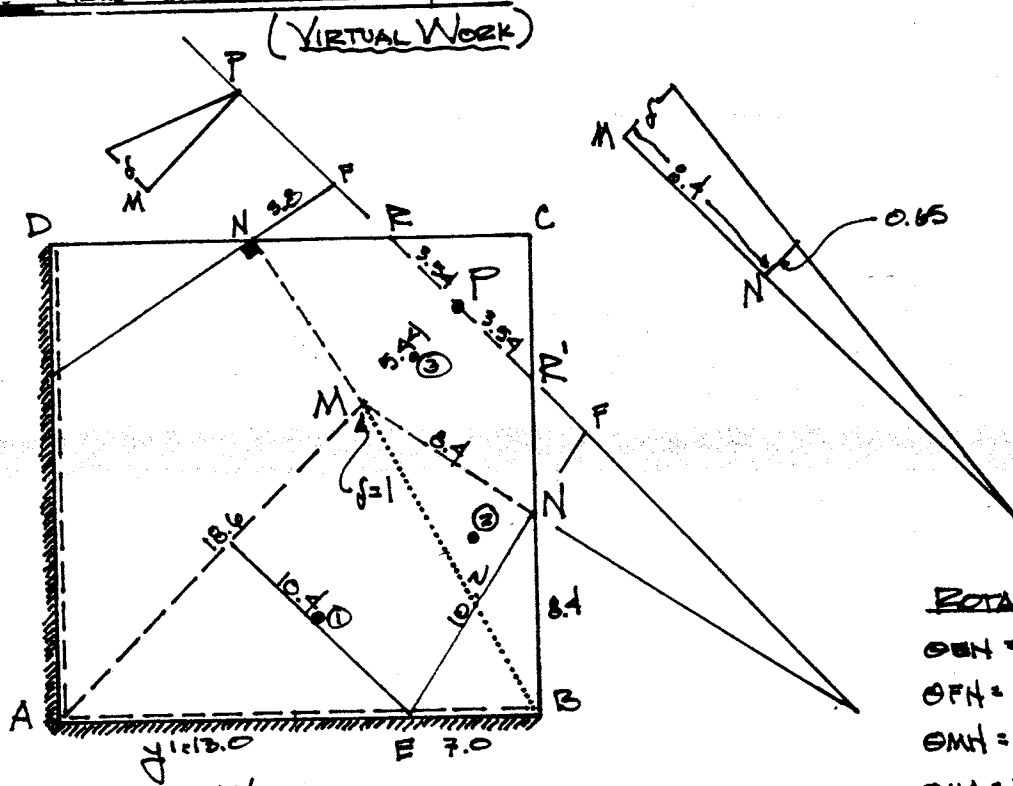

INTERNAL WORK.

$$M_+ (\overline{AM} \theta_{AM} + 2 \overline{MN} \theta_{MN}) + M_- (\overline{RB} \theta_{RB} + 2 \overline{NR} \theta_{NR}^*)$$

$$6.5 (18.6 \times 0.115 + 2 \times 8.4 \times 0.235) + 8.9 (20 \times 0.077 \times 2 + 2 \times 3.54 \times 0.061)$$

$$= 70.80$$

EXTERNAL WORK.

$$2w \left[\left(\frac{1}{2} \times 13 \times 20 \times 0.33 \right) + \left(\frac{1}{2} \times 8.4 \times 7.0 \times 0.41 \right) \right] + 2 \times 0.33 \times w \times$$

$$\left(\frac{1}{2} \times 3.54 \times 5.41 + \frac{1}{2} \times 6.49 \times 5.33 \right)$$

$$= 129.44 w.$$

AND EQUATING THE TWO $70.80 = 129.44 w$, $w = 0.547 \text{ pf.}$

THIS PROCEDURE IS REPEATED A NUMBER OF TIMES, USUALLY AT LEAST THREE, UNTILL THE MIN. w IS FOUND. EACH TIME, THE GEOMETRY IS CHANGED A SMALL AMOUNT, i.e. $y' = 13.5'$ INSTEAD OF $13.0'$.

* CALCULATION IMPLIES A NEG. Y.L. ALONG RR' , THIS IS UNLIKELY! ROTATION ABOUT RR' WOULD LIKELY OCCUR, AS PIPE COLUMN PROVIDES LITTLE ROTATIONAL RESTRAINT AT JOINT. BOTH INTERNAL AND EXTERNAL WORK EXPRESSIONS WOULD CHANGE. THE POSSIBILITY OF A HINGE ALONG RR' SHOULD BE INVESTIGATED - THIS CASE STATICALLY DETERMINATE!

ROTATIONS

$$\theta_{MN} = \frac{0.65}{10.2} = 0.064$$

$$\theta_{NR} = \frac{0.65}{3.8} = 0.171$$

$$\theta_{MN} = 0.064 + 0.171 = 0.235$$

$$\theta_{MA} = 2 \left(\frac{0.6}{18.6} \right) = 0.115$$

$$\theta_{RB} = \frac{1}{13} = 0.077$$

$$\theta_{NR} = \left(\frac{0.33}{5.41} \right) = 0.061$$

$$\Delta_1 = \frac{1}{3} \times 1 = 0.333$$

$$\Delta_2 = \frac{1 + 0.65/2}{3} = 0.41$$

$$\Delta_3 = \frac{1}{3} \times 1 = 0.33$$

14.8 $h = 7''$ LONG DIR $d = 6''$
 SHORT DIR $d = 5.5''$

FIRST MECHANISM:

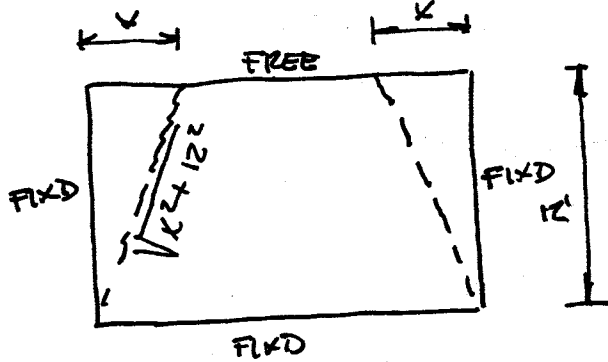

MOMENT RESISTANCE:

LONG DIR:

	d	A_s/ft	ρ	m
POS	6"	.17	.00238	4.53 k
NEG	6"	.20	.00218	5.27
BAND	6"	.61	.00847	15.20

SHORT DIR:

POS	5.5	.17	.00258	4.11
NEG	5.5	.20	.00303	4.82

TAKE SUCCESSIVE x VALUES TO OBTAIN LOWEST
 $w_u = .619 \text{ k/ft}^2$ AT $x = 8.9'$

SECOND MECHANISM:

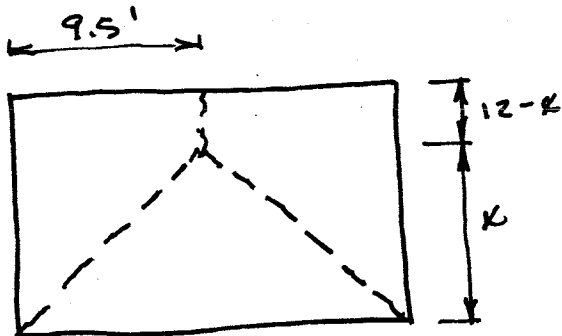

TAKE SUCCESSIVE TRIALS OF x TO OBTAIN LOWEST
 $w_u = .557$ AT $x = 9.8'$

THUS DESIGN STRENGTH OF SLAB = $\phi w_u = .9 \times .557$
 $= .501 \text{ k/ft}^2$

14.10 FIRST MECHANISM:

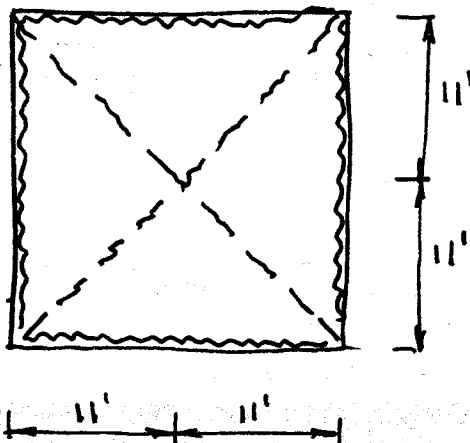

EXTERNAL WORK

$$W_e = 4 \left(\frac{1}{2} \times 22 \times 11 \times \frac{1}{3} \right) w$$

$$= 161.33 w$$

INTERNAL WORK (CONSIDER BANDED REBAR PATTERN):

NEG YL'S $W_i = 107.48 \text{ k}$

POS YL'S $W_i = 62.80$

TOTAL $W_i = 170.28$

THEN $161.33 w = 170.28$

$w = 1.055 \text{ k/ft}^2$

SECOND MECHANISM:

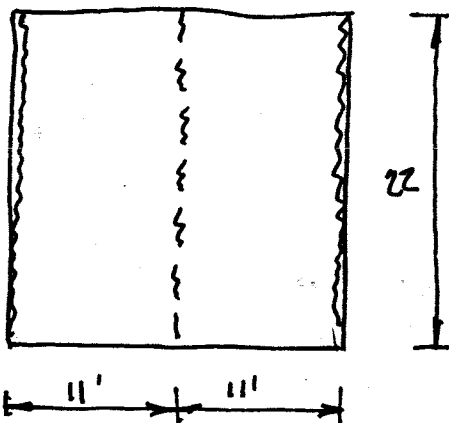

$W_e = 242 w$

$W_i = 53.74 + 31.40 = 85.14 \text{ k}$

$w = 85.14 / 242 = .352 \text{ k/ft}^2$

THIRD MECHANISM:

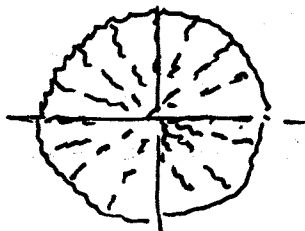

$P = 2\pi (m + m')$

$m = 8.726 \text{ k/ft}$ Bot

$m' = 19.896 \text{ k/ft}$ Top

$P = 2\pi (8.726 + 19.896) = 179.8 \text{ k}$

CORRESPONDING TO:

$w = \frac{179.8}{22 \times 22} = .372 \text{ k/ft}^2$

SO COLLAPSE LOAD = 352 psf

VERY CLOSE TO DESIGN FACTORED LOAD = 346 psf

15.1 $f'_c = 4000 \text{ psi}$ $f_y = 60,000 \text{ psi}$

TRY $h = \frac{24 \times 4 \times 12}{180} = 6.4 \text{ in}$

SAY $h = 6.5 \text{ in}$ $d_{AV} = 6.5 - 1.25 = 5.25 \text{ in}$

$w_o = \frac{6.5}{12} (150) = 81 \text{ psf}$

$w_L = 100 \text{ psf}$

$w_u = 1.2w_o + 1.6w_L = 1.2(81) + 1.6(100) = 257 \text{ psf}$

TYPICAL MIDDLE STRIP

$$M_{\text{ft}} = R L_{\frac{1}{2}} - \frac{w L^2}{2} = 2316(12) - 257 \times 6 \times 9 - 129 \times 6 \times 3 = 11,600 \text{ ft-lb}$$

$$R = \frac{M_u}{\phi b d^2} = \frac{11,600(12)}{0.9(12) 5.25^2} = 468$$

$\rho = 0.0084$ TABLE A.5

$A_s = 0.0084(12) 5.25 = 0.53 \text{ in}^2/\text{ft}$
USE #5(16) AT 7 in. = $0.53 \text{ in}^2/\text{ft}$

TYPICAL EDGE STRIP

$M_{\text{ft}} = 774(3) = 2322 \text{ in}^2$

$$R = \frac{2322(12)}{12(0.9) 5.25^2} = 94$$

$\rho = 0.0016$

$\rho_{\text{min}} = 0.0018 \frac{6.5}{5.25} = 0.0022$ Controls

$A_s = 0.0022(12) 5.25 = 0.14 \text{ in}^2/\text{ft}$
USE No. 4(13) at 17 in $< 18''$ & $< 3h = 19.5''$ ok.

CHECK CUT OFF FOR 1/2 BARS IN MIDDLE STRIP

No. 5(16) AT 14 in. = $0.27 \text{ in}^2/\text{ft}$

$\rho = 0.0042$ $R = 243$

$$\phi M_n = 0.9(243) 12 (5.25)^2 \frac{1}{12} = 6027 \text{ Ft-lb}$$

$$2316x - 243x^2 = 6027$$

$x = 2.31 \text{ ft}'$

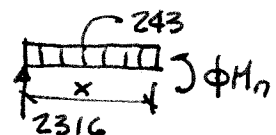
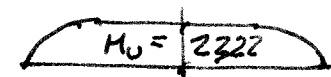
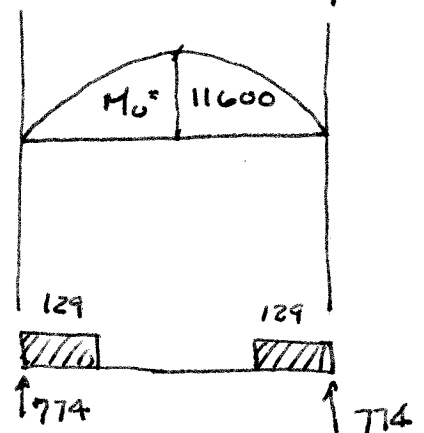
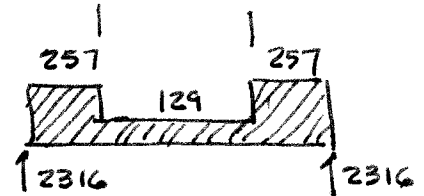
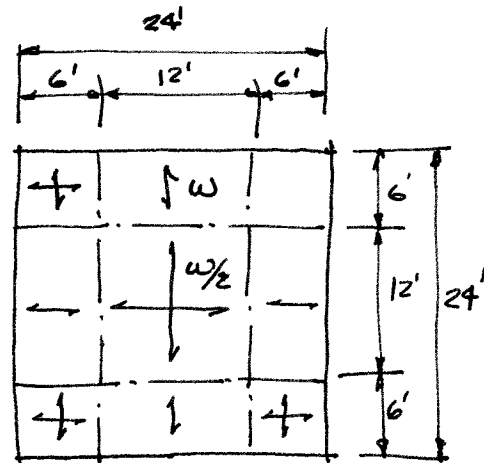

(Con't.)

15.1 (CONT.)

CARRY BARS $\left\{ \begin{array}{l} d = 5.25 \text{ in} \\ 12d_b = 7.5 \text{ in} \end{array} \right\}$ PAST, SO CUT $\frac{1}{2}$ BARS IN MIDDLE

STRIP AT $2.31 - 7.5/12 = 1.68'$ SAY 1'-10" FROM SUPPORT ϕ

DO NOT CUT BARS IN EDGE STRIP SINCE THEY ARE NEEDED FOR ρ_{min}

CHECK SHEAR AT d FROM SUPPORT ϕ

$$V_u = 2316 - 257\left(\frac{5.25}{12}\right) = 2200 \text{ lb}$$

$$\phi V_c = \phi 2\sqrt{f_c'} b d = 0.75(2)\sqrt{4000} 12(5.25) = 5980 \text{ lb} > V_u \text{ OK}$$

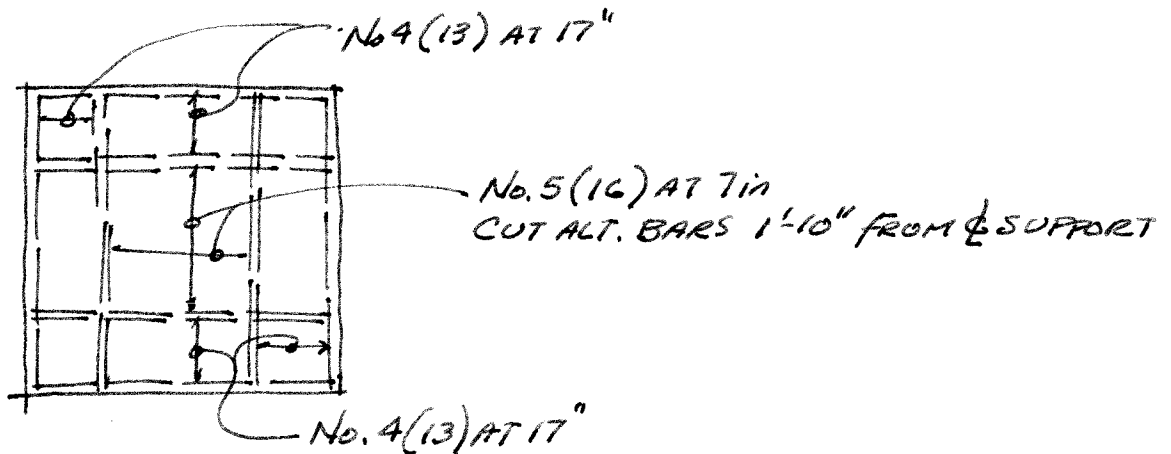

15.2 $f_c' = 4000 \text{ psi}$ $f_y = 60,000 \text{ psi}$
 $w_d = 30 \text{ psf}$ $w_l = 100 \text{ psf}$

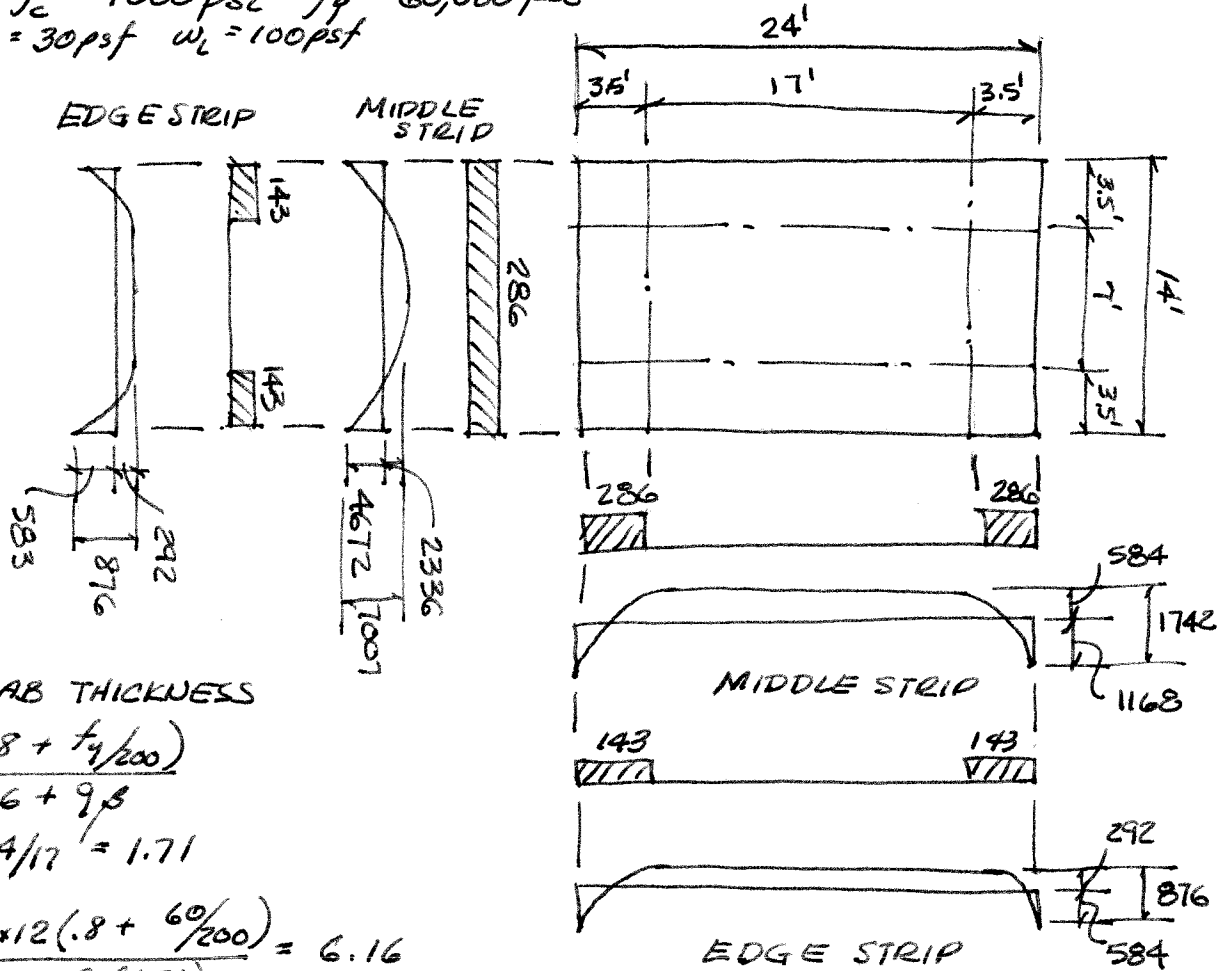

TRIAL SLAB THICKNESS

$$h = \frac{l_n (.8 + f_y/200)}{36 + 9\rho}$$

$$\rho = 24/17 = 1.71$$

$$h = \frac{24 \times 12 (.8 + 60/200)}{36 + 9(1.71)} = 6.16$$

TRY $h = 6''$

$$d_{\text{short}} = 6 - 1 = 5 \text{ in}$$

$$d_{\text{long}} = 6 - 1.5 = 4.5 \text{ in}$$

$$w_o = \frac{6}{12} (150) = 75 \text{ psf}$$

$$w_u = 1.2(75 + 30) + 1.6(100) = 286 \text{ psf. } \rightarrow \text{MOMENTS SHOWN ABOVE.}$$

$$\text{CAPACITY OF } \rho_{\text{min}} = 0.0018 \left(\frac{6}{4.5} \right) = 0.0024$$

↑ TEMP & SHRINK ON GROSS SECTION

$$R = 141 \quad \phi M_N = 0.9(141)12(4.5)^2 = 2570 \text{ FT-LB}$$

THIS COVERS ALL BUT SHORT DIRECTION MIDDLE STRIP

$$\text{NEG. MOMENT} \quad R = \frac{4672(12)}{0.9(12)5^2} = 208 \quad \rho = 0.0036$$

$$A_s = 0.0036(12 \times 5) = 0.22 \text{ in}^2/\text{ft} \quad \text{No. 4 (13) AT 11" = } 0.22 \text{ in}^2/\text{ft}$$

ELSEWHERE

$$A_s = 0.0018(12 \times 6) = 0.13 \quad A_s = \text{No. 4 AT 18 in} \begin{cases} 3h = 18 \\ \text{CODE LIMIT} = 18 \end{cases}$$

(CONT.)

15.2 (CONT)

BAR CUTOFF - NOT REQ'D AS THE RESULTING $A_s < A_{s \min}$

CHECK SHEAR - SHORT DIRECTION - MIDDLE STRIP

$$V_u = \frac{286(14)}{2} = 2002 \text{ lb} \quad (\text{CAN CORRECT FOR } d, \text{ BUT NOT CRITICAL IN THIS CASE})$$

$$\phi V_c = \phi 2\sqrt{f'_c} b d = 0.75(2)\sqrt{4000}(12)(4.5) = 5122 > V_u \quad \text{OK}$$

15.3 $f_c' = 4000 \text{ psi}$, $f_y = 60,000 \text{ psi}$

$w_d = 30 \text{ psf}$
 $w_L = 100 \text{ psf}$

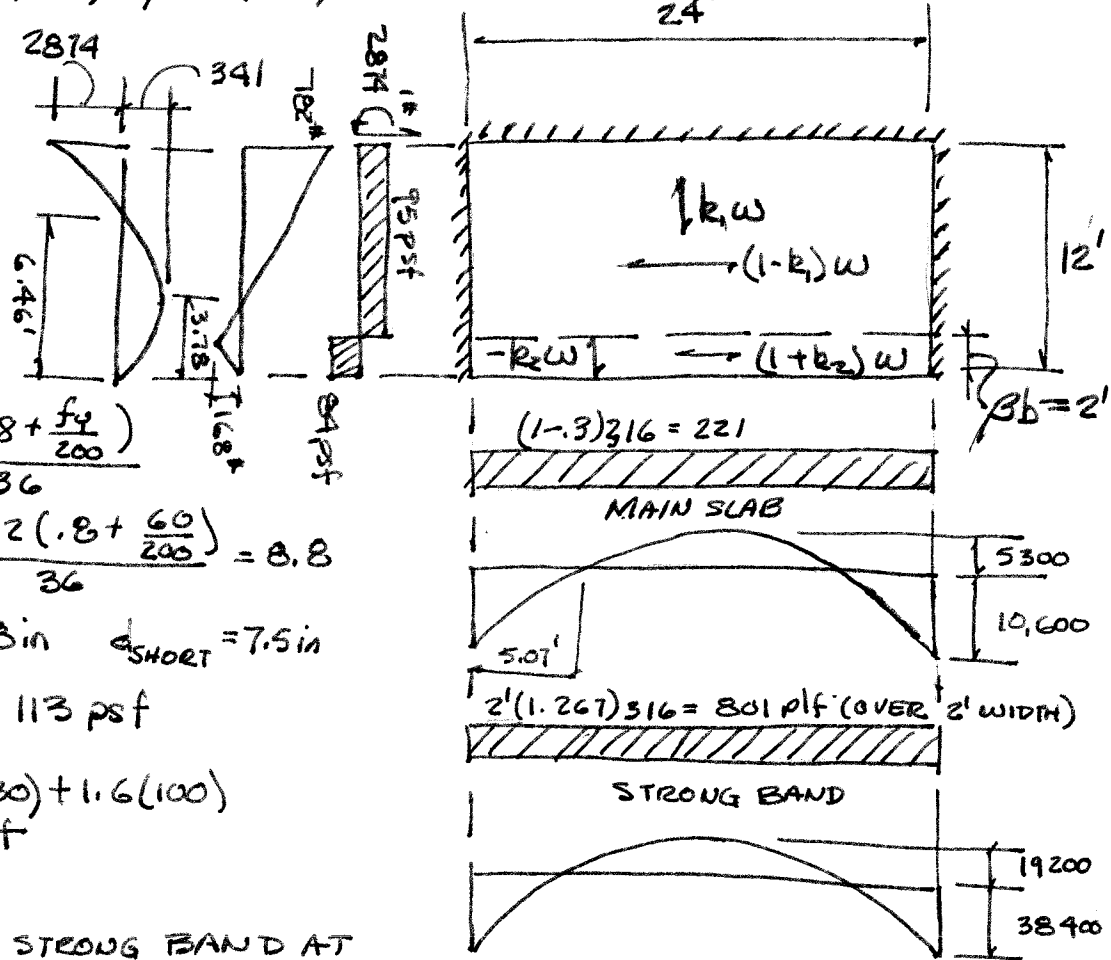

TRY $h = \frac{w (.8 + \frac{f_y}{200})}{36}$
 $= \frac{24 \cdot 12 (.8 + \frac{60}{200})}{36} = 8.8$

$h = 9 \text{ in}$ $d = 8 \text{ in}$ $d_{\text{SHORT}} = 7.5 \text{ in}$

$w_o = \frac{9}{12} (150) = 113 \text{ psf}$

$w_u = 1.2 (113 + 30) + 1.6 (100)$
 $= 316 \text{ psf}$

USE 2' WIDE STRONG BAND AT FREE EDGE $\beta = \frac{2}{12} = \frac{1}{6}$

TRY k_1 SO ρ_{MIN} CONTROLS IN X-DIRECTION

$\rho_{\text{MIN}} = 0.0018 \frac{9}{8} = 0.0020$ $R = 118$ $\phi M_x = 6000 \text{ ft-lb/ft}$

$M_{xf} = (1 - k_1) \frac{w l^2}{8} \frac{1}{3} = (1 - k_1) \frac{316 (24)^2}{8} \frac{1}{3} = 6800$ $k_1 = 0.10$

USE $k_1 = 0.30$ RATHER THAN HAVE 90% OF THE LOAD RUN IN THE LONG DIRECTION.

$w_y = k_1 w = 0.30 (316) = 95 \text{ psf}$

$w_x = (1 - k_1) w = (1 - 0.3) 316 = 221 \text{ psf}$

SELECT k_2 SO THAT $M_{ys} = \frac{1}{2}$ CANTILEVER MOMENT

$M_{ys} = \frac{1}{2} \frac{w_y l^2}{2} = \frac{1}{2} \frac{95 (11)^2}{2} = 2874 \text{ ft-lb}$

FROM EQ. (15.18) $k_2 = \frac{0.30 (1 - \frac{1}{6})^2 + 2 (2874) / (316 \times 144)}{\frac{1}{6} (2 - \frac{1}{6})} = 0.267$

SO UPLIFT OF $0.267 (316) = 84 \text{ psf}$ IS PROVIDED BY STRONG BAND

(CON'T.)

15.3 (CONT.)

MIN. REINFORCEMENT CAPACITY

$$\rho_{min} = 0.0018 \frac{9}{8} = 0.00203 \quad R = 123 \quad M_u = \phi M_n = 7130 \text{ Ft-lb/ft}$$

THIS COVERS THE PROPER CANTILEVER (SHORT) DIRECTION AND M_x Y DIRECTION. $A_s = 0.0018(12)9 = 0.19$ No. 4(13) AT 12" IN

DESIGN X-DIR. SLAB

NEG MOMENT $R = \frac{15900(12)}{0.9(12)8^2} = 276 \quad \rho = 0.0048$

$$A_s = 0.0048(12)8 = 0.46 \text{ in}^2/\text{ft} \text{ No. 4(13) AT 5 in} = 0.48 \text{ in}^2/\text{ft} \text{ (OR No. 5(16) AT 8 in)}$$

STRONG BAND

POS $M_{xf} = 19200 \quad R = \frac{19200(12)}{.9(24)8^2} = 167 \quad \rho = 0.003$

$$A_s = 0.003(24)8 = 0.58 \text{ USE 3 No. 4(13)}$$

NEG $M_{xs} = 38,400 \quad R = \frac{38400(12)}{0.9(24)8^2} = 333 \quad \rho = 0.0058$

$$A_s = 0.0058(24)8 = 1.11 \text{ in}^2 \text{ USE 4 No. 5(16)}$$

CUTOFFS —

RUN POSITIVE MOMENT CONTINUOUS OTHERWISE $\rho < \rho_{min}$
 NEGATIVE MOMENTS $d = 8"$
 $12d_b = 12(\frac{5}{8}) = 7.5 \text{ in} \quad \{ d \text{ controls}$
 SHORT DIRECTION = $12' - 6.46 + \frac{8}{12} = 6.2' - \text{SAY } 6'-3"$
 Y DIRECTION = $5.07' + \frac{8}{12} = 5.73' \text{ SAY } 5'-9"$

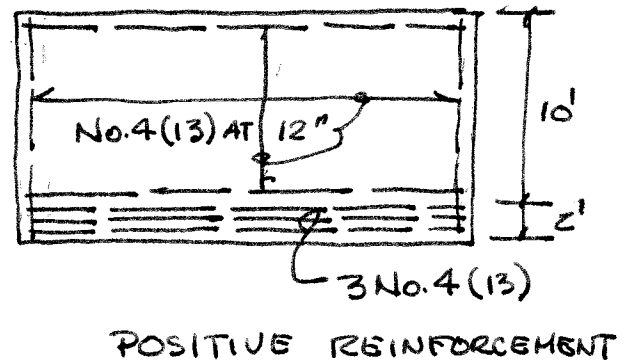
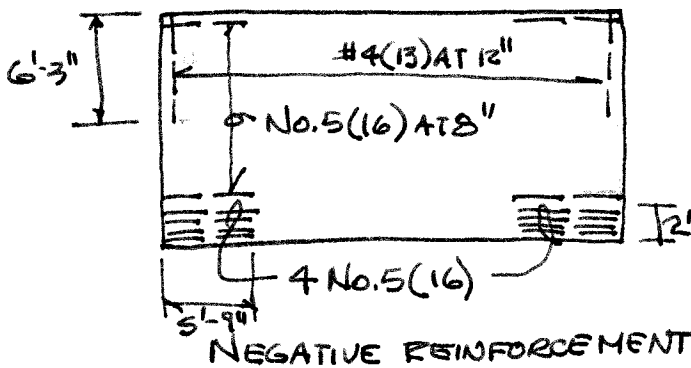

NOTE ALL BARS REQUIRE
 HOOKS OR FULL ANCHORAGE
 AT SLAB EDGE

15.4 - COUNTERFORT RETAINING WALL.
SEE SOLN. FOR 15.3 OR 17.2 FOR AN ALTERNATIVE
REINFORCEMENT LAYOUT.

15.5

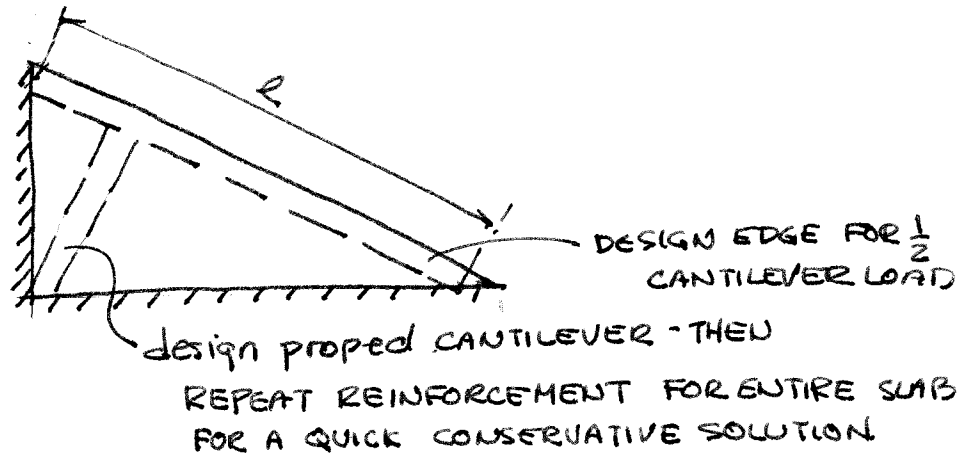

15.6

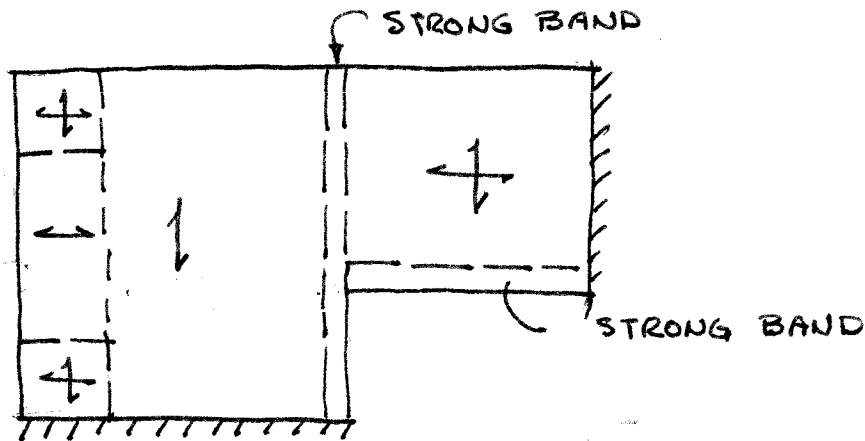

Instructor's Solutions Manual

to accompany

Design of Concrete Structures, 14e
Nilson/Darwin/Dolan

Chapters 16-20

The authors welcome feedback on the problem solutions and on the text in general. Please e-mail any comments to David Darwin at: daved@ku.edu

PROPRIETARY AND CONFIDENTIAL

This Manual is the proprietary property of The McGraw-Hill Companies, Inc. ("McGraw-Hill") and protected by copyright and other state and federal laws. By opening and using this Manual the user agrees to the following restrictions, and if the recipient does not agree to these restrictions, the Manual should be promptly returned unopened to McGraw-Hill: This Manual is being provided only to authorized professors and instructors for use in preparing for the classes using the affiliated textbook. No other use or distribution of this Manual is permitted. This Manual may not be sold and may not be distributed to or used by any student or other third party. No part of this Manual may be reproduced, displayed or distributed in any form or by any means, electronic or otherwise, without the prior written permission of the McGraw-Hill.

16-1 CONTINUOUS STRIP FOOTING

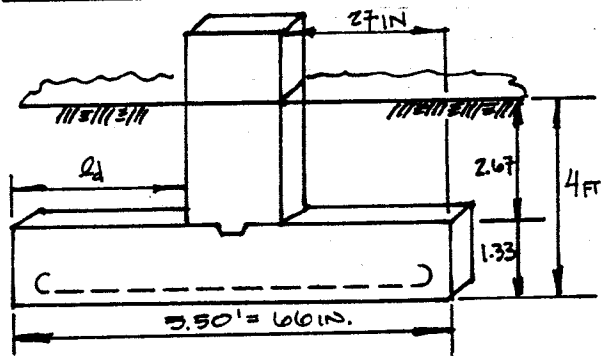

$$D = 25000 \text{ lb/ft}$$

$$L = 15000 \text{ lb/ft}$$

$$D+L = 40000 \text{ lb/ft}$$

ASSUME DEPTH OF FOOTING = 16 IN.

$$1.33 \times 150 = 200 \text{ lb/ft}^2$$

$$\text{FILL} \Rightarrow 2.67 \times 120 = 320 \text{ lb/ft}^2$$

a) NET BEARING CAPACITY, q_a

$$q_a = 8000 - 200 - 320 = 7480 \text{ lb/ft}^2$$

$$b = \frac{40000}{7480} = 5.35 \text{ FT}; \text{ say } 5.5 \text{ FT.}$$

b) AT FACE OF LOAD, REACTION CAUSING

$$V_u \uparrow M_u ;$$

$$q_u = \frac{1}{b}(w) = \frac{1.2 \times 25 + 1.6 \times 15}{5.50} \times 1000$$

$$= 9820 \text{ lb/ft}^2$$

$$\text{ASSUMING } h = 16 \text{ IN.}, d = 16 - 3.5 = 12.5 \text{ IN.}$$

CRITICAL SECTION FOR SHEAR AT

$$27 - 12.5 = 14.5 \text{ IN. FROM FACE.}$$

$$V_u = 9820 \frac{14.5}{12} = 11,870 \text{ lb}$$

$$\phi V_c = .75 \times 2\sqrt{3000} \times 12d = 986d$$

$$d = 11870 / 986 = 12.0 \text{ IN.}, \text{ WHICH WAS ASSUMED}$$

c) CRITICAL SECTION FOR MOMENT

AT WALL FACE ;

$$M_u = 9820 \frac{2.25^2}{2} = 24,900 \text{ FT-LB}$$

ASSUMING AN 'a' OF 2 IN,

$$d - \frac{a}{2} = 12 - 1 = 11 \text{ IN.}$$

$$A_s = \frac{M_u}{\phi S_y (d - \frac{a}{2})}$$

$$= \frac{24,900 \times 12}{.85 \times 60000 \times 11} = 0.50 \text{ IN}^2/\text{FT.}$$

CHECK 'a'

$$a = \frac{A_s f_y}{.85 f_c' b}$$

$$= \frac{.50 \times 60}{.85 \times 3 \times 12} = 1.10$$

$$d - \frac{a}{2} \approx 11.5 \text{ IN. OK!}$$

$$A_s = \#6(\#9) @ 10 \text{ IN.} = 0.53 \text{ IN}^2/\text{FT}$$

$$\frac{L_d}{d_b} = \frac{f_y \alpha \beta \lambda}{20 \sqrt{f_c'}} = \frac{60000(1)(1)(1)}{20 \sqrt{3000}} = 55$$

$$L_d = 55(.75) = 41 \text{ IN.}$$

$$\text{DST. AVAIL} = 27 \text{ IN.}$$

USE STANDARD HOOK

16.2 FOOTING DESIGN.

$$P = D + L = 500 + 514 = 1014 \text{ KIPS}$$

ASSUME AVG. WT. OF FILL AND CONCRETE TO BE 125 PCF.

$$\text{AT } 60 \text{ FT, PRESSURE} = 6 \times 125 = 750 \text{ PSF}$$

$$\text{NET BEARING CAPACITY} = 8000 - 750 = 7250 \text{ PSF}$$

$$q_e = 7,250 \text{ PSF}$$

$$A_f = 1014 / 7.25 = 139.86 \text{ SQ FT.}$$

USE \star 12 FT \times 12 FT SQUARE. $A_f = 144$

$$q_u = \frac{1.2 \times 500 + 1.6 \times 514}{144} = 9.88 \text{ KEF}$$

$$V_u = 1420 \text{ KIPS (CONSERVATIVE, DID NOT SUBTRACT } b(q_u))$$

$$V_c = 4\sqrt{3000} d (4 \times 22 + d) = 16\sqrt{3000} (22d + d)$$

$$V_u = \phi V_c; 1420 = .75 \times .876 \times (22d + d) \\ d = 35.5 \text{ IN.}$$

ASSUME $d = 36 \text{ IN.}$

$$V_u = 9.88 \times [144 - (\frac{22+36}{12})^2] = 1192 \text{ KIPS}$$

$$\phi V_c = .85 \times 4 \times \sqrt{3000} \times 4 \times (22 + 36) \times 36 = 1372 \text{ KIPS, SO OK FOR PUNCHING.}$$

CHECK BEAM SHEAR AT d' FROM FACE;

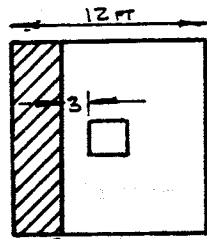

$$\text{AREA} = 12 \times (6 - \frac{11}{12} - 3) = 250 \text{ FT}^2$$

$$V_{u2} = 9.88 \times 25 = 247 \text{ KIPS}$$

$$V_c = 2\sqrt{3000} \times 12 \times 12 \times 0.036 = 568 \text{ KIPS.}$$

$$\phi V_c = 426 > 247 \text{ kip so,}$$

OK FOR 1-WAY SHEAR.

COMPUTE BENDING MOMENT AT FACE OF COL.

$$M_u = 9.88 \times 12 \times \frac{1}{2} \times 5.083^2 \times 12 = 18,400 \text{ KIP-IN.}$$

$$A_s = \frac{18,400}{.9 \times 60 \times (36 - 2)} = 10.0 \text{ FOR } a = 4"$$

CHECK

$$a = \frac{10.0 \times 60}{.85 \times 3 \times 144} = 1.63 \text{ IN.}$$

$$A_s = 18,400 / 54 \times (36 - 0.81) = 9.68$$

$$a = \frac{9.68 \times 60}{.85 \times 3 \times 144} = 1.58 \text{ IN. OK.}$$

$$A_{\text{MIN}} = 0.0018 \times 39 \times 144 = 10.12 \text{ IN}^2$$

$$f_{\text{MIN}} = 200 / 60000 = 0.0033.$$

$$A_s = 0.0033 \times 39 \times 144 = 18.72 \text{ IN}^2. \leftarrow \text{USE } 18.72 / 12 = 1.56 \text{ IN}^2 / \text{FT.}$$

USE #8 @ 6 IN. ($A_s = 1.57 \text{ IN}^2 / \text{FT}$)

$$Q_d = \frac{1}{20} \times (\frac{60000}{\sqrt{3000}}) \times 0.79 = 42.3 \text{ IN}$$

AVAILABLE IS: 72 - 11 - 3 = 58 IN. OK.

BEARING STRESS BY FACTORED LOADS.

$$= [1.2 \times 500 + 1.6 \times 514] / 22^2 = 2940 \text{ PSI}$$

$$\phi_0 = 0.85 f_c' A_1 \sqrt{A_2/A_1} \leq 2 \phi_0.85 f_c' A_1$$

$$A_1 = 22^2 = 484 \quad A_2 = 144^2$$

$$\sqrt{\frac{144^2}{484}} = 4.2 \text{ TOO HIGH.}$$

$$\text{USE } 2 \times .45 \times 0.85 \times 3000 = 3315$$

$$3315 > 2940 \text{ REQD. } \therefore \text{OK}$$

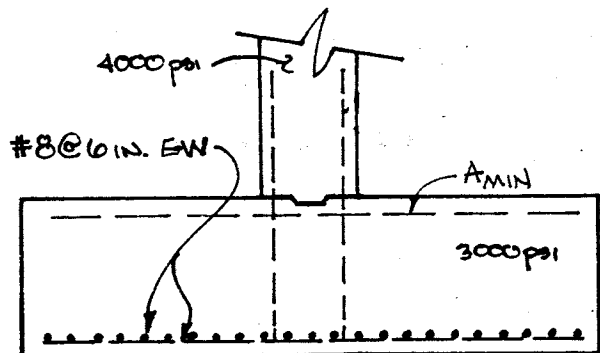

PROBLEM 16.3

$f'_c := 3000\text{psi}$

$f'_y := 60000\text{psi}$

$q_{\text{all}} := 3000\text{psf}$

$w_c := 150 \cdot \frac{\text{lb}}{\text{ft}^3}$

$P_d := 135\text{-kip}$

$P_1 := 125\text{-kip}$

$\phi_s := 0.75$

$\phi_f := 0.90$

$\phi_b := 0.65$

column $f'_c = 4000\text{ psi}$

$t := 11\text{-in}$

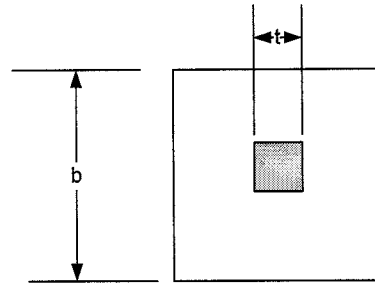

METHODOLOGY

1. Check soil bearing capacity including adjustment for footing weight.
2. Check punching shear. This check often sets the thickness of the footing.
3. Check slab shear.
4. Design flexural reinforcement.
5. Check bond and development length.
6. Check bearing stress under the column, especially if the column concrete strength is greater than the footing concrete strength.
7. Check temperature and minimum steel requirements and sketch final design.

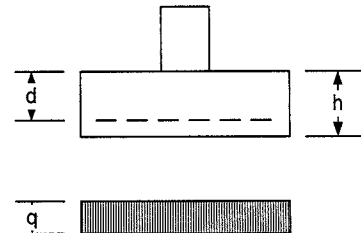

Step 1 Check soil bearing

$P := P_d + P_1 = 260\text{ kip}$

$b_{\text{trial}} := \sqrt{\frac{P}{q_{\text{all}}}} \quad b_{\text{trial}} = 9.309\text{ ft}$

This dimension does not account for the weight of the spread footing, therefore try

$b := 10\text{-ft} \quad h := 27\text{in}$ Trial thickness for weight purposes
 In addition, the development length of a No. 9 (No. 29) bar in compression is 19 in. when confined in 300 psi concrete. This depth assures dowel development

Estimate footing weight Note; this could have been done before checking the footing size. It is separated here to illustrate the use of the weight for the footing size and the non-use of the weight for strength design.

$W := w_c \cdot b^2 \cdot h = 33.75\text{ kip}$

$q := \frac{P + W}{b^2} \quad q = 2938 \frac{\text{lb}}{\text{ft}^2}$

q is equal to the 3000 psf allowable, therefore proceed with the design using a 10 ft. square footing.

Develop the factored loads for the footing design.

$$P_u := 1.2 P_d + 1.6 P_l = 362 \text{ kip}$$

Note, the weight of the footing is ignored because the concrete rests directly on the soil so there is not net shear or bending moment.

$$q_u := \frac{P_u}{b^2} = 3.62 \text{ ksf}$$

Step 2 Check Punching (two-way) Shear

Try $d := h - 4 \text{ in} \quad d = 23 \text{ in}$

4" difference between h and d reflects 3" cover and 1 to center of bars in two layers. H is less than the 36" originally used for weight so the bearing stress is OK.

$$b_o := 4 \cdot (d + t) = 136 \text{ in} \quad v_c := 4 \sqrt{f'_c \cdot \text{psi}} = 219 \text{ psi}$$

$$A_v := b_o \cdot d = 3128 \text{ in}^2$$

$$\phi V_n := \phi_s \cdot v_c \cdot A_v = 514 \text{ kip}$$

$\phi V_n > V_u = P_u = 362 \text{ kip}$, therefore the design is OK.

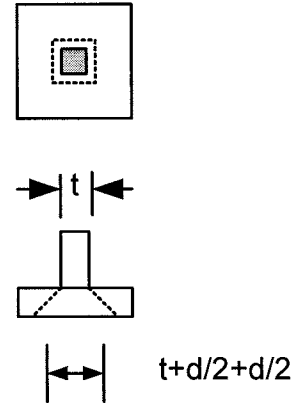

Step 3 Check One-Way Shear along the face of the footing

$$w := \frac{b}{2} - d - \frac{t}{2} = 2.625 \text{ ft} \quad V_u := q_u \cdot w \cdot b = 95 \text{ kip}$$

$$\phi V_c := 2 \phi_s \cdot \sqrt{f'_c \cdot \text{psi}} \cdot b \cdot d = 227 \text{ kip}$$

Nominal shear capacity exceeds the ultimate load, therefore, one way shear is OK

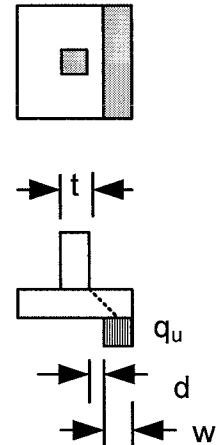

Step 4 Flexural Design

While the shear may be computed at a location d from the face of the column, the flexural design must be computed at the face of the column.

$$l := \frac{b}{2} - \frac{t}{2} = 4.54 \text{ ft} \quad M_u := \frac{q_u \cdot l^2}{2} = 448 \frac{1}{\text{ft}} \text{ in} \cdot \text{kip} \quad \text{try} \quad a := 2 \cdot \text{in}$$

$$A_s := \frac{M_u}{\phi_f \cdot f_y \cdot \left(d - \frac{a}{2}\right)} = 0.377 \frac{\text{in}^2}{\text{ft}} \quad A_{s6} := 0.44 \text{ in}^2$$

$$s := \frac{A_{s6}}{A_s} \cdot 12 \cdot \frac{\text{in}}{\text{ft}} \quad s = 14.0 \text{ in}$$

Try #6 @ 14 in. A_s provided = 0.33 in²/ft

Check "a"

$$\frac{0.33 \cdot \text{in}^2 \cdot f_y}{.85 \cdot f_c \cdot 12 \cdot \text{in}} = 0.65 \text{ in} < a \text{ assumed, OK}$$

The estimate for "a" could be refined, but as will be seen later, the refinement is not necessary at this time.

Step 5 Check Bond and Development

The development length must be less than the portion of the slab extending beyond the face of the column.

#6 bottom bar from table A.10, $l_d/d_b = 38$ $d_b := 0.75 \cdot \text{in}$ $c := 3 \cdot \text{in}$

$$l_d := 38 \cdot d_b \quad l_d = 28.5 \text{ in} < \frac{b}{2} - \frac{t}{2} - c = 51.5 \text{ in}$$

Therefore the development length is OK

Step 6 Check Column Bearing Stress on Footing

Column and footing do not have the same strength, therefore an additional check is needed.

The building code allows for the effective bearing area in the footing to be increased assuming a 2:1 spread in load, however, the maximum ratio of increase is limited to 2. ACI 2008 Section 10.14. Try basic column area first.

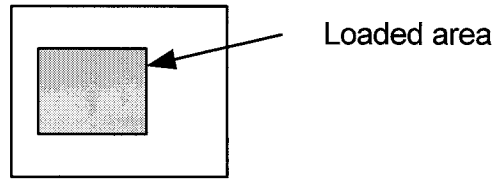

$$f_{ball} := 0.85 \cdot f_c \cdot \phi_b \quad f_{ball} = 1658 \text{ psi}$$

Using the increased allowable area for bearing

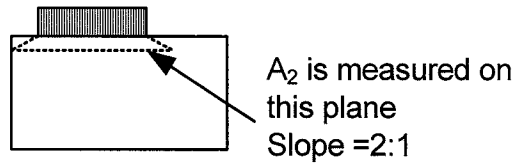

$$f_b := \frac{P_u}{2t^2} = 1496 \text{ psi} \quad \text{Bearing stresses are OK.}$$

Step 7 Check temperature and minimum reinforcement

$$A_{st} := 0.0018 \cdot h \quad A_{st} = 0.583 \frac{1}{\text{ft}} \text{ in}^2$$

Temperature reinforcement is less than provided, therefore OK

Minimum reinforcement is greater than provided. Increase reinforcement to #6 @ 9 in.

$$A_s := 0.44 \text{ in}^2 \cdot \frac{12 \text{ in}}{9 \text{ in}} = 0.587 \text{ in}^2$$

Final Detailing

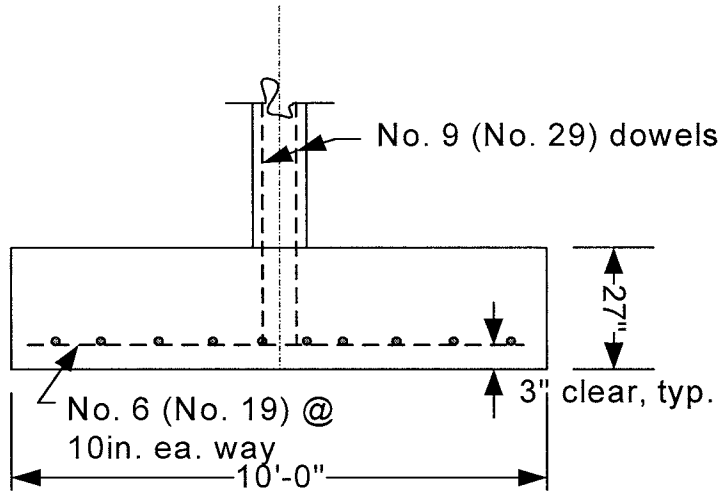

16.4 FOOTING DESIGN

$$P_0 = 1.2D + 1.6L = 1.2(500) + 1.6(514) = 1422 \text{ KIPS}$$

LONG SIDE = 2 x SHORT SIDE.

ASSUME AVG UNIT WEIGHT = 125 PCF

$$Q_{EFF} = 8000 - (6 \times 125) = 7750 \text{ PSF}$$

$$A_{REQD} = \frac{2 \times 500 + 2 \times 514}{7.25} = 280 \text{ SQ FT}$$

X = SHORT DIRECTION.

$$X(2X) = 2X^2 = 280. \quad X = 11.8 \text{ FT.}$$

FOOTING IS 12 FT x 24 FT.

$$q_u = \frac{1}{288} \times [1.2 \times 1000 + 1.6 \times 1028] = 9.88 \text{ KSF.}$$

DRAW V & M DIAG. FOR LONGITUDINAL DIR.

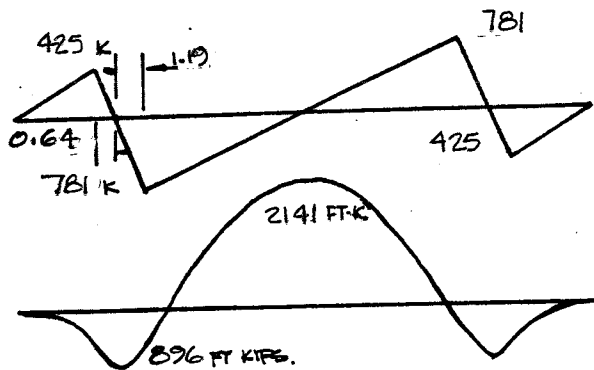
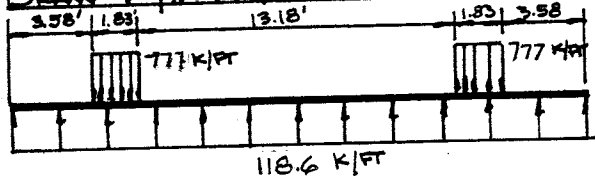

DESIGN OF LONGITUDINAL STEEL

TRY $d = 36 \text{ IN.}$

$$V_u = 781 - \left(\frac{36}{12} \times 118.6\right) = 425 \text{ KIPS}$$

$$V_d = .75 \times 2 \times \sqrt{3000} \times 144 \times 36 = 426 \text{ KIPS.}$$

SO, $426 > 425$ OK!

CHECK PUNCHING SHEAR

$$V_u = \text{COL. LOAD} - \text{SOIL PRESS. w/IN. PERIM.}$$

$$= 1422 - \frac{(22+36)^2}{12 \times 12} \times 9.88 = 1191 \text{ K.}$$

$$V_d = .75 \times 4 \times \sqrt{3000} \times 232 \times 36 = 1372 \text{ K. OK.}$$

$$\text{TOTAL FOOTING THICKNESS: } 36 + 3\frac{1}{2} = 40 \text{ IN}$$

STEEL FOR NEG. MOMENT REGION

$$M_u / \phi b d^2 = 25,700 / .9 \times 144 \times 36^2 = 153 \quad \rho < \rho_{min}$$

$$\rho_{min} = 0.0033.$$

$$A_{REQD} = 0.0033 \times 144 \times 36 = 17.26 \text{ IN}^2.$$

$$\text{USE } \#11 @ 12 \text{ IN. } A_s = 17.19 \text{ IN}^2.$$

$$l_d = \frac{1}{54.77} \times 0.04 \times 1.4 \times 1.56 \times 60000 = 96 < 14 \text{ IN. OK.}$$

USE SAME STEEL IN POS. MOM. REGION

$$\#11 @ 12 \text{ IN.}$$

$$l_d = \frac{1}{54.77} \times 0.04 \times 1.56 \times 60000 = 69 > 43,$$

SO MUST USE HOOK AT END.

DESIGN OF TRANSVERSE STEEL (UNDER COLUMNS)

$$\text{EFF. WIDTH OF TRANS. BEAM} = 22 + d = 58 \text{ IN.}$$

$$\text{NET UPWARD LOAD} = 1422 / 12 \text{ FT} = 118.6 \text{ K/FT.}$$

$$M @ \text{COL. FACE} = 118.6 \left(\frac{5.08^2}{2}\right) = 1530 \text{ KFT.}$$

$$d = 36 - 1\frac{1}{2} = 34\frac{1}{2} \text{ IN.}$$

$$M_u / \phi b d^2 = 295 \quad \rho = 0.0052$$

$$A_{REQD} = 0.0052 \times 58 \times 34.5 = 10.4 \text{ IN}^2.$$

$$\text{USE } 7 \text{ } \#11 @ 8 \text{ IN. } A_s = 10.9 \text{ IN}^2$$

$$l_d = 69 \text{ IN (AS BEFORE)}$$

$$\text{AVAIL. LENGTH} = 5.08 \times 12 = 58 \text{ IN} < 69$$

SO HOOK BOTH ENDS.

CHECK BEARING OF COLUMN ON FOOTING

$$V_d = 2 \times .85 \times 3000 \times 22^2 \times .65 = 1604 \text{ KIPS}$$

$$V_u = 1.2 \times 500 + 1.6 \times 514 = 1422 < 1604 \text{ OK.}$$

$$A_{min} = 0.005 \times 22^2 = 2.42 \text{ IN}^2$$

USE 4-#11 GO ALL SAME DIAM. BARS.

$$l_{d \text{ col}} = 30 \text{ IN} \quad l_{d \text{ FTG}} = 34 \text{ IN.}$$

- BEND BOTTOMS FOR CONSTRUCTION.

16.5 $f'_c = 4000 \text{ psi}$, for column
 $f'_c = 3000 \text{ psi}$, for footing
 $f_y = 60,000 \text{ psi}$

$P_U = 1.2(285) + 1.6(570) = 1248 \text{ K}$
 $P_{u,pile} = P_U/9 = 1248/9 = 139 \text{ K}$

Design depth for shear across length of footing

$V_u = 3P_{u,pile} = 3(139) = 417 \text{ K}$

$\phi V_c = \phi 2\sqrt{f'_c} b d \geq V_u$

$d = \frac{V_u}{\phi 2\sqrt{f'_c} b} = \frac{417}{0.75(2)\sqrt{3000} 9 \times 12}$

$d = 47.0 \text{ in}$

Use $d = 48.0 \text{ in}$, $h = 48 + 9 + 1 = 58 \text{ in}$

Check Punching shear

$V_U = P_U = 1248 \text{ K}$

$\phi V_c = \phi 4\sqrt{f'_c} b_o d$

$b_o = 4(d + 19) = 4(48 + 19) = 268 \text{ in}$

$\phi V_c = 0.75(4) \frac{\sqrt{3000}}{1000} 268(48)$

$\phi V_c = 2114 \text{ K} > V_u \text{ OK}$

Check Pile punching: There will be an overlapping of all eight exterior shear parameters. The shear envelop almost coincides with the column perimeter. Thus, no need to check as loads will be directly transferred.

DESIGN FLEXURAL REINFORCEMENT

M AT COLUMN FACE

$M_U = 3(139) \left(3 - \frac{19}{12} \right) = 921 \text{ FT-KIP}$

$\frac{M_U}{\phi b d^2} = \frac{921(12000)}{.9(9 \times 12) 48^2} = 49 \text{ USE } \rho_{min}$

$\rho_{min} = \frac{200}{f_y} = 0.0033$

$A_s = \rho b d = 0.0033(9 \times 12) 48 = 17.1 \text{ in}^2$

USE 11 #11 (#39) at 8" $A_s = 17.2 \text{ in}^2$

CHECK DEVELOPMENT

$l_d = \frac{f_y}{20\sqrt{f'_c}} \frac{d_b}{20\sqrt{3000}} (1.41) = 77.2 \text{ in}$

AVAILABLE LENGTH = $\frac{9 \times 12}{2} - \frac{19}{2} - 3 = 42 \text{ in}$

USE STANDARD HOOK

BEARING STRESS AT BASE OF COLUMN

$A_1 = 21^2 = 441 \text{ in}^2$

$A_2 = (6 \times 12)^2 = 5184 \text{ (to } \phi \text{ piles)}$

$\sqrt{\frac{A_2}{A_1}} = \sqrt{\frac{5184}{441}} = 3.4 \text{ USE 2. per code}$

$F_B = \phi .85 f'_c A_1 \sqrt{\frac{A_2}{A_1}} = 0.65(.85) 3000(36)^2$

$= 1196 \text{ K}$

$P_U = 1248 \text{ K} > F_B$

Need EXTRA REINFORCEMENT

$F = P_U - F_B = 1248 - 1196 = 52 \text{ K}$

$A_{min} = 0.005 \text{ WILL PROVIDE}$

$A_{min} = 0.005(19)^2 = 1.81 \text{ in}^2$

USE SAME BARS

4#11 (1 IN EACH CORNER)

$A_s = 5.08 \text{ in}^2$

$l_d = \frac{0.02 f_y d_b}{\sqrt{f'_c}} > 0.0003 f_y d_b$

COLUMN

$l_d = \frac{.02(60000)1.41}{\sqrt{4000}} = 26.8 \text{ in}$

$> .0003(60000)1.41 = 25.0 \text{ in}$

FOOTING

$l_d = .02 \frac{60000(1.41)}{\sqrt{3000}} = 31 >$

$.0003(60000)1.41 = 25.4$

16.5 - $f'_c = 3000 \text{ psi}$ $f_y = 60,000 \text{ psi}$

from Fig 16.19 $q_u = 7.06 \text{ k/ft}^2$

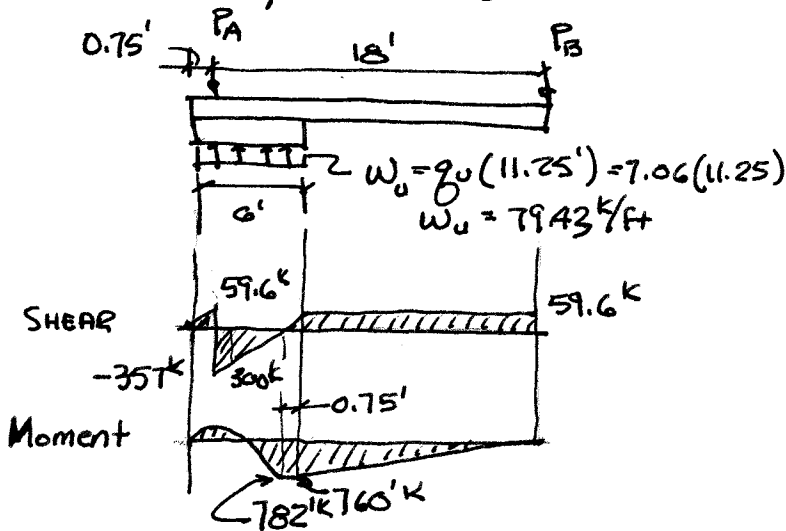

Find Reactions

$$\sum M_B = 0 = P_A(18) - w_u(6')(18' + 7.5' - \frac{6}{2})$$

$$P_A = 417 \text{ k}$$

$$\sum F_y = 0 = P_A + P_B - w_u(6)$$

$$P_B = 59.6 \text{ k}$$

Critical moment is 0.75' inside the footing

$$M_u = 782 \text{ kips}$$

Critical shear is at the face of the column

$$V_u = 300 \text{ k}$$

Assume trial depth $h = 65"$, $d = 60"$, $b = 30"$

$$\frac{M_u}{\phi b d^2} = \frac{782(12000)}{0.9(30)(60)^2} = 96.5 \text{ Req'd } \rho < \rho_{min}$$

Use $\rho = 0.0035 > \rho_{min}$ $R = 201$ (Table A.5a)

$$d^2 = \frac{M_u}{\phi b R} = \frac{782(12000)}{0.9(30)201} = 1729 \text{ in}^2$$

$$d = 41.5 \quad h = 41.5 + 3 \text{ cover} + 1" + 5 \text{ stirrup} = 46 \text{ in}$$

check shear at face of footing

$$\phi V_n = \phi 2 \sqrt{f'_c} b_w d = 0.75(2) \sqrt{\frac{3000}{1000}} 30(41.5) = 102.3 \text{ k}$$

$V_u < \phi V_n \therefore$ Need only minimum shear reinforcement between face of ftg and P_B

Assume #4 stirrups

$$s_{max} = \begin{cases} d/2 = 41.5/2 = 20.75 \text{ in} \\ 24 \text{ in} \\ \frac{A_v f_y}{50 b_w} = \frac{2(.20)60000}{50(30)} = 16 \text{ in} \leftarrow \end{cases}$$

Use #4 (#13) at 16 in

Flexural reinforcement

$$A_s = \rho b d = 0.0035(30)(41.5) = 4.36 \text{ in}^2$$

$$\text{Use } 3 \#11 (\#36) \quad A_s = 4.68 \text{ in}^2$$

(con't.)

16.5 (cont.)

DESIGN BEAM ABOVE FOOTING AT A WITH STRUT AND TIE MODEL

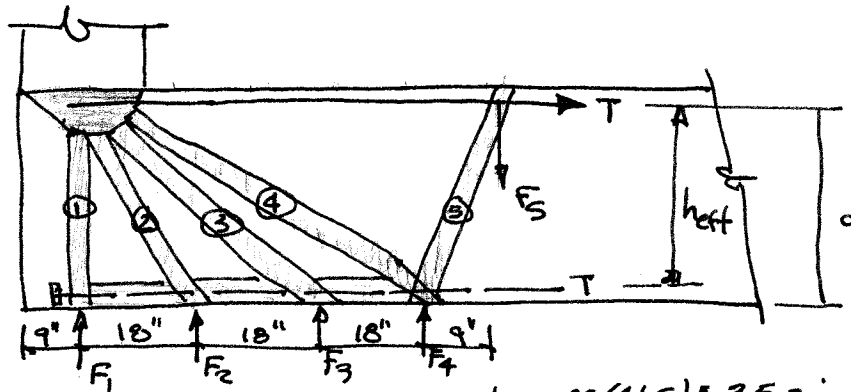

$d = 41.5''$ Assume $h_{eff} = 0.85d = 0.85(41.5) = 35.3$ in

Space distributed load at 1.5' c-c $F_1 = F_2 = F_3 = F_4 = 1.5(79.43) = 119$ k

$F_5 = \text{shear from B} = 59.6$ k

Node capacity at CCT node $\beta_n = 0.80$ $f_{un} = \phi \beta_n \cdot 85 f_c' = .75(.8) \cdot 85(3) = 1.53$ ksi

Bottle shaped strut capacity $\beta_s = 0.75$ $f_{us} = \phi \beta_s \cdot 85 f_c' = .75(.75) \cdot 85(3) = 1.43$ ksi

STRUT	$\theta = \tan^{-1} \frac{h}{x}$	V_u	$P_u = \frac{V_u}{\sin \theta}$	$w = \frac{P_u}{f_{us} \cdot b}$	$H = P_u \cos \theta$
1	90	119 k	119 k	2.8"	0 k
2	63.0	119 k	134 k	3.1"	61 k
3	44.4	119 k	170 k	4.0"	121 k
4	33.2	178.6 k	327 k	7.6"	274 k
5	75.7	59.6 k	61.5 k	1.4"	15 k

$\Sigma H = 471$ k

Check compression strut width with $\beta_s = 1.0$

$w = \frac{\Sigma H}{\phi \beta_s \cdot 85 f_c' \cdot b} = \frac{471}{.75(1) \cdot 85(3) \cdot 30} = 8.2$ in

$h = d - \frac{w}{2} = 41.5 - \frac{8.2}{2} = 37.4 > \text{assumed ok}$

DESIGN TIE

$A_s = \frac{\Sigma H}{\phi f_y} = \frac{471}{0.75(60)} = 10.47$ in²

Use 7-#11 (#36) bars $A_s = 10.9$ in² $l_d = 77$ in (top bar) = 6'-6"

Run 4 bars one development length past the end of the footing.

Run 3 bars full length for moment from column at B.

Hook bars at A & B end.

Run 7-#11 (#36) bars on bottom of footing to pick up the unbalanced compression strut at F_1 .

CHECK STRESS AT COLUMN A

$p = \frac{P}{A} = \frac{417}{18 \times 24} = 0.97$ ksi $< f_{un} \therefore \text{OK}$

(cont.)

16.6 (CON'T.)

DESIGN MINIMUM SHEAR REINFORCEMENT

$$A_v = 0.0025 b_s = .0025(30)(12) = 0.90 \text{ in}^2/\text{ft}$$

$$\text{Use } \#4(\#13) \square @ 5 \text{ in } A_s = 0.96 \text{ in}^2/\text{ft}$$

$$A_H = 0.0015 b_s = .0015(30)(12) = 0.54 \text{ in}^2/\text{ft}$$

$$\text{Use } \#4(\#13) @ 8 \text{ in ea. face } A_s = 0.60$$

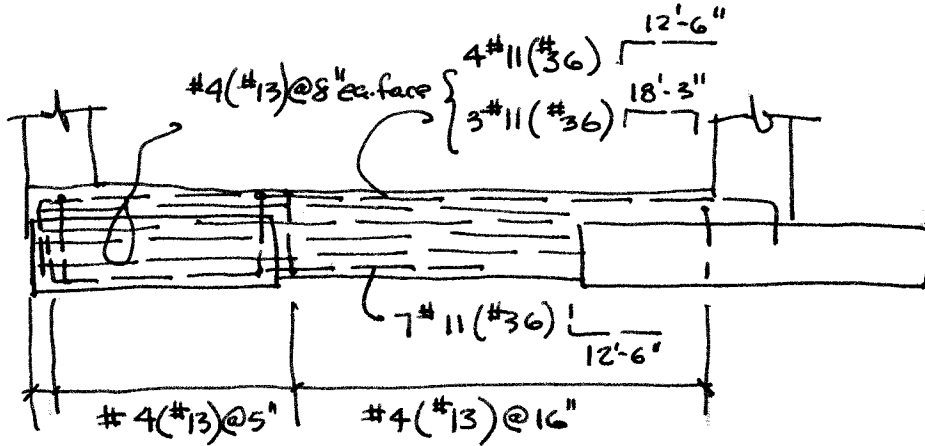

COMPARE CONCRETE VOLUMES

STRAP FOOTING

$$6 \times 11 \times 1.5 = 99$$

$$9 \times 9 \times 1.0 = 81$$

$$\frac{30 \times 46}{144} (8.25) = 79$$

$$\frac{30 \times 29}{144} (3.5) = 21$$

$$\frac{30 \times 28}{144} (4.0) = 23$$

$$\hline 303 \text{ cu ft}$$

COMBINED FTG

$$6.5 (23.25) (3.42) = 517 \text{ cu ft}$$

$$\text{STRAP FOOTING CONTAINS } \frac{303}{517} = 0.59 \text{ or } 59\% \text{ AS MUCH}$$

CONCRETE.

17.1 BASED ON PRELIMINARY TRIALS SELECT THE FOLLOWING DIMENSIONS

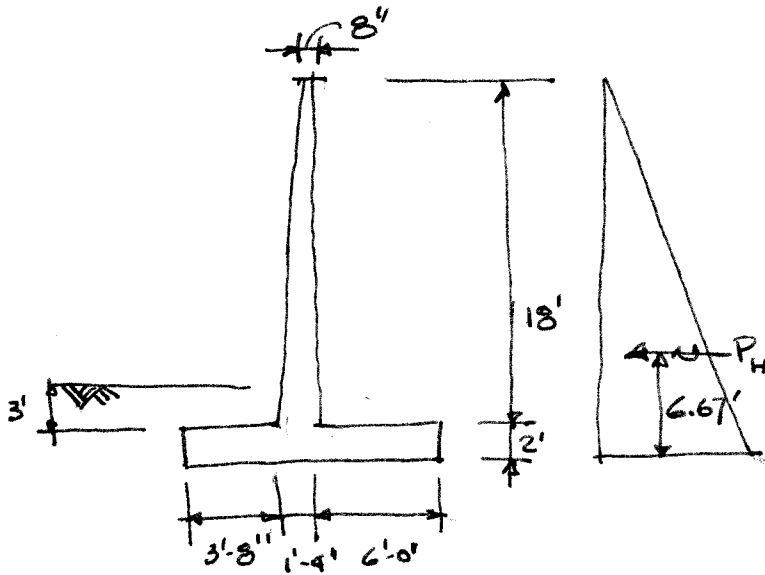

$$f'_c = 4000 \text{ psi}$$

$$f_y = 60,000 \text{ psi}$$

$$\gamma_s = 120 \text{ pcf}$$

$$\phi = 33^\circ$$

$$f = 0.55$$

$$K_A = \frac{1 - \sin \phi}{1 + \sin \phi} = 0.295$$

$$K_P = \frac{1 + \sin \phi}{1 - \sin \phi} = 3.39$$

$$W = 120(6)18 + 150(1)18 + 150(2)11 =$$

$$W = 18960 \text{ lb}$$

$$M_e = 120(6)18(8) + 150(1)18(4.33) + 150(2)(11)\frac{11}{2}$$

$$= 133500 \text{ ft-kip}$$

STABILITY

$$P_H = \frac{1}{2} K_A \gamma h^2 = \frac{1}{2} (0.295) 120 (20)^2 = 7080 \text{ lb}$$

$$M_o = P_H \bar{y} = 7080 (6.67) = 47200 \text{ ft-lb}$$

$$a = \text{dist to resultant from toe} = \frac{133500 - 47200}{18960} = 4.55' \text{ (WITHIN MIDDLE } \frac{1}{3} \text{)}$$

$$q_{\text{max}} = \frac{W}{A} \pm \frac{M_c}{I} = \frac{18960}{1(11)} \pm \frac{18960(5.5 - 4.55)}{(1)(11)^2/6} = \begin{cases} 2617 \text{ psf} \\ 830 \text{ psf} \end{cases}$$

CHECK SLIDING

$$\text{Resistance} = Wf = 18960(0.55) = 10,428$$

$$SF = \frac{R}{P_H} = \frac{10428}{7030} = 1.47 \approx 1.5 \text{ OK no key necessary}$$

passive pressure at the toe not counted. WITH 2' PASSIVE PRESSURE FS = 1.59.

CHECK OVERTURNING

$$SF = \frac{M_r}{M_o} = \frac{133500}{47200} = 2.83 > 1.5 \text{ OK}$$

STRUCTURAL DESIGN - TOE $d = 24'' - 3'' - 1'' = 20''$

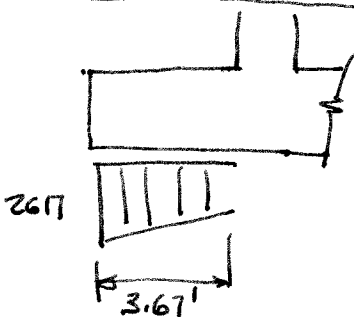

NEGLECT DOWNWARD EFFECT OF SOIL
ASSUME ALL LOAD TO BE LIVE LOAD

$$V_u = 1.6(2617)3.67 = 15,400 \text{ lb}$$

$$\phi V_c = 0.75(2)\sqrt{4000}(12)20 = 22,800 \text{ lb}$$

$$\phi V_c > V_u \text{ OK}$$

(CON'T.)

17.1 (CON'T.)

$$M_u = 1.78 L^2/E = 1.7(2617) 3.67^2 = 29,960 \text{ ft}\cdot\text{lb}$$

$$R = \frac{M_u}{\phi b d^2} = \frac{29,960(12)}{0.9(12)(20)^2} = 83 \quad \rho < \rho_{min}$$

USE $\rho = \rho_{min} = 0.0033$

$$A_s = 0.0033(12)20 = 0.79 \text{ in}^2/\text{ft}$$

USE #8 @ 12 in $A_s = 0.79 \text{ in}^2/\text{ft}$

$$l_d = \frac{f_y \alpha \beta \gamma \lambda}{d_b 20 \sqrt{f_c'}} = \frac{60000(1)(1)(1)(1)}{20 \sqrt{4000}} = 47.4$$

$$l_d = 47.4(1) = 47.4$$

EXTEND #8 (#25) 4'-0" BEYOND FACE OF WALL

HEEL DESIGN

$$M_u = 1.2(150)(2)(6)\frac{6}{2} + 1.6(120)18(6)\frac{6}{2} = 68,700 \text{ ft}\cdot\text{lb}$$

$$V_u = 1.2(150)2 + 1.6(120)18(6) = 21,100 \text{ lb}$$

$$\phi V_c = 0.75(2)\sqrt{4000}(12)(20) = 22,800 \text{ lb}$$

$\phi V_c > V_u$ OK

$$R = \frac{M_u}{\phi b d^2} = \frac{68,700(12)}{0.9(12)(20)^2} = 191$$

$$\rho = 0.0033 \approx \rho_{min} = 0.0033$$

$$A_s = 0.0033(12)20 = 0.79 \text{ sq in/ft}$$

USE #8 (#25) AT 12 in C-C. OR #7 (#22) AT 9 in

Top bars so $l_d = 48(1.3) = 62 \text{ in}$

$$l_d = \frac{60000(1.3)(1.85)}{20 \sqrt{4000}} = 54 \text{ in} \quad \neq \text{No Hook}$$

AVAIL length = 1'-4" + 3'-8" = 5'-0" \therefore HOOK TOP BARS AT TOE

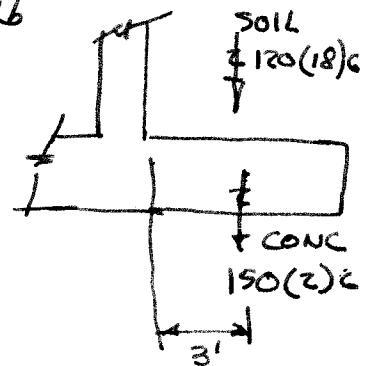

ARM DESIGN

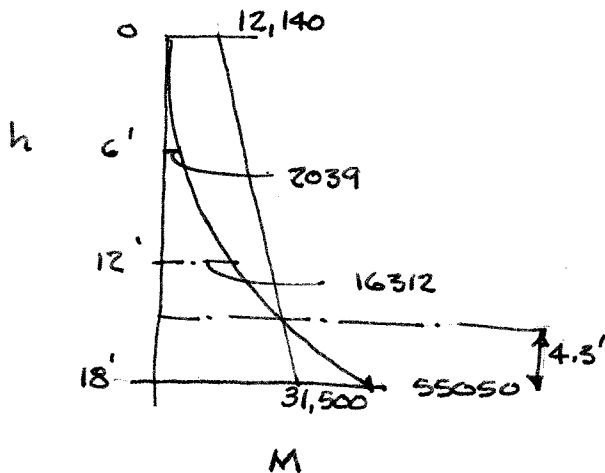

At BASE

$$M_u = \left(\frac{1}{2} k_1 w h^2\right) \frac{h}{3} \cdot 1.6 = \frac{.295}{2} 120(18)^2 \frac{18}{3} (1.6)$$

$$M_u = 55,050 \text{ ft}\cdot\text{lb}$$

$$M_{u,6} = 2039 \text{ ft}\cdot\text{lb}$$

$$M_{u,12} = 16,312 \text{ ft}\cdot\text{lb}$$

$$d \text{ at base} = 16 - 2 - 0.5 = 13.5 \text{ in}$$

$$d \text{ at top} = 8 - 2 - 0.5 = 5.5 \text{ in}$$

(CON'T.)

17.1 (CON'T.)

DESIGN BASE OF ARM

$$R = \frac{M_u}{\phi b d^2} = \frac{55090(12)}{0.9(12)(13.5)^2} = 336$$

$$\rho = 0.0059$$

$$A_s = 0.0059(12)(13.5) = 0.96 \text{ in}^2$$

USE #8 (#25) @ 9 in $A_s = 1.05 \text{ in}^2$

CUT OFF ALT. BARS

$$A_s = 0.53 \text{ in}^2/\text{ft}$$

$$\text{AT BASE } \rho = \frac{0.53}{12(13.5)} = 0.0033 \quad R = 192$$

$$M_u = \phi R b d^2 = 0.9(192)12(13.5)^2/12 = 31,500 \text{ ft-lb}$$

$$\text{AT TOP } \rho = \frac{0.53}{12(5.5)} = 0.0080 \quad R = 446$$

$$M_u = 0.9(446)(12)(5.5)^2/12 = 12,140 \text{ ft-lb}$$

$M_u \approx \phi M_u$ 4.3' FROM BASE = THEORETICAL CUTOFF

$$\text{ACTUAL CUTOFF} = 4.3 + 12d_b \text{ or } d = 4.3 + 1 = 5.3'$$

CUT BARS AT 5'-4" ABOVE BASE.

$$\text{BAR SPLICE LENGTH} = 1.3 \ell_d = 1.3(47.4) = 61.6 \text{ in} < 5'-4" \text{ OK}$$

CHECK SHEAR AT CUTOFF

$$V_u = \frac{1}{2}(120 \times 1.6) \left(18 - 5.3 \right)^2 \cdot 295 = 4568 \text{ lb}$$

$$d = 11.1 \text{ in}$$

$$V_c = \phi 2 \sqrt{f_c} b d = 0.75(2) \sqrt{4000} 12 \times 11.1 = 12,636 \gg V_u \text{ OK}$$

CHECK MINIMUM REINF AT CUTOFF

$$\rho = \frac{A_s}{b d} = \frac{0.53}{12(11.1)} = 0.00398 > \rho_{\min} \text{ OK}$$

TEMPERATURE STEEL

$$\text{ARM VERTICAL } \cdot 0.0012(12 \times 12) = 0.17 \text{ in}^2/\text{ft}$$

SPACING < 18" \therefore USE #3 BAR
HORIZONTAL

$$A_s = 0.0020(12)12 = 0.29 \quad \#3(\#10) @ 9" \text{ EA FACE}$$

#4(#13) AT 28 in
#3(#10) AT 15 in

$$\text{BASE } 0.0012(12 \times 20) = 0.29 \quad \#4(\#13) \text{ AT } 10 \text{ in}$$

(CON'T.)

17.1 (CON'T.) FINAL DESIGN

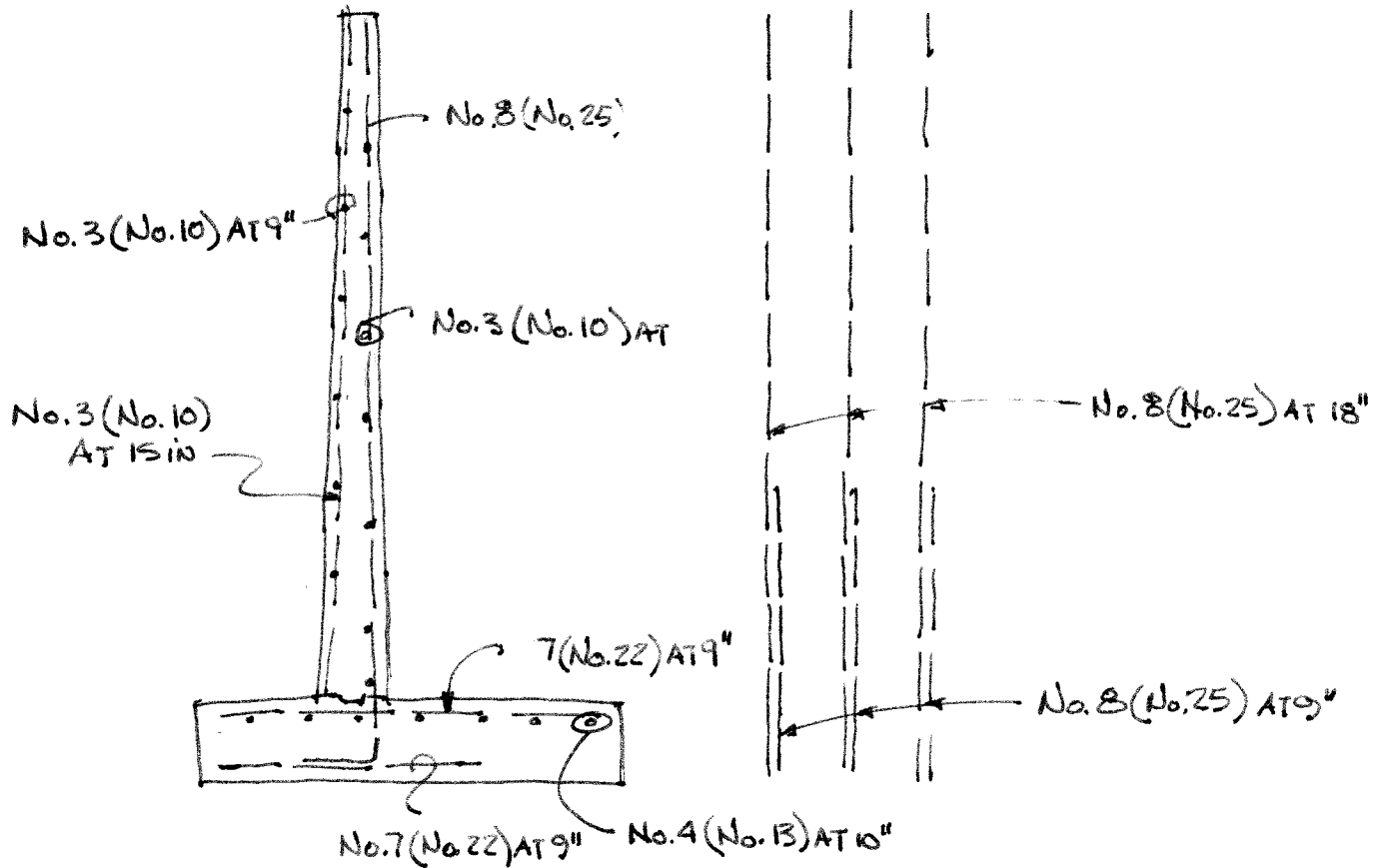

NOTE: THE ORIGINAL BAR SELECTION USED No. 8 (No. 25) BARS, BUT WAS REDUCED TO No. 7 (No. 22) TO MEET BOND REQUIREMENTS AND AVOID HOOKS ON HEEL AND TOE. THE ECONOMICS OF STRAIGHT BARS OUTWEIGHS THE PLACEMENT COSTS OF FEWER No. 8 (No. 25) HOOKED BARS. IN EITHER CASE A HOOK IS NEEDED FOR THE ARM/FOOTING JOINT

17.2

STABILITY INVESTIGATION OF COUNTERFORT WALL IS THE SAME AS FOR THE CANTILEVER WALL EXCEPT FOR THE WEIGHTS.

DESIGN OF VERTICAL WALL AND HEEL IS BEST DONE WITH HILLERBORG STRIP METHOD. ONE LAYOUT IS SHOWN.

THE TOE IS DESIGNED AS A SIMPLE CANTILEVER AS IN PROB. 17.1. THE BUTTRESS FOR THE COUNTERFORT CAN BE DESIGNED AS A STRUT AND TIE MODEL.

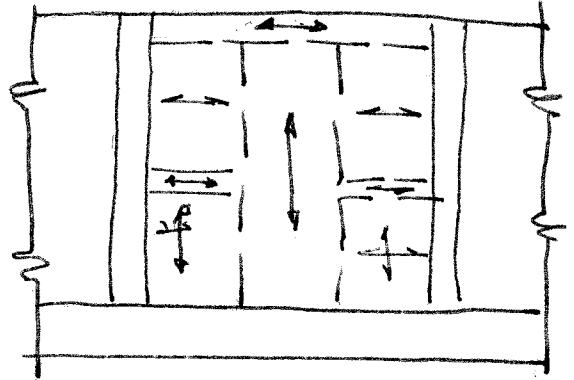

USING THE COUNTERFORT DESIGN WILL INCREASE THE FORMING COSTS AND DECREASE CONCRETE AND STEEL COSTS. SAVINGS OF 15-20% COMPARED TO THE CANTILEVER.

STRIPS FOR HILLERBORG METHOD - WALL

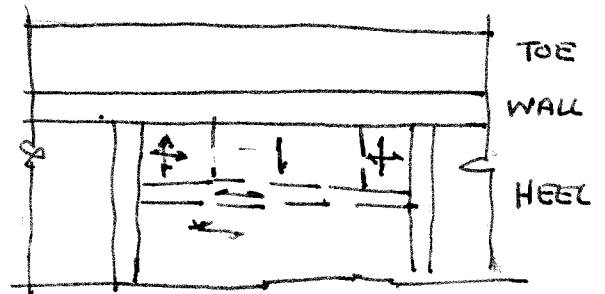

STRIPS FOR HILLERBORG METHOD - Heel

19.1

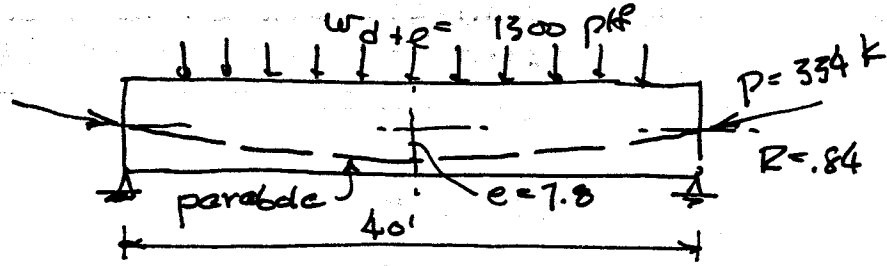
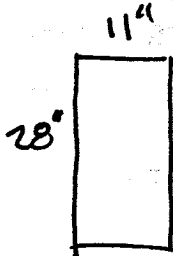

$A_c = 308 \text{ in}^2$ $I_c = 20122 \text{ in}^4$ $r^2 = 65.3 \text{ in}^2$ $c = 14 \text{ in}$ $S = 1437 \text{ in}^3$

(a) P_{Si} : $f_1 = -\frac{334}{308} \left(1 - \frac{7.8 \times 14}{65.3}\right) = +728 \text{ psi}$ $M_0 = 768 \text{ in-k}$
 $f_2 = -2897 \text{ psi}$ $w_0 = 320 \text{ plf}$
 W_0 : $f_1 = 768000 / 1437 = -534 \text{ psi}$
 $f_2 = +534 \text{ psi}$
 $P_{Si} + W_0$: $f_1 = +728 - 534 = +194 \text{ psi}$
 $f_2 = -2897 + 534 = -2363 \text{ psi}$

(b) P_{Se} : $f_1 = +728 \times .84 = +612 \text{ psi}$
 $f_2 = -2897 \times .84 = -2433 \text{ psi}$
 $M_{d+l} = 3120 \text{ in-k}$
 W_{d+l} : $f_1 = 3120000 / 1437 = -2171 \text{ psi}$
 $f_2 = +2171 \text{ psi}$

$P_{Se} + W_0 + W_{d+l}$: $f_1 = +612 - 534 - 2171 = -2093 \text{ psi}$
 $f_2 = -2433 + 534 + 2171 = +272 \text{ psi}$

COMPARE WITH ACI ALLOWABLES:

$f_{ci} = .6 f'_c = .6 \times 4000 = -2400 \text{ psi} > -2363 \text{ OK}$
 $f_{tc} = 3 \sqrt{f'_c} = 3 \times \sqrt{4000} = +190 \text{ psi} \approx +194 \text{ OK}$
 $f_{ts} = 6 \sqrt{f'_c} = 6 \sqrt{5000} = +424 \text{ psi} > +272 \text{ OK}$
 $f_{cs} = .45 f'_c = .45 \times 5000 = -2250 \text{ psi} > -2093 \text{ OK}$

19.2

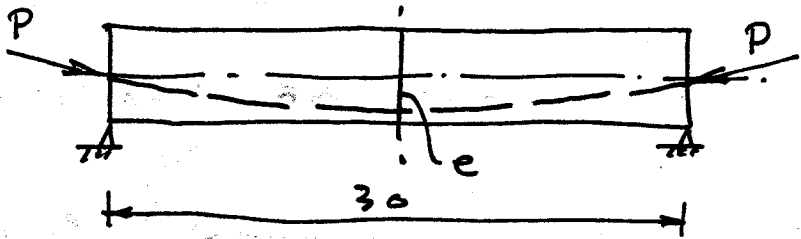
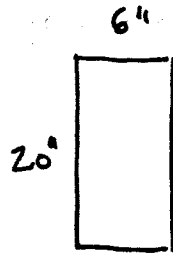

$$A_c = 120 \text{ in}^2 \quad I_c = 4000 \text{ in}^4 \quad S = 400 \text{ in}^3 \quad r^2 = 33.3 \text{ in}^2$$

$$R = 1.80 \quad f_{tc} = +165 \text{ psi} \quad f_{ci} = -1800 \text{ psi}$$

$$f_{ts} = +380 \text{ psi} \quad f_{cs} = -1800 \text{ psi}$$

$$w_o = 125 \text{ plf}$$

$$M_o = 14000 \text{ ft-lb}$$

$$f_1 = f_2 = 420 \text{ psi from } M_o$$

FOR INITIAL CONDITIONS:

$$f_1 = -\frac{P_i}{A_c} \left(1 - \frac{ec}{r^2}\right) - \frac{M_o}{S} = 165$$

$$f_2 = -\frac{P_i}{A_c} \left(1 + \frac{ec}{r^2}\right) + \frac{M_o}{S} = -1800$$

SOLVE SIMULTANEOUSLY
TO OBTAIN:

$$P_i = 98100 \text{ lb}$$

$$e = 5.71 \text{ in}$$

CHECK:

$$P_i: \quad f_1 = -\frac{98100}{120} \left(1 - \frac{10 \times 5.71}{33.3}\right) = +584 \text{ psi}$$

$$f_2 = -\frac{98100}{120} \left(1 + \frac{10 \times 5.71}{33.3}\right) = -2219 \text{ psi}$$

$$P_i + w_o: \quad f_1 = +584 - 420 = +164 \text{ psi} \approx +165 \text{ OK}$$

$$f_2 = -2219 + 420 = -1799 \text{ psi} \approx -1800 \text{ OK}$$

$$\text{THEN } P_e: \quad f_1 = +584 \times 1.8 = +467 \text{ psi}$$

$$f_2 = -2219 \times 1.8 = -1775 \text{ psi}$$

STRESS RANGE AVAILABLE:

$$\text{FOR } M_{d+e}: \quad f_1 = 1800 + 467 - 420 = 1847 \text{ psi}$$

$$f_2 = 1775 + 380 - 420 = 1735 \text{ psi}$$

$$\therefore \frac{M_{d+e}}{S} = 1735 \quad M_{d+e} = 1735 \times \frac{400}{12} = 57800 \text{ ft-lb}$$

$$w_{d+e} = \frac{8 \times 57800}{900} = \boxed{514 \text{ plf}}$$

USE TENDON DEFLECTED AT $L/3$ FOR APPROX. PARABOLA.

19.3

A. BEAM WITH STRAIGHT STRANDS :ASSUME $w_o = 500$ plf $M_o = 189$ ft-k $R = .80$

$$M_d = 227$$

$$M_e = 454$$

$$f_{ti} = 6\sqrt{f'_{ci}} = 329 \text{ psi (SUPT)} \quad f_{ts} = 12\sqrt{f'_{ci}} = 849 \text{ psi}$$

$$f_{ti} = 3\sqrt{f'_{ci}} = 164 \text{ psi (SPAN)} \quad f_{cs} = .45 f'_{ci} = 2250 \text{ psi}$$

$$f_{ci} = .6 f'_{ci} = 1800 \text{ psi}$$

$$S_1 \geq \frac{M_o + M_d + M_e}{R f_{ti} - f_{cs}} = 4153 \text{ in}^3 \quad S_2 \geq \frac{M_o + M_d + M_e}{f_{ts} - R f_{ci}} = \underline{\underline{4560 \text{ in}^3}}$$

FOR STATED PROPORTIONS $h = 39.76$ " SAY 40 "

$$A_c = 512 \text{ in}^2 \quad I_c = 92851 \text{ in}^4 \quad S = 4643 \text{ in}^3$$

CHECK $w_o = 533$ plf ≈ 500 OK

$$f_{cci} = f_{ti} - \frac{c_i}{h} (f_{ti} - f_{ci}) = 736 \text{ psi}$$

$$P_i = A_c f_{cci} = 377 \text{ k}$$

$$e = (f_{ti} - f_{ci}) \frac{S_1}{P_i} = 13.1$$

CHECK MIDSPAN TENSION :

$$f_1 = -\frac{P_i}{A_c} \left(1 - \frac{ec}{r^2}\right) - \frac{M_o}{S_1} = -\frac{377000}{512} \left(1 - \frac{13.1 \times 20}{181}\right) - \frac{189 \times 12000}{4643}$$

$$= -159 \text{ psi} < +164 \text{ psi} \text{ OK}$$

WITH $f_{pc} \leq .82 f_{py} = 189 \text{ ksi} \leftarrow$ CONTROLS

$$\leq .74 f_{pu} = 200 \text{ ksi}$$

$$A_p = \frac{P_i}{f_{pc}} = 2.0 \text{ in}^2 \quad 14 \text{ GRADE 270 } - \frac{1}{2} \text{ } \phi \text{ STRANDS}$$

B. BEAM WITH STRANDS HARPED AT $\frac{1}{3}$ POINTS :ASSUME $h = 38$ " GIVING $w_o = 481$ plf $R = .80$

$$M_o = 182 \text{ ft-k}$$

$$M_d = 227$$

$$M_e = 454$$

STRESS LIMITS SAME AS BEFORE, EXCEPT

$$f_{ti} = 3\sqrt{f'_{ci}} = 164 \text{ psi} \quad \text{CONTROLS}$$

19.3 (CON'T) RESULTS IN: $h = 38''$

$$A_p = 2.00 \text{ in}^2$$

14 GRADE 270 - $\frac{1}{2}'' \phi$
STRANDS (AS
BEFORE)

$$e = 15''$$

19.4

MATERIAL PROPERTIES

$f'_c = 5000 \text{ psi}$ $f'_{ci} = 3500 \text{ psi}$

$f_{pu} = 270 \text{ ksi}$ $f_{py} = 243 \text{ ksi}$

$n = 8$ $R = 0.82$ $A_{ps} = 0.612 \text{ in}^2$
 LOW RELAXATION STRAND $\gamma_p = 0.28$

LOADS

$w_D = 53.5 \text{ psf}$

$w_L = 225 \text{ psf}$

$w_D = 53.5(3) = 160.5 \text{ plf}$

$w_L = 225(3) = 675 \text{ plf}$

$M_D = \frac{w_D L^2}{8} = \frac{160.5(20)^2}{8} = 8025 \text{ ft}\cdot\text{lb}$

$M_L = \frac{675(20)^2}{8} = 33,750 \text{ ft}\cdot\text{lb}$

PRESTRESSING FORCES

AT TRANSFER

$f_p \leq \begin{cases} 0.74 f_{pu} = 200 \text{ ksi} \\ 0.82 f_{py} = 199 \text{ ksi} \end{cases} \leftarrow \text{USE}$

$P_i = 0.612(199) = 122 \text{ kips}$

$P_e = R P_i = 0.82(122) = 100 \text{ kips}$

SECTION PROPERTIES

$b_f = 36 \text{ in}$ $h = 8 \text{ in}$ $d = 7 \text{ in}$

$b_w = 10.5 \text{ in}$

$A = 154 \text{ in}^2$ $I = 1224 \text{ in}^4$ $y_b = 3.89 \text{ in}$

$S_b = 314.8 \text{ in}^3$

$S_t = 297.9 \text{ in}^3$

$e = 2.89 \text{ in}$ $c_1 = 4.11 \text{ in}$ $c_2 = 3.89 \text{ in}$

$L = 20 \text{ ft}$

CLASS U BEAM

$f_{ti} = 3 \sqrt{f'_{ci}} = 177 \text{ psi}$

$f_{ci} = 0.6 f'_{ci} = -2100 \text{ psi}$

$f_{ts} = 7.5 \sqrt{f'_c} = 530 \text{ psi}$

$f_{cs} = 0.45 f'_c = -2250 \text{ psi}$

		TOP	BOTTOM
INITIAL STRESS AT END*	P_i/A	122/154	-792
	$P_i e/s$	122(2.89)/s	1184
			-1120
			392
INITIAL STRESS AT MIDSPAN	M_D/s	8,025(12)/s	-323
			306
			-69
			-1606
FINAL STRESS AT END*	P_e/A	100/154	-649
	$P_e e/s$	100(2.89)/s	970
			-918
			321
LONG TERM STRESS AT MIDSPAN	M_D/s	8,025(12)/s	-323
			306
			-2
			-1261
MAY SERVICE STRESS	M_L/s	33,750(12)/s	-1360
			1287
		-1362	26

* ASSUMES CONSTANT ECCENTRICITY STRAND.
 MEETS ALL CLASS U REQUIREMENTS EXCEPT f_{ci} : ADD REINFORCEMENT TO TAKE TENSILE FORCE.

(CON'T.)

19.4 (CONT.)

DESIGN TENSILE REINFORCEMENT, $f_s = 36 \text{ ksi}$

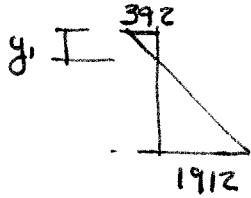

$$y_1 = h \frac{392}{392+1912} = 8 \left(\frac{392}{392+1912} \right) = 1.36 \text{ in}$$

$$T_s = f_{ci} b \cdot y_1 / 2 = 392 (36) 1.36 / 2 = 9604 \text{ lb}$$

$$f_s = \frac{T_s}{f_s} = \frac{9604}{36000} = 0.267 \text{ in}^2 \text{ USE } \geq \text{No. 4 (13) BARS}$$

(IN PRACTICE THESE BARS ARE NOT USED)

CHECK FLEXURAL STRENGTH

$$M_u = 1.2 (8025) + 1.6 (33750) = 63630 \text{ Ft-lb}$$

$$f_{ps} = f_{pu} \left[1 - \frac{\gamma_p f_{pu}}{\beta_1 f_c'} \right] = 270 \left[1 - \frac{.28 (270) \cdot .612}{0.80 (5) 36 (7)} \right] = 257.6 \text{ ksi}$$

$$a = \frac{A_{ps} f_{ps}}{.85 f_c' b} = \frac{0.612 (257.6)}{.85 (5) 36} = 1.03 < 1.25 \quad b = 36 \text{ OK for } \rho$$

$$M_n = A_{ps} f_{ps} (d - a/2) = 0.612 (257.6) \left(7 - \frac{1.03}{2} \right) \frac{1000}{12} = 85,194 \text{ Ft-lb}$$

$$c/d_t = \frac{a/\beta_1}{d_t} = \frac{1.03/0.80}{7} = 0.184 < 0.375 \quad \therefore \phi = 0.90$$

$$\phi M_n = 0.9 (85,200) = 76,700 > M_u \quad \underline{\text{OK}}$$

$$19.5 \quad P_i = 122 \text{ kips}, \quad f_{pi} = 199 \text{ ksi}, \quad n = 8$$

ELASTIC SHORTENING

$$\Delta f_s = n f_c$$

$$f_c = -\frac{P_i}{A} - \frac{P_i \cdot e}{I} + \frac{M_o e}{I} = -\frac{122000}{154} - \frac{122000(2.89)^2}{1224.5} + \frac{8025 \times 12 \times 2.89}{1224.5}$$

$$= -1397 \text{ psi}$$

$$\Delta f_s = \frac{8(1397)}{1000} = 11.2 \text{ ksi}$$

JACKING STRESS TO COMPENSATE

$$f_j = 199 + 11.2 = 210 \text{ ksi} < \begin{cases} .94 f_{py} = 228 \text{ ksi} \\ .80 f_{pu} = 216 \text{ ksi} \end{cases}$$

$$\therefore P_j = A_p f_j = 210(612) = 129 \text{ kips}$$

CREEP

$$\Delta f_{s, \text{creep}} = C_c n f_c$$

$$C_c = 2.7 \text{ TABLE 2.1}$$

$$\Delta f_s = 2.7(11.2) = 30.2 \text{ ksi}$$

SHRINKAGE

$$\epsilon_s = 0.0006$$

$$\Delta f_s = \epsilon_s E_s = 0.0006(27,500) = 16.5 \text{ ksi}$$

RELAXATION

$$\frac{f_p}{f_{pi}} = 1 - \frac{\log t}{10} \left(\frac{f_{pi}}{f_{py}} - 0.55 \right)$$

$$\text{ASSUME } f_{pi} = 0.9(199) = 179 \text{ ksi}$$

$$t = 5 \text{ years} = 43,800 \text{ hours}$$

$$f_p = 179 \left[1 - \frac{\log 43,800}{10} \left(\frac{179}{243} - 0.55 \right) \right] = 179(913) = 163.5$$

$$\Delta f_s = 179 - 163.5 = 15.5 \text{ ksi}$$

$$R = \frac{199 - 30.2 - 16.5 - 15.5}{199} = 0.69$$

$R < R_{\text{ASSUMED}} = 0.82$ & ASSUMES ELASTIC SHORTENING IS COMPENSATED DURING JACKING

$$19.6 \quad b_w = 5 \text{ in} \quad h = 30 \text{ in} \quad d = 24 \text{ in}$$

$$f'_c = 5000 \text{ psi} \quad f_y = 60,000 \text{ psi}$$

$$\text{No. 4 (13) STIRRUPS} \quad A_v = 0.40 \text{ in}^2$$

$$V_u = 35.55 \text{ k}$$

$$M_u = 474 \text{ ft-k}$$

$$V_c = \left(0.6 \sqrt{f'_c} + 700 \frac{V_u d}{M_u} \right) b_w d$$

$$= \left(0.6 \sqrt{5000} + 700 \frac{35.55 \times 24}{474 \times 12} \right) 5 \times 24 = 17.69 \text{ k}$$

CHECKS

$$\frac{V_u d}{M_u} = \frac{35.55 \times 24}{474 \times 12} = 0.15 < 1.0 \quad \underline{\text{OK}}$$

$$2 \sqrt{f'_c} b_w d = 16.97 \text{ k} < V_c < 5 \sqrt{f'_c} b_w d = 42.43 \text{ k} \quad \underline{\text{OK}}$$

$$s = \frac{\phi A_v f_y d}{V_u - \phi V_c} = \frac{0.75 (.40) 60 (24)}{35.55 - 0.75 (17.69)} = 19.3$$

USE $s = 18 \text{ in}$

CHECK

$$s \leq 24 \text{ in} \quad \underline{\text{OK}}$$

$$s \leq \frac{3}{4} h = 22.5 \text{ in} \quad \underline{\text{OK}}$$

$$s \leq \frac{A_v f_y}{50 b_w} = \frac{0.4 (60000)}{50 (5)} = 96 \text{ in} \quad \underline{\text{OK}}$$

19.8

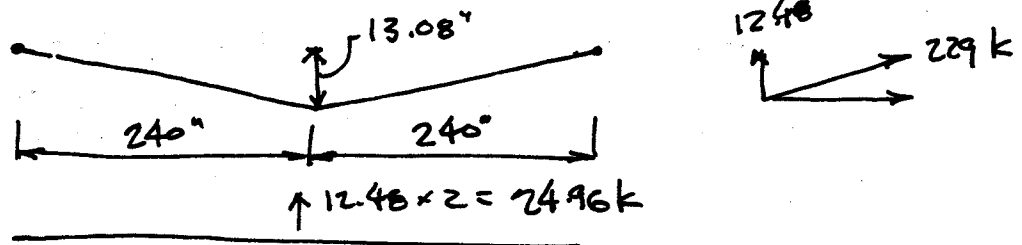

$$\Delta_{pi} = \frac{Pl^3}{48EI} = \frac{24960 \times 480^3}{48 \times 3500000 \times 24600} = -.67''$$

$$\Delta_o = \frac{5w_0l^4}{384EI} = \frac{5 \times 469 \times 480^4}{384 \times 12 \times 3500000 \times 24600} = +.32''$$

(a) $\Delta_{pi} + \Delta_o = -.67 + .32 = -.35''$ UPWARD

(b) AFTER 1 YEAR:

$$\Delta_{pe} = \Delta_{pi} \times \frac{P_e}{P_i} = -.54''$$

$$\Delta_e = \frac{Pl^3}{48EI} = \frac{21500 \times 480^3}{48 \times 3500000 \times 24600} = +.58''$$

$$C_t = \frac{t^{0.66}}{10 + t^{0.66}} = C_u = 1.934$$

$$\begin{aligned} \Delta_{360} &= -\Delta_{pe} - \frac{(\Delta_{pi} + \Delta_{pe})C_t}{2} + \Delta_o(1 + C_t) + \Delta_e \\ &= -.54 - \frac{(-.67 + .54)1.934}{2} + .32(2.934) + .58 \\ &= -.19'' \text{ UPWARD} \end{aligned}$$

20.1

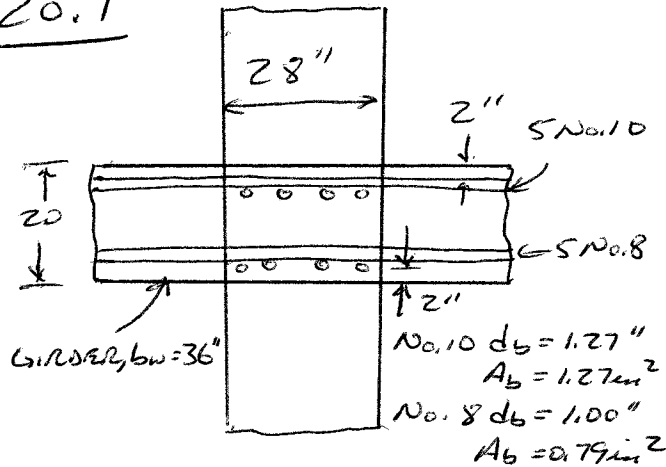

SATISFACTORY TO CHECK BENDING IN PLAN OF THE GIRDER SINCE THIS WILL CONTROL

$$b_{eff}(\text{GIRDER}) = 36 + 16 \times 5 = 116''$$

$$M_{nb}^- \quad 5 \text{ No. 10}, A_s = 6.35 \text{ in}^2$$

$$A_s f_y = 6.35 \times 60 = 381 \text{ KIPS}$$

$$d = 20 - 2 - 1.27/2 = 17.36''$$

$$a = 381 / (0.85 \times 4 \times 36) = 3.11''$$

$$M_g^- = A_s f_y (d - \frac{a}{2}) = \frac{381 (17.36 - \frac{3.11}{2})}{12} = 5021 \text{ KIPS}$$

$$M_{nb}^+ \quad 5 \text{ No. 8}, A_s = 3.95 \text{ in}^2$$

$$A_s f_y = 237 \text{ KIPS}$$

$$d = 20 - 2 - 1 - \frac{1.0}{2} = 16.5''$$

$$a = 237 / (0.85 \times 4 \times 116) = 0.60$$

$$M_g^+ = \frac{237 (16.5 - \frac{0.60}{2})}{12} = 3201 \text{ KIPS}$$

COLUMNS

UPPER COL:

$$K_n = \frac{P_u}{f_c A_g} = \frac{1098}{4 \times 784} = 0.350$$

LOWER COL:

$$K_n = \frac{1160}{4 \times 484} = 0.370$$

REINF = 12 No. 9 BARS, $A_{st} = 12.0 \text{ in}^2$

$$\rho_g = 0.0153 -$$

$$\text{COVER TO CENTER OF BAR} = 2 + 1.128/2 = 2.56''$$

$$y = (28 - 2 \times 2.56) / 28 = 0.82$$

USE GRAPH A.7, $\gamma = 0.80$

$$\text{UPPER COL: } R_m = \frac{M_{nc}}{f_c A_g h} = 0.163$$

$$M_{nc} = 0.163 \times 4 \times 784 \times 28 / 12 = 12071 \text{ KIPS}$$

$$\text{LOWER COL: } R_m = 0.166$$

$$M_{nc} = \frac{0.166}{0.163} \times 1207 = 12151 \text{ KIPS}$$

$$\text{BY INSPECTION, } \sum M_{nc} \geq \frac{6}{5} M_{nb} \quad \checkmark \text{ OK}$$

MINIMUM TRANSVERSE REINF. IN COLUMN ADJACENT TO JOINT -

$$l_o = \text{MAX}(h = 28'', 1/6 \text{ CLEAR SPAN} = (13 \times 12 - 20) / 6 = 22.7'', 18'') = 28''$$

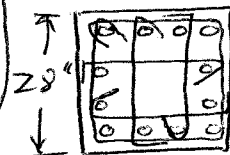

MAX SPACING OF CROSS-TIES = 14" REQUIRES TWO CROSS-TIES EACH DIRECTION

MAX SPACING OF TRANSVERSE REINF. ALONG COLUMN =

$$S = \text{MIN}(\frac{l_o}{4} = 7'', 6d_b = 6.8'', S_x)$$

$$S_x = 4 + \frac{14 - 4x}{3} = 4 + \frac{14 - 8.76}{3} = 5.74''$$

USE $S = 5''$

$$\text{FOR NO. 4 BARS, } h_c = 28 - 2 \times 1.5 - 0.5 = 24.5''$$

$$A_{ch} = 25 \times 25 = 625 \text{ in}^2$$

A_{sh} = LARGER OF

$$0.3 \frac{s_b c f_c'}{f_y t} \left(\frac{A_g}{A_{ch}} - 1 \right) =$$

$$0.3 \frac{5 \times 25 \times 4}{60} \left(\frac{784}{625} - 1 \right) = 0.636$$

AND

$$0.09 \frac{s_b c f_c'}{f_y t} = 0.09 \frac{5 \times 25 \times 4}{60}$$

$$= 0.75 \text{ in}^2$$

$$4 \text{ NO. 4 LEGS} \rightarrow A_{sh} = 0.80 \text{ in}^2 \quad \checkmark$$

OK

20.2 1ST LAYOUT JOINT
SO THAT BARS FIT -

COL. DIMENSION MUST BE $\geq 20d_b$ BASED ON d_b FOR FLEXURAL MEMBERS -

$$20 \times 1.27 = 25.4" < 28" \text{ OKAY}$$

SHEAR IN JOINT:

GIRDER DIRECTION CONTROLS

NEG. BENDING

$$T_1 = 1.25 A_s f_y = 1.25 \times 6.35 \times 60 = 476 \text{ K}$$

$$d = 17.36"$$

$$a = 476 / (0.85 \times 4 \times 36) = 3.89"$$

$$M^- = \frac{476}{12} \left(17.36 - \frac{3.89}{2} \right) = 611 \text{ K}$$

POS. BENDING

$$T_2 = 1.25 \times 3.95 \times 60 = 296 \text{ K}$$

$$d = 16.5", a = \frac{296}{0.85 \times 4 \times 116} = 0.75"$$

$$M^+ = \frac{296}{12} \left(16.5 - \frac{0.75}{2} \right) = 398 \text{ K}$$

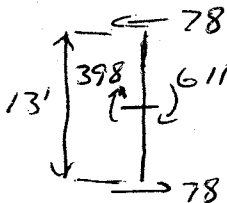

$$V_{col} = \frac{611 + 398}{13} = 78 \text{ K}$$

$$V_u = T_1 + T_2 - V_{col} = 476 + 296 - 78 = 694 \text{ K}$$

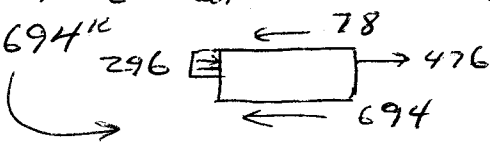

JOINT CONFINED ON 4 SIDES

$$A_j = 784 \text{ in}^2$$

$$\phi V_n = \frac{0.85 \times 20 \sqrt{4000} \times 784}{1000} = 843 \text{ K} > V_u \text{ OKAY}$$

SINCE JOINT IS CONFINED ON ALL 4 SIDES, REINFORCEMENT CAN BE REDUCED TO 1/2 OF THAT REQUIRED WITHIN l_o ,

SPACING $\leq 6"$ PER ACI CODE 21.7.3.2. USE HOOP AND CROSSTIES AS SHOWN FOR PROBLEM 20.1 AT A 6" SPACING WITHIN THE JOINT -

TRANSVERSE COL. SHEAR REINF.

FROM SOLUTION TO PROB 20.1, NO. 4 HOOPS W/ 2 CROSSTIES IN EACH DIRECTION ARE REQ. FOR $l_o = 28"$

FROM EACH FACE OF THE JOINT.

PER ACI CODE 21.6.5.1, COLUMN SHEARS NEED NOT EXCEED THOSE DETERMINED FROM JOINT SHEARS BASED ON PROBABLE MOMENT STRENGTH MPR FROM TRANSVERSE MEMBERS, BUT NOT LESS THAN FACTORED SHEAR BASED ON ANALYSIS -

BASED ON PROB 20.1, MPR FROM BEAMS ARE BELOW THOSE FROM COLS AND WILL BE USED TO CHECK COL. SHEAR. IF THIS WERE NOT SO, THE LOWER VALUES OF P_u IN COLS WOULD BE USED TO CALCULATE MPR FOR COLS BECAUSE A HIGHER MOMENT CAPACITY WOULD BE OBTAINED.

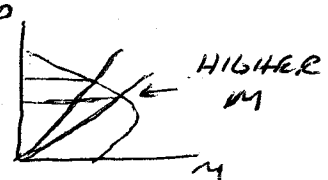

$$MPR_{COL} = \frac{1}{2} (611 + 398) = 505 \text{ K}$$

$$A = \frac{(13 \times 12 - 20)}{12} = 11.33'$$

$$V_e = \frac{2 \times 505}{11.33} = 89 \text{ K} > 31 \text{ OR } 29 \text{ K}$$

$$P_{u_{min}} = 1098 - 21 = 1077 \text{ K}$$

$$A_s f_c / 20 = 784 \times 4 / 20 = 157 \text{ K}$$

$\rightarrow V_c$ MAY BE USED IN DESIGN

CONSERVATIVELY,

$$\phi V_c = \frac{0.75 \times 20 \sqrt{4000} \times 784}{1000} = 67.5 \text{ K}$$

PLACING NO. 4 HOOPS + CROSSTIES

AT SMALLER OF $6d_b = 6.8"$

OR $6"$, GIVES

$$\phi V_s = \frac{0.75 \times 0.78 \times 60 \times 25.4}{6} = 168 \text{ KIPS}$$

$$V_e < \phi (V_c + V_s) \text{ OK}$$

20.3 MPR BASED ON 1.25fy

CLEAR SPAN = 28 - 3 = 25'

NEGATIVE BENDING S No. 10 $A_s = 6.35 \text{ in}^2$

$$a = 1.25 \times 6.35 \times 60 / (0.85 \times 4 \times 27) = 5.19''$$

$$M_{pr1} = \frac{1.25 \times 6.35 \times 60}{12} \left(33.4 - \frac{5.19}{2} \right) = 1223 \text{ K}$$

POSITIVE BENDING S No. 9 $A_s = 5.80 \text{ in}^2$

$$a = 1.25 \times 5.80 \times 60 / (0.85 \times 4 \times 27) = 2.04''$$

$$M_{pr2} = \frac{1.25 \times 5.80 \times 60}{12} \left(33.4 - \frac{2.04}{2} \right) = 1012 \text{ K}$$

EFFECT OF GRAVITY LOADS $w_u \cdot l_n / 2 = (1.2 \times 2 + 1.0 \times 0.93) 25 / 2 = 42 \text{ K}$

$$V_e = \frac{1223 + 1012}{25} + 4 = 89 + 42 = 131 \text{ K}$$

SINCE $89 > \frac{1}{2} \times 131$, STIRRUPS MUST RESIST V_e OVER $2h = 2 \times 36 = 72''$ FROM THE FACE OF BOTH COLUMNS.

FIRST HOOP IS PLACED 2'' FROM COL. FACE.

MAXIMUM SPACING $S = \min \left\{ \frac{d}{4} = 33.4 / 4 = 8.35'' \right\}$, 8db FOR SMALLEST LONGITUDINAL BAR = $8 \times 1.128 = 9.02''$, OR 24db FOR HOOP BARS (No. 3) = $24 \times 3/8 = 9''$ = 8''

$$A_v = \frac{V_s s}{f_y h d} = \frac{(V_e / \phi) s}{f_y h d} = \frac{(130 / 0.75) 8}{60 \times 33.4} = 0.69 \text{ in}^2$$

USE No. 4 bars FOR DOUBLE HOOPS AS SHOWN

$$A_v = 0.80 \text{ in}^2$$

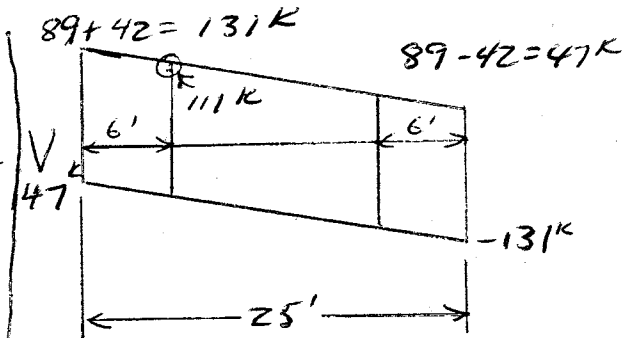
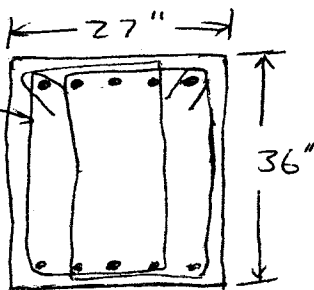

72'' (= 6') FROM FACE OF COLUMN: $V_e = 111 \text{ K}$

$$V_c = 2 \sqrt{4000} \times 27 \times 33.4 / 1000 = 114 \text{ K}$$

SPACING CAN INCREASE TO $d/2 = 16.7'' < 24''$ USE 16''

$$A_v = \frac{\left(\frac{111}{0.75} - 114 \right) 16}{60 \times 33.4} = 0.27 \text{ in}^2$$

$$A_{vmin} = \frac{50 L_w S}{f_y} = \frac{50 \times 27 \times 16}{60,000} = 0.36 \text{ in}^2$$

USE SINGLE No. 4 STIRRUPS ($A_v = 0.40 \text{ in}^2$) AT 16''

STIRRUPS MUST HAVE SEISMIC HOOKS AT BOTH ENDS -

USE 1 @ 2'' FROM FACE OF

SPT,
9 @ 8'',

+ 15 @ 16'' TO MIDSPAN -

20.5
(a)

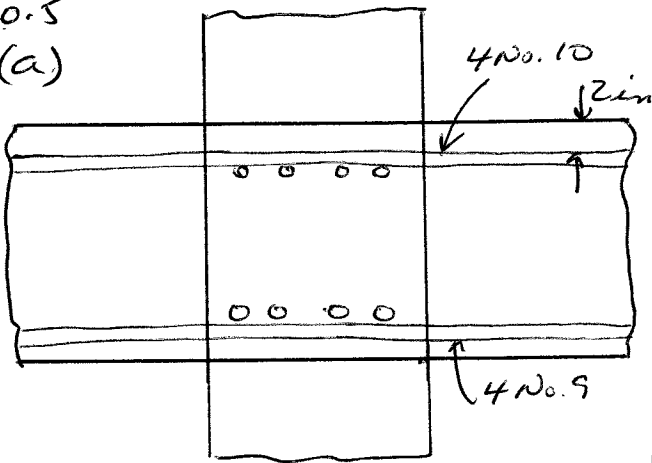

Satisfactory to check
bending in plane of girder
since this will control -
beff (girder) = 20 + 2 x 32 = 84 in.

M_{mb}^- : 4 No. 10, $A_s = 5.08 \text{ in}^2$

$A_s f_y = 5.08 \times 60 = 304.8 \text{ KIPS}$

$d = 28 - 2 - 1.27/2 = 25.37 \text{ in.}$

$a = 304.8 / (0.85 \times 4 \times 20) = 4.48 \text{ in.}$

$M_{mb}^- = A_s f_y (d - \frac{a}{2}) = \frac{304.8}{12} (25.37 - \frac{4.48}{2})$

$= 587.5 \text{ ft-kips}$

M_{mb}^+ : 4 No. 9, $A_s = 4 \text{ in}^2$

$A_s f_y = 240 \text{ kips}$

$d = 28 - 2 - 1.128/2 = 25.44 \text{ in.}$

$a = 240 / (0.85 \times 4 \times 84) = 0.84 \text{ in.}$

$M_{mb}^+ = \frac{240}{12} (25.44 - \frac{0.84}{2}) = 500 \text{ ft-kips}$

Columns:

Upper Col - $K_n = \frac{P_u}{f_c A_g} = \frac{1100}{4 \times 676} = 0.406$

Lower Col - $K_n = \frac{1230}{4 \times 676} = 0.455$

Reinf = 8 No. 14 bars, $A_{st} = 18 \text{ in}^2$

$e_g = 0.0266$

Cover to center of
bar = $2 + 1.693/2 = 2.85 \text{ in.}$

$y = \frac{26 - 2 \times 2.85}{26} = 0.78$

Use Graphs A.6 + A.7

($y = 0.70 + 0.80$)

Upper col A.7 A.6

$R_n = \frac{M_{nc}}{f_c A_g h} = 0.8(0.212) + 0.2(0.95)$

$= 0.209$
 $M_{nc} = 0.209 \times 4 \times 676 \times 26/12 = 1224 \text{ ft-kips}$

Lower col A.7 A.6

$R_n = 0.8(0.207) + 0.2(0.187)$
 $= 0.203$

$M_{nc} = 0.203 \times 4 \times 676 \times 26/12 = 1189 \text{ ft-kips}$

By inspection $\sum M_{nc} > \frac{6}{5} \sum M_{mb}$

Minimum transverse reinf.
in col. adjacent to joint -

$l_o = \max [h = 26 \text{ in, } \frac{1}{6} \text{ clear span} = (12 \times 12 - 28)/6 = 19.3 \text{ in, } 18 \text{ in.}]$
 $= 26 \text{ in}$

No. 4 hoops

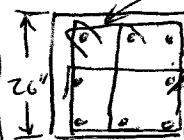

Max spacing of
cross-ties = 14 in
One cross-tie
each way -

$h_{x \max} = 13 - 2.85 + 1.693 \times 1.05$
 $= 12.34 \text{ in}$

Max spacing of transverse
reinf. in columns =

$S = \min (\frac{4}{3} = 6.5, 6d_b = 10.2, S_o)$

$S_o = 4 - \frac{14 - h_x}{3} = 4 - \frac{14 - 12.34}{3} = 4.55 \text{ in}$

Use $S = 4 \text{ in.}$

For No. 4 bars,

$h_c = 26 - 2 \times 1.5 = 23 \text{ in.}$

$A_{ch} = 23^2 = 529 \text{ in}^2$

20.5 Continued

$$A_{sh} \geq 0.3 \frac{5bcf_c}{f_{yt}} \left(\frac{A_g}{A_{ch}} - 1 \right)$$

$$= 0.3 \frac{4 \times 23 \times 4}{60} \left(\frac{676}{529} - 1 \right) = 0.51 \text{ in.}^2$$

$$\geq 0.09 \frac{5bcf_c}{f_{yt}} = 0.09 \frac{4 \times 23 \times 4}{60} = 0.54 \text{ in.}^2$$

3 No. 4 legs = 0.6 in² OK

(b) Mpr based on 1.25 fy

Clear span = 24 - 26/12 = 21.83 ft

Negative bending - Ac = 5.08 in²

$$a = 1.25 \times 5.08 \times 60 / (0.85 \times 4 \times 84) = 5.6 \text{ in.}$$

d = 25.37 (part a)

$$M_{pr1} = \frac{1.25 \times 5.08 \times 60 \left(25.37 - \frac{5.6}{2} \right)}{12}$$

$$= 717 \text{ ft-kips}$$

Positive bending - As = 4.00 in²

$$a = 1.25 \times 4 \times 60 / (0.85 \times 4 \times 84) = 1.05 \text{ in.}$$

$$M_{pr2} = \frac{1.25 \times 4 \times 60 \left(25.44 - \frac{1.05}{2} \right)}{12} = 623 \text{ ft-kips}$$

$$\frac{W_{pln}}{Z} = \frac{(1.2 \times 2.8 + 1.0 \times 1.3) \times 21.83 / 2}{2} = 50.9$$

$$V_e = \left(\frac{717 + 623}{21.83} \right) + 50.9 = 112 \text{ KIPS}$$

Since 61.4 > 1/2 112, stirrup must resist Ve over 2h = 2 x 28 = 56 in.

from the face of both columns

First hoop is placed 2 in. from cal. face

Max spacing S = min [d/4 = 25.4/4 = 6.35 in.]

8db for smallest longitudinal bar

$$= 8 \times 1.128 = 9.02 \text{ in.}, 24db \text{ for hoop bars}$$

$$(\text{No. 3}) = 24 \times 3/8 = 9"] = 6 \text{ in.}$$

$$A_v = \frac{V_s S}{f_{yt} d} = \frac{(V_e / \phi) S}{f_{yt} d} = \frac{(112 / 0.75) \times 6}{60 \times 25.4}$$

$$= 0.59 \text{ in.}^2$$

Use No. 4 bars for double hoops

$$A_v = 0.80 \text{ in.}^2$$

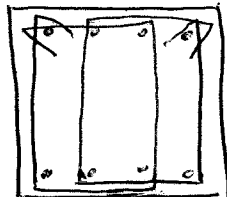

$$61 + 51 = 112 \text{ KIPS}$$

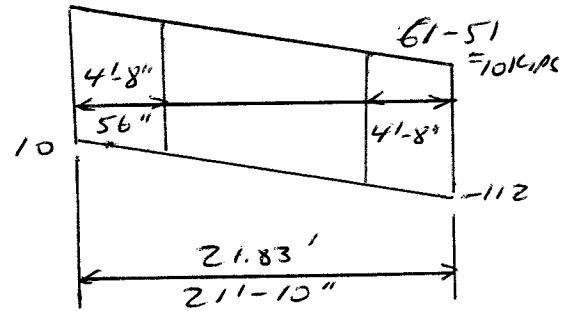

56 in (41.8") from cal. face,

$$V_e = 112 - 4 \times 3 \times 4.36 \text{ kips/ft} = 92 \text{ kips}$$

$$V_c = \frac{2 \sqrt{4000} \times 20 \times 25.4}{1000} = 64 \text{ KIPS}$$

spacing can increase

$$\text{to } \frac{d}{2} = 12.7" < 24", \text{ use } 12 \text{ in.}$$

$$A_v = \frac{\left(\frac{92}{0.75} - 64 \right) \times 12}{60 \times 25.4} = 0.46 \text{ in.}^2$$

$$A_{vmin} = \frac{50 S_w S}{f_{yt}} = \frac{50 \times 20 \times 12}{60 \times 1000} = 0.20$$

Drop spacings to 10 in.,

Av becomes 0.38 in² + use

a single No. 4 stirrup

$$A_v = 0.40 \text{ in.}^2$$

stirrups must have seismic hooks @ both ends

Use 1 double hoop 2 in. from face of support,

9 double hoops @ 6 in

7 single stirrups @ 10 in.

leaves 5 in. space from

span @ + 10 in. space

from hoop on other side

of @