



The Public Authority for Applied Education and Training

College of Technological Studies

Department of Civil Engineering Technology



CE 261 Structural Analysis

(Class Notes)

Compiled By:

Dr. Mohammad S. Alshaiji

Disclaimer:

This work is by no means the original work of Dr. Alshaiji. The material included in this class notes is merely a collection of examples and text copied directly from the original work by other authors. This package was compiled to serve as a supplement to the textbook required by the course syllabus.



Table of Contents

Chapter (1): Introduction to Structural Engineering Concepts.....	1
1.1 Engineering Design Process.....	1
1.2 Structural Analysis.....	2
1.3 Structural Form.....	2
1.4 Structural Elements:.....	2
1.4.1 Tie Rods:.....	2
1.4.2 Beams:.....	2
1.4.3 Columns:.....	3
1.5 Types of Structures:.....	3
1.5.1 Trusses:.....	4
1.5.2 Cables and arches:.....	4
1.5.3 Frames:.....	4
1.5.4 Surface Structures:.....	5
1.6 Codes and Loads types and categories:.....	5
1.6.1 Codes:.....	5
1.6.2 Load Types:.....	6
1.6.3 Load Categories:.....	8
Chapter (2): Beam Analysis.....	17
2.1 Loading on Beams:.....	17
2.2 Loading Types:.....	17
2.3 Support Types:.....	18
2.4 Beam Types:.....	20
2.5 Beam Reactions:.....	21
2.6 Sign Convention:.....	21
2.7 Examples:.....	22
2.8 Internal Forces in Beams:.....	24
2.8.1 Procedure for Analysis.....	25
2.8.2 Examples:.....	26
2.9 Shear Force and Bending Moment Diagrams:.....	29
2.9.1 Procedure for Analysis.....	29
2.9.2 Examples:.....	32
2.10 Problems:.....	39
Chapter (3): Truss Analysis.....	41

3.1 Introduction:.....	41
3.2 Assumptions for Analysis of Trusses:.....	42
3.3 Method of Joints:	42
3.3.1 Procedure for Analysis	42
3.3.2 Examples:.....	44
3.4 Problems:.....	48
3.5 Method of Sections:	51
3.5.1 Procedure for Analysis:	51
3.5.2 Examples:.....	52
3.6 Problems:.....	56
Chapter (4): Frame Analysis	58
4.1 Types of Frame Structures:.....	58
4.1.1 Rigid Structural Frame.....	58
4.1.2 Braced Structural Frames.....	59
4.1.3 Load path in Frame Structure:.....	61
4.1.4 Comparison of Frame structures with Normal Load bearing Traditional High Rise Building:	61
4.1.5 Frame Reactions:	62
4.1.6 Examples:.....	62
4.2 Internal Forces in Frames:	66
4.2.1 Examples:.....	66
4.3 Shear Force and Bending Moment Diagrams:.....	69
4.3.1 Procedure for Analysis:	69
4.3.2 Examples:.....	72
4.4 Problems:.....	76
Chapter (5): Beam Deflection	78
5.1 Introduction:.....	78
5.2 Factors Affecting Beam Deflections	78
5.3 Calculating Beam Deflections:.....	78
5.4 Examples:	78
5.5 Problems:.....	82
Chapter (6): Loads on Structures	83
6.1 Live Load Reduction:	83
6.1.1 Floors:	83
6.1.2 Roofs:	86

6.2 Tributary Areas for beams and columns:.....	86
6.2.1 Approximate Methods:.....	88
6.3 Concepts in Structural Design:.....	90
6.3.1 LRFD:	90
6.3.2 Load Combinations:	91
6.3.3 LRFD Load Combinations:.....	92
6.3.4 Examples:	93
6.4 Problems:.....	104
Chapter (7): Useful Formulas	105
7.1 Beam Design Formulas with Shear and Moment Diagrams	105
7.2 Bending Moment Diagrams and Equations for Frames	121
7.3 Geometric Properties of Line and Area Elements:.....	124
7.4 Center of Gravity and Mass Moment of Inertia of Homogenous Solids:.....	127
7.5 Fundamental Equations of Statics:	128
7.6 SI Prefixes:	129
7.7 Conversion Factors (FPS) to (SI)	129
7.8 Conversion Factors (FPS):.....	129
7.9 Conversion Factors Table:	130
7.10 Cheat Sheet:	131
Glossary	135



Chapter (1): Introduction to Structural Engineering Concepts

1.1 Engineering Design Process

Conceptual Stage:

- Needs are identified then objectives are expressed to meet these needs
- Input from:
 - Clients
 - Governmental regulatory agencies
 - Architects, planners, and engineers

Preliminary Design Stage:

- Creative ideas by the engineers
- Keep in mind construction aspects
- Thorough consideration of expected loads on the structure at all construction stages and during occupancy of the finished structures.
- Sizing of structural elements for safety and serviceability
- Architectural Constraints
 - Simplicity & Duplication
 - Fabrication & Construction Procedures
- Preliminary design approximate theories of structural analysis are used to minimize time during this phase

Selection Stage:

- At this stage, all alternatives are presented and all parties involved participate in the selection stage so the final design stage can begin

Final Design Stage:

- Loads are determined in greater accuracy than the preliminary stage.
- All loading combinations are examined in this stage.
- Structural analysis is carried with greater accuracy than the preliminary stage with the elimination of all approximations
- The results are presented in sets of drawings and specifications showing
 - Sizing of Members
 - Detailing
 - Quality of workmanship
 - Design/building codes used.
 - Bill of Materials
 - Total Cost

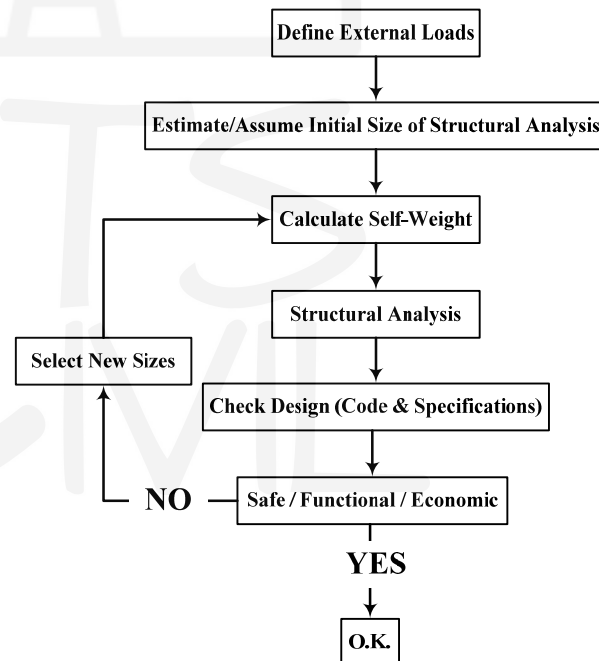

Figure 1-1: Summary of structural engineering design process

1.2 Structural Analysis

- Structural Analysis: the determination of the structural response to specific loads and actions.
- Response: measured by establishing the forces and deformations throughout the structure
- Analysis: based on engineering mechanics theory, laboratory research, experience, and engineering judgement

1.3 Structural Form

The form of the structure depends on many considerations as:

- Functional requirements
- Aesthetic (Beauty) requirement
- Surface and subsurface conditions
- Material availability
- Construction Expertise
- Economical limitations
- Environmental impact
- Safety

1.4 Structural Elements:

1.4.1 Tie Rods:

- Subjected to tensile force only.
- They are slender.
- They are referred to as “tie rods” and “bracing ties”
- They are made from bars, angles, and channels.
- Strength is limited only by material strength



Figure 1-2: Tie Rods

1.4.2 Beams:

- Usually straight, horizontal members used to resist bending moments and shear forces.
- Classified to the way they are supported.
- Resist shear force and bending moment.



Figure 1-3: Steel and concrete beams

1.4.3 Columns:

- Vertical elements resisting axial compressive loads.
- When subjected to both bending moments and axial load, they are referred to as “beam column”
- Susceptible to buckling which limits the strength of the member



Figure 1-4: Steel and concrete columns

1.5 Types of Structures:

Combination of structural elements is referred to as a “structural system”. Some Examples are:

1.5.1 Trusses:

- Used for large spanned structures.
- Consist of slender elements arranged in a triangular fashion.
- Two major types: Planer and Space.
- Convert outside loads to compression and tension forces in members.



Figure 1-5: Steel and timber trusses

1.5.2 Cables and arches:

- Used to span long distances.
- Cables are flexible and carry the loads in tension.
- Arch achieves its strength in compression.
- Arch must be rigid.



Figure 1-6: Cables and arches

1.5.3 Frames:

- Composed of beams and columns that are pinned or fixed.
- Extends in two or three dimensions.
- Its strength is derived from the moment interaction between beams and columns.

- Economical when using small beams and larger columns due to beam column action.



Figure 1-7: Steel and concrete frames

1.5.4 Surface Structures:

- Made from materials (flexible or rigid) having very small thickness compared to its other dimensions.
- They take several shapes like “thin plates” or “shells”.
- They support loads mainly in tension or compression with very little bending.
- Three-Dimensional



Figure 1-8: Examples of surface structures

1.6 Codes and Loads types and categories:

1.6.1 Codes:

- The design loading for structures is often specified in codes such as:
 - Minimum Design Loads for Buildings and Other Structures ASCE 7-16
 - International Building Code – 2018 (IBC-2018)



Figure 1-9: ASCE and IBC codes

- Design codes provide detailed technical standards used to establish actual structural design. Some Examples:
 - Building Code Requirements for Reinforced Concrete by American Concrete Institute (ACI)
 - Steel Construction Manual, by American Institute of Steel Construction (AISC)
 - British Standards (BS)
 - EURO Code (European Code)

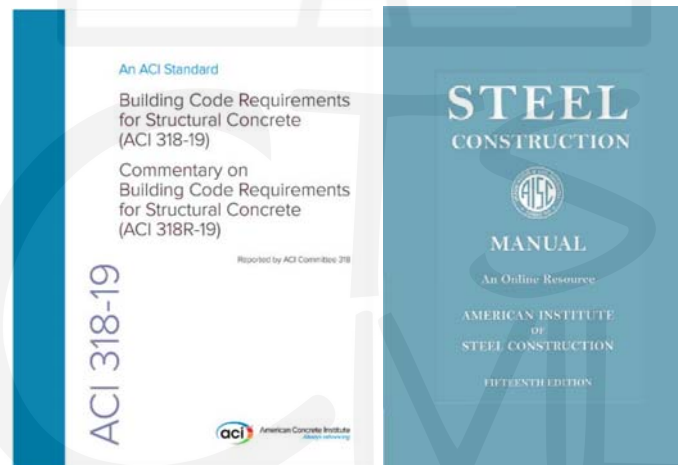

Figure 1-10: ACI and AISC codes

1.6.2 Load Types:

- **Concentrated loads:**
 - Applied over relatively small area
 - Examples: Column loads, Vehicular wheel load

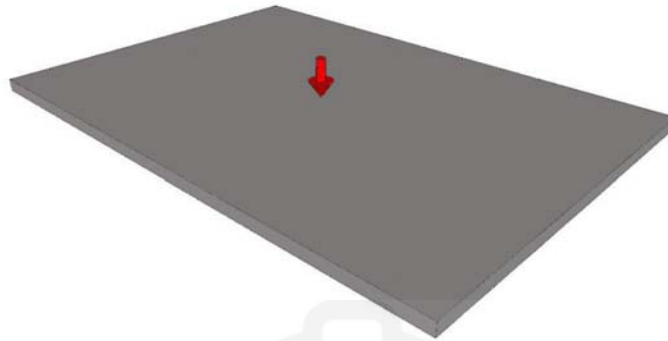

Figure 1-11: Concentrated load

- **Line loads:**

- Distributed along a narrow strip of the structure
- Examples: Beam self-weight, weight of wall or partition

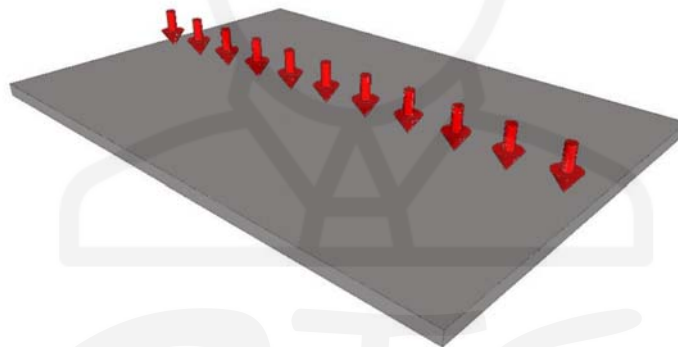

Figure 1-12: Line load

- **Surface loads:**

- Distributed over an area of the structure
- Examples: floor and roof loads

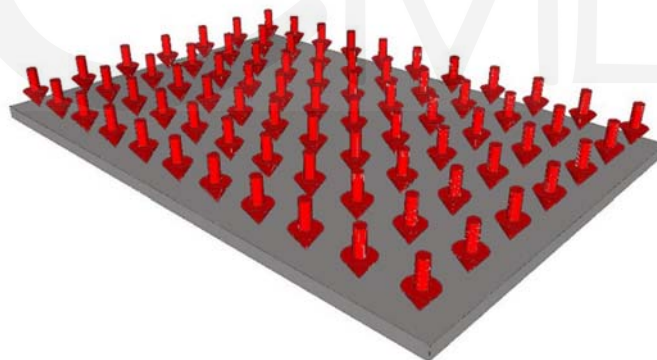

Figure 1-13: Surface load

1.6.3 Load Categories:

- **Dead Load:**

- Weight of the various structural members and the weights of any objects that are **permanently attached** to the structures.
- For a building, dead loads include weight of:

✓ Roof Slab	✓ Walls
✓ Floor Slab	✓ Windows
✓ Beams	✓ Plumbing
✓ Girders	✓ Electrical Fixtures
✓ Columns	✓ Ducts

- The dead loads can be calculated knowing the densities and dimensions of the structural components.
- The unit weights of typical building materials can be found in codes and standards.
- For loads associated with service equipment, they can be obtained from the manufactures.
- They are usually small for small structures and errors can be neglected. Yet, for multistory structures the error is high and cannot be ignored.

Table 1: Minimum Design Dead Loads

Component	Load (kN/m ²)	Component	Load (kN/m ²)
CEILING		Decking, 51 mm wood (Douglas fir)	0.24
Acoustical Fiber Board	0.05	Decking, 76 mm wood (Douglas fir)	0.35
Gypsum board (per min thickness)	0.008	Fiberboard, 13 mm	0.04
Mechanical duct allowance	0.19	Gypsum sheathing, 13 mm	0.1
Plaster on tile or concrete	0.24	Insulation, roof boards (per mm thickness)	
Plaster on wood lath	0.38	Cellular glass	0.0013
Suspended steel channel system	0.1	Fibrous glass	0.0021
Suspended metal lath and cement plaster	0.72	Fiberboard	0.0028
Suspended metal lath and gypsum plaster	0.48	Perlite	0.0015
Wood furring suspension system	0.12	Polystyrene foam	0.0004
COVERINGS, ROOF, AND WALL		Urethane foam with skin	0.0009
Asbestos-cement shingles	0.19	Plywood (per mm thickness)	0.006
Asphalt shingles	0.1	Rigid insulation, 13 mm	0.04
Cement tile	0.77	Skylight, metal frame, 10 mm wire glass	0.38
Clay tile (for mortar add 0.48 kN/m²)		Slate, 5 mm	0.34
Book tile, 51 mm	0.57	Slate, 6 mm	0.48
Book tile, 76 mm	0.96	Waterproofing membranes:	
Ludowici	0.48	Bituminous, gravel-covered	0.26
Roman	0.57	Bituminous, smooth surface	0.07
Spanish	0.91	Liquid applied	0.05
Composition:		Single-ply, sheet	0.03
Three-ply ready roofing	0.05	Wood sheathing (per mm thickness)	0.0057
Four-ply felt and gravel	0.26	Wood shingles	0.14
Five-ply felt and gravel	0.29	FLOOR FILL	
Copper or tin	0.05	Cinder concrete, per mm	0.017
Corrugated asbestos-cement roofing	0.19	Lightweight concrete, per mm	0.015
Deck, metal, 20 gage	0.12	Sand, per mm	0.015
Deck, metal, 18 gage	0.14	Stone concrete, per mm	0.023

Note: Weights of masonry include mortar but not plaster. For plaster, add 0.24 kN/m² for each face of plastered. Values given represent averages. In some cases there is a considerable range of weights for the same construction.

TABLE 4. MINIMUM DESIGN LOADS - CONTINUED

Component	Load (kN/m ²)	Component	Load (kN/m ²)
FLOORS AND FLOOR FINISHES			
Asphalt block (51 mm), 13 mm mortar	1.44	Windows, glass, frame, and sash	0.38
Cement finish (25 mm) on stone-concrete fill	1.53	Clay brick wythes:	
Ceramic or quarry tile (19 mm) on 13 mm. mortar bed	0.77	102 mm	1.87
Ceramic or quarry tile (19 mm) on 25 mm mortar bed	1.10	203 mm	3.78
Concrete fill finish (per mm thickness)	0.023	305 mm	5.51
Hardwood flooring, 22 mm	0.19	406 mm	7.42
Linoleum or asphalt tile, 6 mm	0.05	Hollow concrete masonry unit wythes:	
Marble and mortar on stone-concrete fill	1.58	Wythe thickness (in mm)	102
Slate (per mm thickness)	0.028	Density of unit (16.49 kN/m ³)	1.1
Solid flat tile on 25 mm mortar base	1.10	No grout	1.29
Subflooring, 19 mm	0.14	1219 mm	1.65
Terrazzo (38 mm) directly on slab	0.91	1016 mm	1.48
Terrazzo (25 mm) on stone-concrete fill	1.53	813 mm	1.92
Terrazzo (25 mm), 51 mm stone concrete	1.53	610 mm	1.58
Wood block (76 mm) on mastic, no fill	0.48	406 mm	1.63
Wood block (76 mm) on 13 mm mortar base	0.77	Full grout	1.77
FLOORS. WOOD-JOIST (NO PLASTER)		Density of unit (19.64 kN/m ³)	2.01
DOUBLE WOOD FLOOR		Full grout	2.73
Joint sizes		No grout	1.34
spacing		1219 mm	1.72
(mm)		1016 mm	1.58
(kN/m ²)		813 mm	1.63
0.24	610 mm	610 mm	2.15
0.29	spacing	610 mm	2.25
0.29	(kN/m ²)	406 mm	1.72
0.34	0.24	Full grout	2.44
0.38	0.24	Density of unit (21.21 kN/m ³)	2.11
0.34	0.29	No grout	2.78
	0.29	1219 mm	3.88
	0.34	1016 mm	2.15
	0.38	813 mm	2.39
	0.34	610 mm	2.92
	0.38	406 mm	3.11
	0.34	Full grout	2.68
	0.38	Density of unit (21.21 kN/m ³)	3.26
	0.34	No grout	1.87
	0.38	1219 mm	2.11
	0.34	1016 mm	2.82
	0.38	813 mm	1.68
	0.34	610 mm	1.55
	0.38	406 mm	2.39
	0.34	Full grout	1.72
	0.38	Density of unit (21.21 kN/m ³)	1.82
	0.34	No grout	1.96
	0.38	1219 mm	2.25
	0.34	1016 mm	3.06
	0.38	813 mm	4.17
	0.34	610 mm	2.59
	0.38	406 mm	3.02
	0.34	Full grout	1.55
	0.38	Density of unit (21.21 kN/m ³)	2.39
	0.34	No grout	1.72
	0.38	1219 mm	1.82
	0.34	1016 mm	1.96
	0.38	813 mm	2.25
	0.34	610 mm	3.06
	0.38	406 mm	4.17
	0.34	Full grout	2.59
	0.38	Density of unit (21.21 kN/m ³)	3.02
	0.34	No grout	1.68
	0.38	1219 mm	1.55
	0.34	1016 mm	2.39
	0.38	813 mm	1.72
	0.34	610 mm	1.82
	0.38	406 mm	1.96
	0.34	Full grout	2.25
	0.38	Density of unit (21.21 kN/m ³)	3.06
	0.34	No grout	4.17
	0.38	1219 mm	5.27
	0.34	1016 mm	6.37
	0.38	813 mm	2.59
	0.34	610 mm	3.02
	0.38	406 mm	1.55
	0.34	Full grout	2.39
	0.38	Density of unit (21.21 kN/m ³)	1.72
	0.34	No grout	1.82
	0.38	1219 mm	1.96
	0.34	1016 mm	2.25
	0.38	813 mm	3.06
	0.34	610 mm	4.17
	0.38	406 mm	2.59
	0.34	Full grout	3.02
	0.38	Density of unit (21.21 kN/m ³)	1.55
	0.34	No grout	2.39
	0.38	1219 mm	1.72
	0.34	1016 mm	1.82
	0.38	813 mm	1.96
	0.34	610 mm	2.25
	0.38	406 mm	3.06
	0.34	Full grout	4.17
	0.38	Density of unit (21.21 kN/m ³)	5.27
	0.34	No grout	6.37
	0.38	1219 mm	2.59
	0.34	1016 mm	3.02
	0.38	813 mm	1.55
	0.34	610 mm	2.39
	0.38	406 mm	1.72
	0.34	Full grout	1.82
	0.38	Density of unit (21.21 kN/m ³)	1.96
	0.34	No grout	2.25
	0.38	1219 mm	3.06
	0.34	1016 mm	4.17
	0.38	813 mm	2.59
	0.34	610 mm	3.02
	0.38	406 mm	1.55
	0.34	Full grout	2.39
	0.38	Density of unit (21.21 kN/m ³)	1.72
	0.34	No grout	1.82
	0.38	1219 mm	1.96
	0.34	1016 mm	2.25
	0.38	813 mm	3.06
	0.34	610 mm	4.17
	0.38	406 mm	2.59
	0.34	Full grout	3.02
	0.38	Density of unit (21.21 kN/m ³)	1.55
	0.34	No grout	2.39
	0.38	1219 mm	1.72
	0.34	1016 mm	1.82
	0.38	813 mm	1.96
	0.34	610 mm	2.25
	0.38	406 mm	3.06
	0.34	Full grout	4.17
	0.38	Density of unit (21.21 kN/m ³)	5.27
	0.34	No grout	6.37
	0.38	1219 mm	2.59
	0.34	1016 mm	3.02
	0.38	813 mm	1.55
	0.34	610 mm	2.39
	0.38	406 mm	1.72
	0.34	Full grout	1.82
	0.38	Density of unit (21.21 kN/m ³)	1.96
	0.34	No grout	2.25
	0.38	1219 mm	3.06
	0.34	1016 mm	4.17
	0.38	813 mm	2.59
	0.34	610 mm	3.02
	0.38	406 mm	1.55
	0.34	Full grout	2.39
	0.38	Density of unit (21.21 kN/m ³)	1.72
	0.34	No grout	1.82
	0.38	1219 mm	1.96
	0.34	1016 mm	2.25
	0.38	813 mm	3.06
	0.34	610 mm	4.17
	0.38	406 mm	2.59
	0.34	Full grout	3.02
	0.38	Density of unit (21.21 kN/m ³)	1.55
	0.34	No grout	2.39
	0.38	1219 mm	1.72
	0.34	1016 mm	1.82
	0.38	813 mm	1.96
	0.34	610 mm	2.25
	0.38	406 mm	3.06
	0.34	Full grout	4.17
	0.38	Density of unit (21.21 kN/m ³)	5.27
	0.34	No grout	6.37
	0.38	1219 mm	2.59
	0.34	1016 mm	3.02
	0.38	813 mm	1.55
	0.34	610 mm	2.39
	0.38	406 mm	1.72
	0.34	Full grout	1.82
	0.38	Density of unit (21.21 kN/m ³)	1.96
	0.34	No grout	2.25
	0.38	1219 mm	3.06
	0.34	1016 mm	4.17
	0.38	813 mm	2.59
	0.34	610 mm	3.02
	0.38	406 mm	1.55
	0.34	Full grout	2.39
	0.38	Density of unit (21.21 kN/m ³)	1.72
	0.34	No grout	1.82
	0.38	1219 mm	1.96
	0.34	1016 mm	2.25
	0.38	813 mm	3.06
	0.34	610 mm	4.17
	0.38	406 mm	2.59
	0.34	Full grout	3.02
	0.38	Density of unit (21.21 kN/m ³)	1.55
	0.34	No grout	2.39
	0.38	1219 mm	1.72
	0.34	1016 mm	1.82
	0.38	813 mm	1.96
	0.34	610 mm	2.25
	0.38	406 mm	3.06
	0.34	Full grout	4.17
	0.38	Density of unit (21.21 kN/m ³)	5.27
	0.34	No grout	6.37
	0.38	1219 mm	2.59
	0.34	1016 mm	3.02
	0.38	813 mm	1.55
	0.34	610 mm	2.39
	0.38	406 mm	1.72
	0.34	Full grout	1.82
	0.38	Density of unit (21.21 kN/m ³)	1.96
	0.34	No grout	2.25
	0.38	1219 mm	3.06
	0.34	1016 mm	4.17
	0.38	813 mm	2.59
	0.34	610 mm	3.02
	0.38	406 mm	1.55
	0.34	Full grout	2.39
	0.38	Density of unit (21.21 kN/m ³)	1.72
	0.34	No grout	1.82
	0.38	1219 mm	1.96
	0.34	1016 mm	2.25
	0.38	813 mm	3.06
	0.34	610 mm	4.17
	0.38	406 mm	2.59
	0.34	Full grout	3.02
	0.38	Density of unit (21.21 kN/m ³)	1.55
	0.34	No grout	2.39
	0.38	1219 mm	1.72
	0.34	1016 mm	1.82
	0.38	813 mm	1.96
	0.34	610 mm	2.25
	0.38	406 mm	3.06
	0.34	Full grout	4.17
	0.38	Density of unit (21.21 kN/m ³)	5.27
	0.34	No grout	6.37
	0.38	1219 mm	2.59
	0.34	1016 mm	3.02
	0.38	813 mm	1.55
	0.34	610 mm	2.39
	0.38	406 mm	1.72
	0.34	Full grout	1.82
	0.38	Density of unit (21.21 kN/m ³)	1.96
	0.34	No grout	2.25
	0.38	1219 mm	3.06
	0.34	1016 mm	4.17
	0.38	813 mm	2.59
	0.34	610 mm	3.02
	0.38	406 mm	1.55
	0.34	Full grout	2.39
	0.38	Density of unit (21.21 kN/m ³)	1.72
	0.34	No grout	1.82
	0.38	1219 mm	1.96
	0.34	1016 mm	2.25
	0.38	813 mm	3.06
	0.34	610 mm	4.17
	0.38	406 mm	2.59
	0.34	Full grout	3.02
	0.38	Density of unit (21.21 kN/m ³)	1.55
	0.34	No grout	2.39
	0.38	1219 mm	1.72
	0.34	1016 mm	1.82
	0.38	813 mm	1.96
	0.34	610 mm	2.25
	0.38	406 mm	3.06
	0.34	Full grout	4.17
	0.38	Density of unit (21.21 kN/m ³)	5.27
	0.34	No grout	6.37
	0.38	1219 mm	2.59
	0.34	1016 mm	3.02
	0.38	813 mm	1.55
	0.34	610 mm	2.39
	0.38	406 mm	1.72
	0.34	Full grout	1.82
	0.38	Density of unit (21.21 kN/m ³)	1.96
	0.34	No grout	2.25
	0.38	1219 mm	3.06
	0.34	1016 mm	4.17
	0.38	813 mm	2.59
	0.34	610 mm	3.02
	0.38	406 mm	1.55
	0.34	Full grout	2.39
	0.38	Density of unit (21.21 kN/m ³)	1.72
	0.34	No grout	1.82
	0.38	1219 mm	1.96
	0.34	1016 mm	2.25

Table 3: Minimum Densities for Design Loads from Materials

Material	Density (kN/m ³)	Material	Density (kN/m ³)
Aluminum	26.71	Lime	
Bituminous products		Hydrated, loose	5.03
Asphaltum	12.73	Hydrated, compacted	7.07
Graphite	21.21	Masonry, ashlar stone	
Paraffin	8.80	Granite	25.92
Petroleum, crude	8.64	Limestone, crystalline	25.92
Petroleum, refined	7.86	Limestone, oolitic	21.21
Petroleum, benzine	7.23	Marble	27.18
Petroleum, gasoline	6.60	Sandstone	22.62
Pitch	10.84	Masonry, brick	
Tar	11.78	Hard (low absorbtion)	20.42
Brass	82.63	Medium (medium absorbtion)	18.07
Bronze	86.72	Soft (high absorbtion)	15.71
Cast-stone masonry (cement, stone, sand)	22.62	Masonry, concrete*	
Cement, portland. loose	14.14	Lightweight units	16.50
Ceramic tile	23.57	Medium weight units	19.64
Charcoal	1.89	Normal weight units	21.21
Cinder fill	8.95	Masonry grout	21.99
Cinders, dry, in bulk	7.07	Masonry, rubble stone	
Coal		Granite	24.04
Anthracite, piled	8.17	Limestone, crystalline	23.09
Bituminous, piled	7.38	Limestone, oolitic	21.68
Lignite, piled	7.38	Marble	24.51
Peat, dry, piled	3.61	Sandstone	21.52
Concrete, plain		Mortar, cement or lime	20.42
Cinder	16.97	Particleboard	7.07
Expanded-slag aggregate	15.71	Plywood	5.66
Haydite (burned-clay aggregate)	14.14	Riprap (not submerged)	
Slag	20.74	Limestone	13.04
Stone (including gravel)	22.62	Sandstone	14.14
Vermiculite and perlite aggregate, nonload-bearing	3.93 – 7.86	Sand	
Other light aggregate, load-bearing	11.0 – 16.5	Clean and dry	14.14
Concrete, reinforced		River, dry	16.65
Cinder	17.44	Slag	
Slag	21.68	Bank	11.00
Stone (including gravel)	23.57	Bank screenings	16.97
Copper	87.35	Machine	15.08
Cork, compressed	2.20	Sand	8.17
Earth (not submerged)		Slate	27.02
Clay, dry	9.90	Steel, cold-drawn	77.29
Clay, damp	17.44	Stone, quarried, piled	
Clay and gravel, dry	15.71	Basalt, granite, gneiss	15.08
Silt, moist, loose	12.25	Limestone, marble, quartz	14.92
Silt, moist, packed	15.08	Sandstone	12.88
Silt, flowing	16.97	Shale	14.45
Sand and gravel, dry, loose	15.71	Greenstone, hornblende	16.81
Sand and gravel, dry, packed	17.28	Terra Cotta, architectural	
Sand and gravel, wet	18.85	Voids filled	18.85
Earth (submerged)		Voids unfilled	11.31
Clay	12.57	Tin	72.11
Soil	11.00	Water	
River mud	14.14	Fresh	9.74
Sand or gravel	9.43	Sea	10.05
Sand or gravel and clay	10.21	Wood, seasoned	
Glass	25.14	Ash, commercial white	6.44
Gravel, dry	16.34	Cypress, southern	5.34
Gypsum, loose	11.00	Fir, Douglas, coast region	5.34
Gypsum, wallboard	7.86	Hem fir	4.40
Ice	8.95	Oak, commercial reds and whites	7.38
Iron		Pine, southern yellow	5.81
Cast	70.70	Redwood	4.40
Wrought	75.41	Spruce, red, white, and Stika	4.56
Lead	111.54	Western hemlock	5.03

- **Live Loads:**
 - Vertical loads due to human occupancy, snow, rain ponding, furniture, partition walls and moveable equipment.
 - Horizontal (lateral) loads due to wind, earthquake, water pressure, blast/explosion, collision, etc.
 - Loads produced through construction or occupancy of the structure.
 - They can be caused by weights of objects temporarily placed on a structure, moving vehicles, or natural forces.
 - Can be categorized to:
 - Occupancy loads of buildings (ASCE-7)
 - Traffic loads for bridges (AASHTO)
 - Impact loads
 - Applied over a very short period of time
 - Have greater effect on the structure
 - Moving loads:
 - Dynamic significance.
 - Change over a period of time.
 - Codes have established its data based on studying the history of such loads.
 - Types of live loads:

✓ Building Loads	✓ Snow Load
✓ Highway Bridge Loads	✓ Earthquake Loads
✓ Railroad Bridge Loads	✓ Hydrostatic Pressure
✓ Impact Loads	✓ Soil Pressure
✓ Wind Loads	✓ Other Environmental Loads

- Floors are assumed to be under uniform live loads which depend on the purpose for which the building is designed.
- These loads are usually tabulated in adapted code.
- These values include some protection against overloading, emergency situations, construction loads, and serviceability requirements due to vibration.
- Environmental loads:
 - Snow and ice loads
 - Rain loads
 - Accumulation of rainwater on flat roof (ponding)
 - Avoid by providing (2%) slope and design adequate drainage.
 - Wind loads
 - Causes forces, vibrations, and (in some cases) instability
 - Depends on
 - Wind speed
 - Mass density of the air
 - Location of the structure
 - Geometry of the structure
 - Vibrational characteristics of the system



- Earthquake loads
 - It is the common dynamic loading associated with the ground movement
 - It affects the base of the structure
 - The rest of the structure is affected due to inertia
 - Creates horizontal shear forces and deflections
 - Depends on
 - Nature of the ground movement
 - The inertia response of the structure

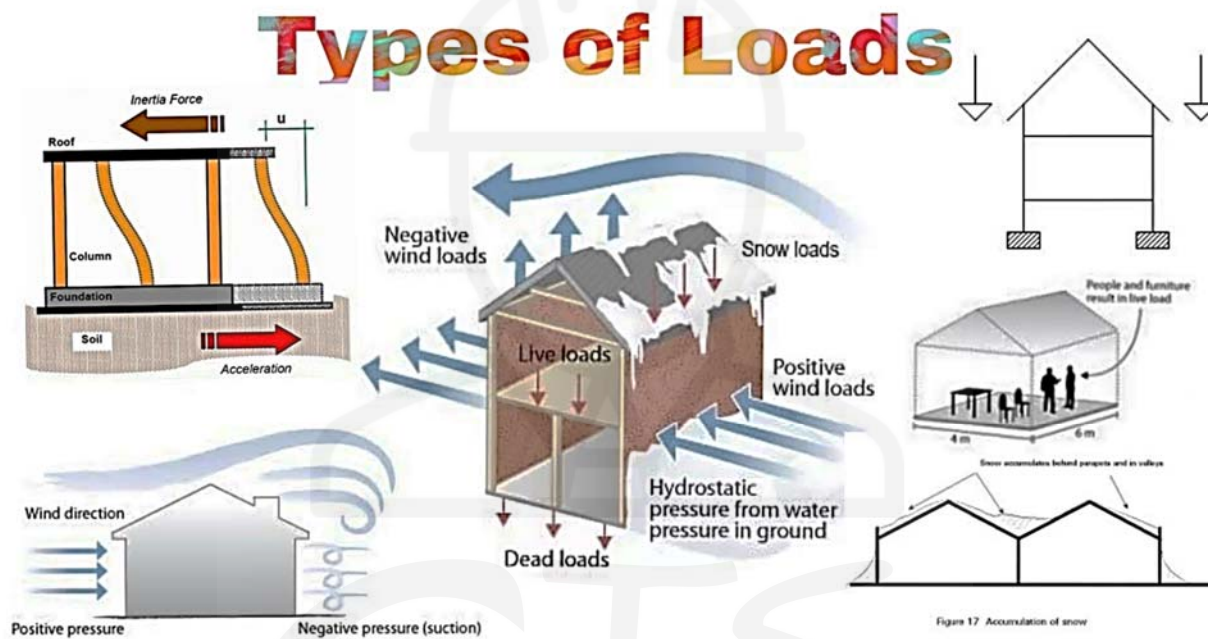

Figure 1-14: Types of loads

Minimum Uniformly Distributed Live Loads, L_o , and Minimum Concentrated Live Loads

Occupancy or Use	Uniform kN/m ²	Concentrated kN
Apartments (see Residential)		
Access floor systems		
Office use	2.40	8.90
Computer use	4.79	8.90
Armories and drill rooms	7.18 a	
Assembly areas and theaters		
Fixed seats (fastened to floor)	2.87 a	
Lobbies	4.79 a	
Movable seats	4.79 a	
Platforms (assembly)	4.79 a	
Stage floors	7.18 a	
Balconies and decks		
(1.5 times the live load for the occupancy served. Not required to exceed 100 psf (4.79 kN/m ²))		
On one- and two-family residences only.	4.79	
(not exceeding 100 ft ² 19.3 m ²)	2.87	
Catwalks for maintenance access	1.92	
Corridors		
First floor	4.79	
Other floors, same as occupancy served except as indicated		
Dining rooms and restaurants	4.79 a	
Dwellings (see Residential)		
Elevator machine room grating (on area of 2 in. by 2 in. (50 mm by 50 mm))		1.33
Finish light floor plate construction (on area of 1 in. by 1 in. (25 mm by 25 mm))		0.89
Fire escapes	4.79	
On single-family dwellings only	1.92	
Fixed ladders		See Section 4.5
Garages		
Passenger vehicles	1.92 a,b	
Trucks and buses see notes	c	
Grandstands (see stadiums and arenas, bleachers)		
Handrails, guardrails, and grab bars		See section 4.5
Helipads	2.87 d,e	
Hospitals		
Operating rooms, laboratories	2.87	
Patient rooms	1.92	e,f,g
Corridors above first floor	3.83	
Hotels (see Residential)		
Libraries		
Reading rooms	2.87	4.45
Stack rooms	7.18 a,h	4.45
Corridors above first floor	3.83	4.45
Manufacturing		
Light	6.00 a	4.45
Heavy	11.97 a	4.45
Marquees	3.59	

Occupancy or Use	Uniform kN/m ²	Concentrated kN
Office buildings		
File and computer rooms shall be designed for heavier loads based on anticipated occupancy		
Lobbies and first-floor corridors	4.79	8.90
Offices	2.40	8.90
Corridors above first floor	3.83	13.40
Penal institutions	1.92	
Cell Blocks		
Corridors	4.79	8.90
Recreational uses		
Gymnasiums	4.79 a	
Bowling alleys, poolrooms, and similar uses	3.59 a	
Dance halls and ballrooms	4.79 a	
Reviewing stands, grandstands, and bleachers	4.79 a,k	
Stadiums and arenas with fixed seats (fastened to the floor)	2.87 a,k	
Residential		
One- and two-family dwellings		
Uninhabitable attics without storage	0.48 l	
Uninhabitable attics with storage	0.96 m	
Habitable attics and sleeping areas	1.44	
All other areas except stairs	1.92	
All other residential occupancies (ex. Hotels)		
Private rooms and corridors serving them	1.92	
Public rooms and corridors serving them	4.79 a	
Reviewing stands, grandstands, and bleachers	4.79	
Roofs		
Ordinary flat, pitched, and curved roofs	0.96 n	
Roofs used for roof gardens	4.79	
Roofs used for promenade purposes	2.87 a,k	
Roofs used for assembly purposes	Same as occupancy served	
Roofs used for other occupancies	o	o
Awnings and canopies		
Fabric construction supported by a lightweight rigid skeleton structure	0.24 non-reducible	1.33 applied to skeleton structure
Screen enclosure support frame	0.24 non-reducible and applied to the roof frame members only, not the screen	0.89 applied to support roof frame members only;
All other construction	0.96	
Primary roof members, exposed to a work floor		
Single panel point of lower chord of roof trusses or any point along primary structural members supporting roofs over manufacturing, storage warehouses, and repair garages		8.90
All other primary roof members		1.33
All roof surfaces subject to maintenance workers		1.33
Schools		
Classrooms	1.92	4.45
Corridors above first floor	3.83	4.45
First-floor corridors	4.79	4.45

Occupancy or Use	Uniform kN/m ²	Concentrated kN
Scuttles, skylight ribs, and accessible ceilings		0.89
Sidewalks, vehicular driveways, and yards subject to trucking	11.97 a,p	35.60 q
Stairs and exit ways	4.79	r
One- and two-family dwellings only	1.92	r
Storage areas above ceilings	0.96	
Storage warehouses (shall be designed for heavier loads if required for anticipated storage)		
Light	6.00 a	300 r
Heavy	11.97 a	300 r
Stores		
Retail		
First floor	4.79	4.45
Upper floors	3.59	4.45
Wholesale, all floors	6.00 a	4.45
Vehicle barriers		See Section 4.5
Walkways and elevated platforms (other than exit ways)	2.87	
Yards and terraces, pedestrian	4.79 a	

Notes:

- (a) Live load reduction for this use is not permitted by Section 4.7 unless specific exceptions apply.
- (b) Floors in garages or portions of a building used for the storage of motor vehicles shall be designed for the uniformly distributed live loads of Table 4-1 or the following concentrated load: (1) for garages restricted to passenger vehicles accommodating not more than nine passengers, 3,000 lb (13.35 kN) acting on an area of 4.5 in. by 4.5 in. (114 mm by 114 mm); and (2) for mechanical parking structures without slab or deck that are used for storing passenger vehicles only, 2,250 lb (10 kN) per wheel.
- (c) Design for trucks and buses shall be per AASHTO LRFD Bridge Design Specifications; however, provisions for fatigue and dynamic load allowance are not required to be applied.
- (d) Uniform load shall be 40 psf (1.92 kN/m²) where the design basis helicopter has a maximum take-off weight of 3,000 lbs. (13.35 kN) or less. This load shall not be reduced.
- (e) Labeling of helicopter capacity shall be as required by the authority having jurisdiction.
- f Two single concentrated loads, 8 ft (2.44 m) apart shall be applied on the landing area (representing the helicopter's two main landing gear, whether skid type or wheeled type), each having a magnitude of 0.75 times the maximum take-off weight of the helicopter and located to produce the maximum load effect on the structural elements under consideration. The concentrated loads shall be applied over an area of 8 in. by 8 in. (200 mm by 200 mm) and shall not be concurrent with other uniform or concentrated live loads.
- (g) A single concentrated load of 3,000 lbs. (13.35 kN) shall be applied over an area 4.5 in. by 4.5 in. (114 mm by 114 mm), located so as to produce the maximum load effects on the structural elements under consideration. The concentrated load need not be assumed to act concurrently with other uniform or concentrated live loads.
- h The loading applies to stack room floors that support non-mobile, double-faced library book stacks subject to the following limitations: (1) The nominal book stack unit height shall not exceed 90 in. (2,290 mm); (2) the nominal shelf depth shall not exceed 12 in. (305 mm) for each face; and (3) parallel rows of double-faced book stacks shall be separated by aisles not less than 36 in. (914 mm) wide.
- (k) In addition to the vertical live loads, the design shall include horizontal swaying forces applied to each row of the seats as follows: 24 lb per linear ft of seat applied in a direction parallel to each row of seats and 10 lb per linear ft of seat applied in a direction perpendicular to each row of seats. The parallel and perpendicular horizontal swaying forces need not be applied simultaneously.
- (l) Uninhabitable attic areas without storage are those where the maximum clear height between the joist and rafter is less than 42 in. (1,067 mm), or where there are not two or more adjacent trusses with web configurations capable of accommodating an assumed rectangle 42 in. (1,067 mm) in height by 24 in. (610 mm) in width, or greater, within the plane of the trusses. This live load need not be assumed to act concurrently with any other live load requirement.
- (m) Uninhabitable attic areas with storage are those where the maximum clear height between the joist and rafter is 42 in. (1,067 mm) or greater, or where there are two or more adjacent trusses with web configurations capable of accommodating an assumed rectangle 42 in. (1,067 mm) in height by 24 in. (610 mm) in width, or greater, within

the plane of the trusses. At the trusses, the live load need only be applied to those portions of the bottom chords where both of the following conditions are met:

- i. The attic area is accessible from an opening not less than 20 in. (508 mm) in width by 30 in. (762 mm) in length that is located where the clear height in the attic is a minimum of 30 in. (762 mm); and
- ii. The slope of the truss bottom chord is no greater than 2 units vertical to 12 units horizontal (9.5% slope).

The remaining portions of the bottom chords shall be designed for a uniformly distributed non-concurrent live load of not less than 10 lb/ft² (0.48 kN/m²).

(n) Where uniform roof live loads are reduced to less than 20 lb/ft² (0.96 kN/m²) in accordance with Section 4.8.1 and are applied to the design of structural members arranged so as to create continuity, the reduced roof live load shall be applied to adjacent spans or to alternate spans, whichever produces the greatest unfavorable load effect.

(o) Roofs used for other occupancies shall be designed for appropriate loads as approved by the authority having jurisdiction.

(p) Other uniform loads in accordance with an approved method, which contains provisions for truck loadings, shall also be considered where appropriate.

(q) The concentrated wheel load shall be applied on an area of 4.5 in. by 4.5 in. (114 mm by 114 mm).

(r) Minimum concentrated load on stair treads (on area of 2 in. by 2 in. [50 mm by 50 mm]) is to be applied non-concurrent with the uniform load.

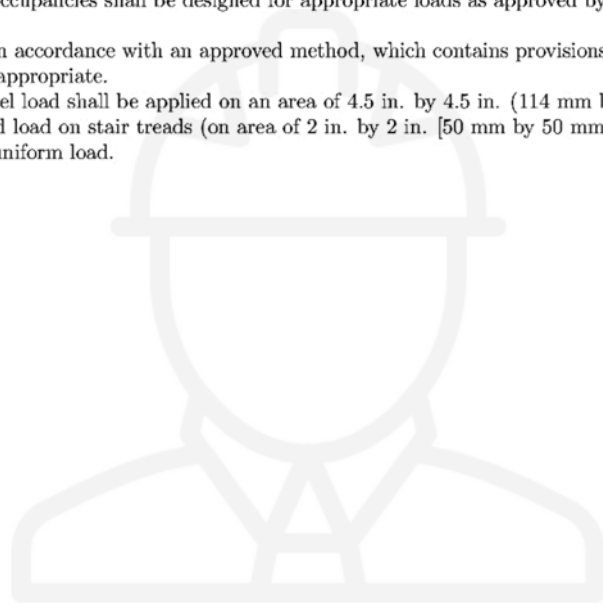

CTS
CIVIL

Chapter (2): Beam Analysis

2.1 Loading on Beams:

2.2 Loading Types:

The loading on beam can be categorized to (Figure 2-1):

- Concentrated Load
 - Concentrated Force
 - Concentrated Moment
- Distributed Load
 - Uniformly Distributed Load (UDL)
 - Linearly Varying Distributed Load (LVDU)

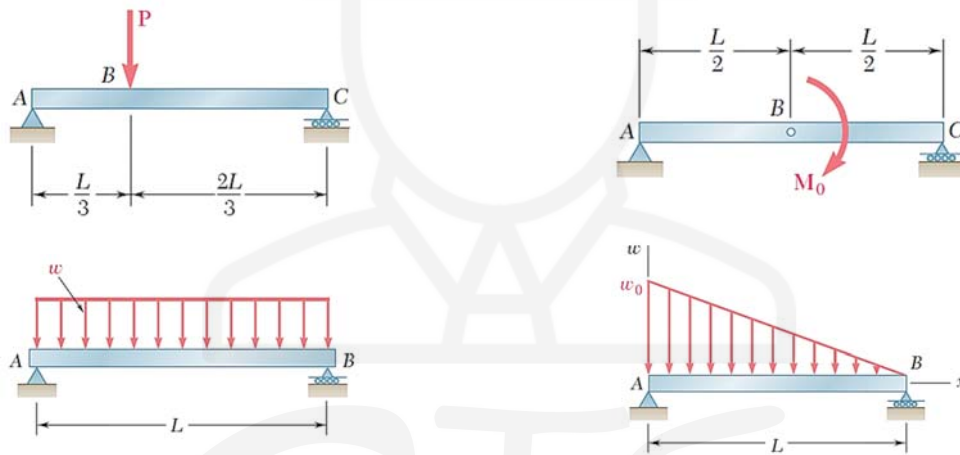

Figure 2-1: Loading types on beams

2.3 Support Types:

Supports on beams transfer the loads to the following structural member (usually a column)

Three major types (Figure 2-2):

- Roller → Vertical reaction only
- Hinge → Vertical and horizontal reaction
- Fixed → Vertical and horizontal reaction + a bending moment







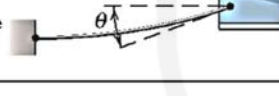
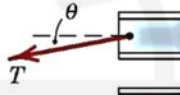

MODELING THE ACTION OF FORCES IN TWO-DIMENSIONAL ANALYSIS	
Type of Contact and Force Origin	Action on Body to Be Isolated
<p>1. Flexible cable, belt, chain, or rope</p> <p>Weight of cable negligible </p> <p>Weight of cable not negligible </p>	 <p>Force exerted by a flexible cable is always a tension away from the body in the direction of the cable.</p> 
<p>2. Smooth surfaces</p> 	 <p>Contact force is compressive and is normal to the surface.</p>
<p>3. Rough surfaces</p> 	 <p>Rough surfaces are capable of supporting a tangential component F (frictional force) as well as a normal component N of the resultant contact force R.</p>
<p>4. Roller support</p> 	 <p>Roller, rocker, or ball support transmits a compressive force normal to the supporting surface.</p> 
<p>5. Freely sliding guide</p> 	 <p>Collar or slider free to move along smooth guides; can support force normal to guide only.</p> 

Figure 2-2: Beam reaction types

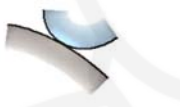
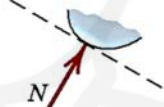

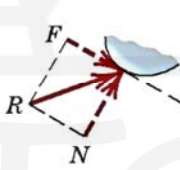
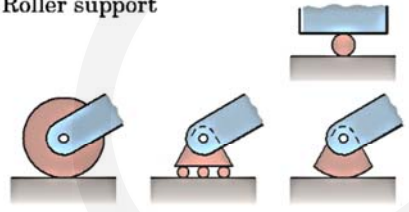
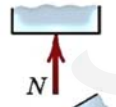

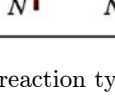

MODELING THE ACTION OF FORCES IN TWO-DIMENSIONAL ANALYSIS (cont.)	
Type of Contact and Force Origin	Action on Body to Be Isolated
<p>6. Pin connection</p> 	<p>Pin free to turn  A freely hinged pin connection is capable of supporting a force in any direction in the plane normal to the pin axis. We may either show two components R_x and R_y or a magnitude R and direction θ.</p> <p>Pin not free to turn  A pin not free to turn also supports a couple M.</p>
<p>7. Built-in or fixed support</p> 	 <p>A built-in or fixed support is capable of supporting an axial force F, a transverse force V (shear force), and a couple M (bending moment) to prevent rotation.</p>
<p>8. Gravitational attraction</p> 	 <p>The resultant of gravitational attraction on all elements of a body of mass m is the weight $W = mg$ and acts toward the center of the earth through the center mass G.</p>
<p>9. Spring action</p> 	 <p>Spring force is tensile if spring is stretched and compressive if compressed. For a linearly elastic spring the stiffness k is the force required to deform the spring a unit distance.</p>

Figure 2-3: Beam reaction types (Continued)

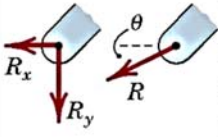
2.4 Beam Types:

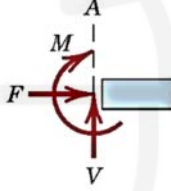
Beams can be divided into (Figure 2-4):

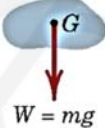
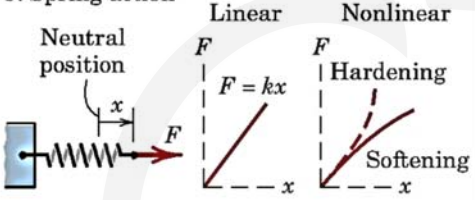
- **Statically determinate beams:**
 - Simply supported beams
 - One-sided over-hanging beam
 - Two-sided over-hanging beam
 - Cantilever beam
- **Statically indeterminate beams:**
 - Continuous beam
 - End-supported cantilever
 - Fixed at both ends

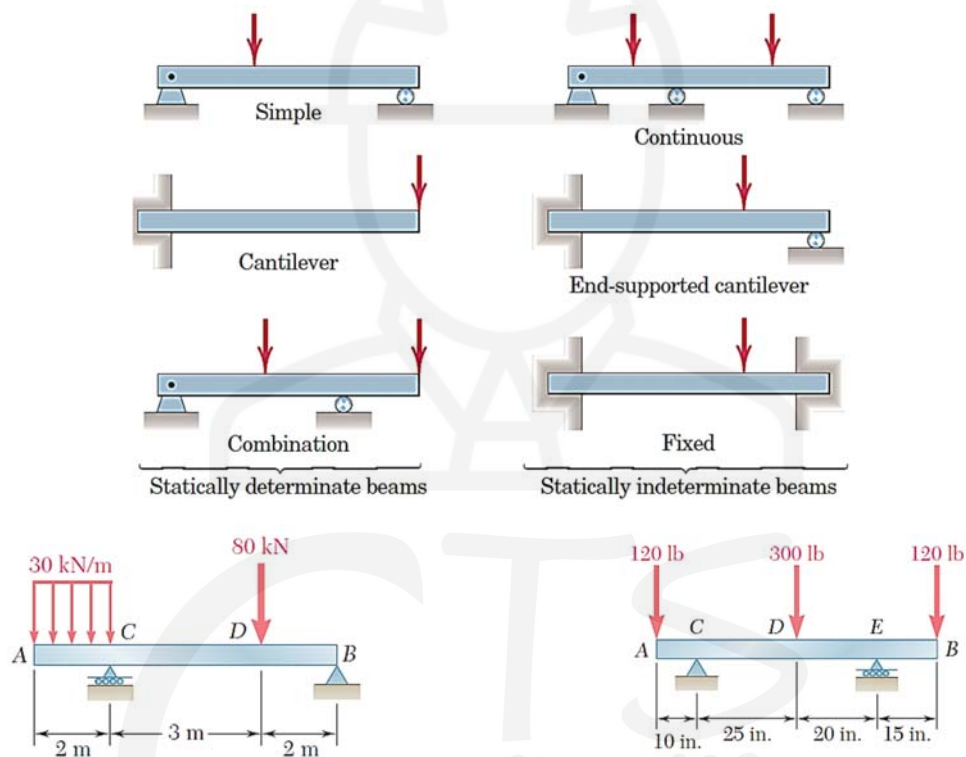

Figure 2-4: Beam types

2.5 Beam Reactions:

- Reactions on beams are developed due to the applications of the various loads on the beam.
- The reactions can be calculated (determinate beams only) by applying the three equations of equilibrium after drawing the free body diagram of the beam.
- The three equations of equilibrium are:

$$\begin{aligned}\sum F_x &= 0 \\ \sum F_y &= 0 \\ \sum M &= 0\end{aligned}\tag{2-1}$$

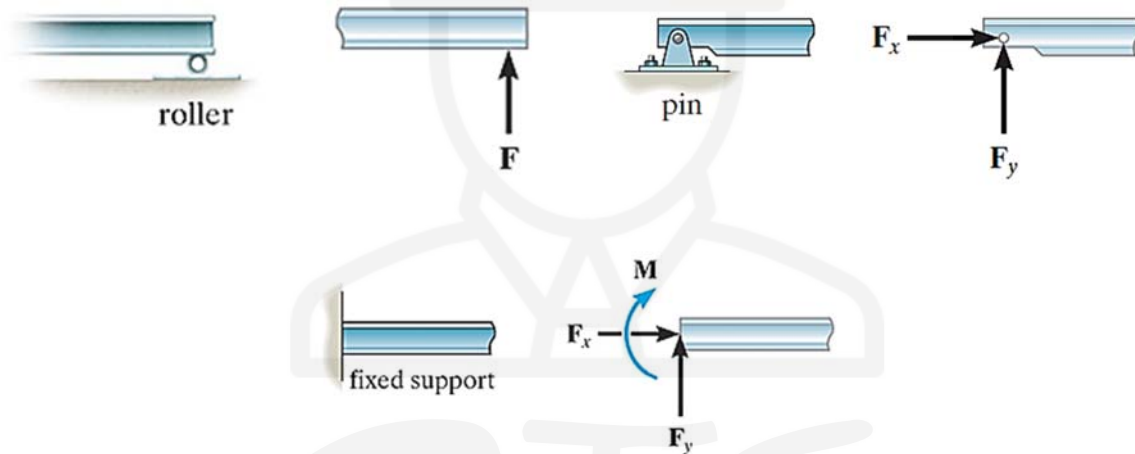

Figure 2-5: Beam reaction types

2.6 Sign Convention:

The positive sign convention used throughout the course is summarized in Figure 2-6. The positive x -direction is taken to the right, the positive y -direction is taken upward, and the positive moment is taken in the counter-clockwise direction.

Figure 2-6: The positive sign convention for forces and moment

2.7 Examples:

Example (1):

The 450-kg uniform I-beam supports the load shown. Determine the reactions at the supports.

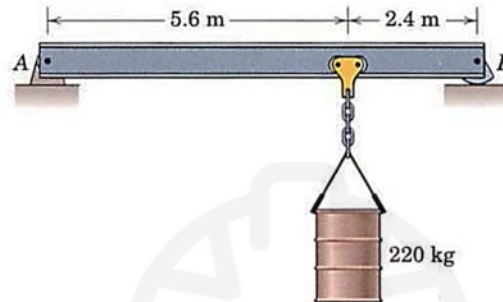

Solution:

3/6

From $\Sigma F_x = 0$, $A_x = 0$

$$\Sigma M_A = 0: -450(9.81)4 - 220(9.81)(5.6) + B_y(8) = 0, \quad B_y = 3720 \text{ N}$$

$$\Sigma F_y = 0: A_y - 450(9.81) - 220(9.81) + 3720 = 0$$

$$A_y = 2850 \text{ N}$$

Example (2):

Determine the reactions at A and B for the beam subjected to the uniform load distribution.

Ans. $R_A = 1.35 \text{ kN}$, $R_B = 0.45 \text{ kN}$

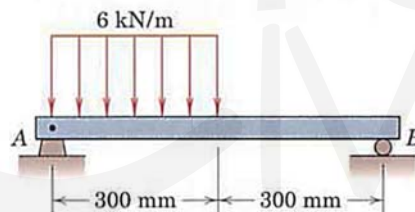

Solution:

5/93

$$R = 6(0.3) = 1.8 \text{ kN} @ \bar{x} = \frac{1}{2}(0.3) = 0.15 \text{ m}$$

$$\Sigma M_A = 0: R_B(0.6) - 1.8(0.15) = 0, \quad R_B = 0.45 \text{ kN}$$

$$\Sigma F_y = 0: 0.45 - 1.8 + R_A = 0, \quad R_A = 1.35 \text{ kN}$$

Example (3):

5/97 Determine the reactions at A for the cantilever beam subjected to the distributed and concentrated loads.
 Ans. $A_x = 0, A_y = 8 \text{ kN}, M_A = 21 \text{ kN}\cdot\text{m}$

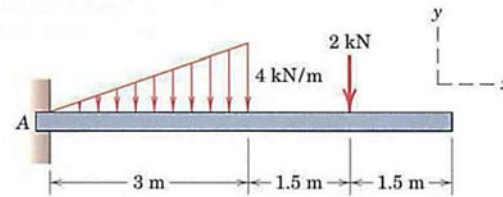

Solution:

5/97

$$R = \frac{1}{2}(3)(4) = 6 \text{ kN} @ \bar{x} = \frac{2}{3}(3) = 2 \text{ m}$$

$$\sum M_A = 0: M_A - 6(2) - 2(4.5) = 0, \quad M_A = 21 \text{ kN}\cdot\text{m}$$

$$\sum F_y = 0: A_y - 6 - 2 = 0, \quad A_y = 8 \text{ kN}$$

$$\sum F_x = 0: A_x = 0$$

Example (4):

5/100 Calculate the support reactions at A and B for the beam subjected to the two linearly varying load distributions.

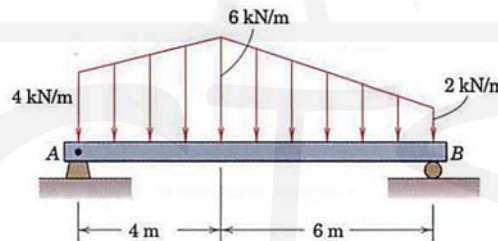

Solution:

5/100

$$R_1 = 4(4) = 16 \text{ kN}, \quad R_2 = \frac{1}{2}(2)(4) = 4 \text{ kN}$$

$$R_3 = \frac{1}{2}(4)(6) = 12 \text{ kN}, \quad R_4 = 2(6) = 12 \text{ kN}$$

$$\sum M_A = 0: 16(2) + 4\left(\frac{3}{2}4\right) + 12\left(4 + \frac{1}{2}6\right) + 12(4+3) - 10R_B = 0, \quad R_B = 19.87 \text{ kN}$$

$$+\uparrow \sum F = 0: R_A + 19.87 - (16 + 4 + 12 + 12) = 0$$

$$R_A = 24.1 \text{ kN}$$

Example (5):

5/94 Determine the reactions at the supports *A* and *B* for the beam loaded as shown.

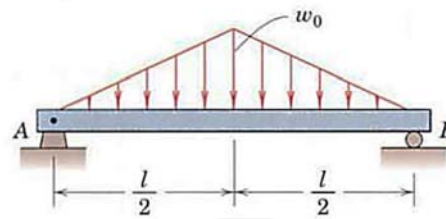

Solution:

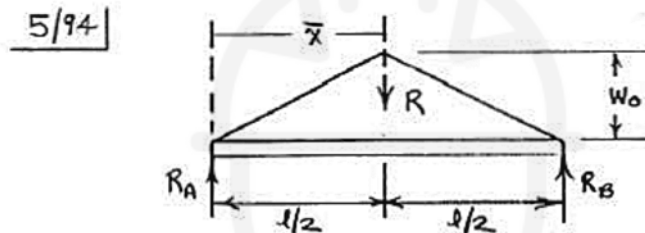

$$R = 2 \times \frac{1}{2} (w_0) \left(\frac{l}{2}\right) = \frac{1}{2} w_0 l \quad @ \quad \bar{x} = \frac{l}{2}$$

$$\sum M_A = 0: R_B(l) - \frac{1}{2} w_0 l \left(\frac{l}{2}\right) = 0, \quad R_B = \frac{1}{4} w_0 l$$

$$\sum F = 0: \frac{1}{4} w_0 l - \frac{1}{2} w_0 l + R_A = 0, \quad R_A = \frac{1}{4} w_0 l$$

2.8 Internal Forces in Beams:

Internal forces were defined as the forces and couples exerted on a portion of the structure by the rest of the structure.

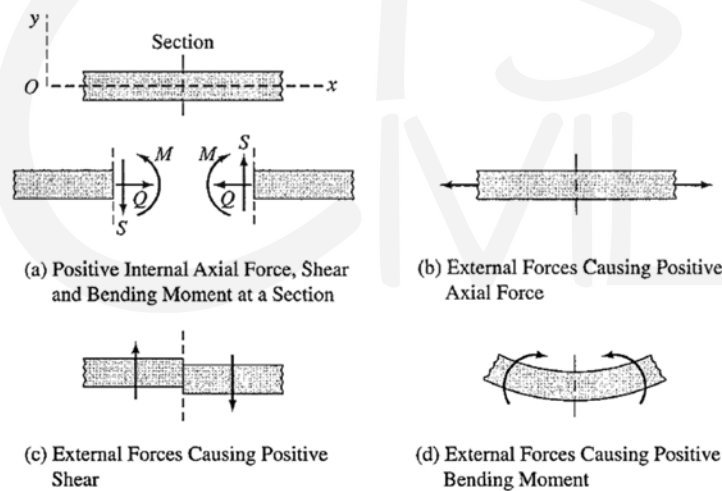

Figure 2-7: Sign convention for axial force, shear force, and bending moment

2.8.1 Procedure for Analysis

The procedure for determining internal forces at a specified location on a beam can be summarized as follows:

- 1- Compute the support reactions by applying the equations of equilibrium and condition (if any) to the free body of the entire beam. In cantilever beams, this step can be avoided by selecting the free, or externally unsupported, portion of the beam for analysis.
- 2- Pass a section perpendicular to the centroidal axis of the beam at the point where the internal forces are desired, thereby cutting the beam into two portions.
- 3- Although either of the two portions of the beam can be used for computing internal forces, we should select the portion that will require the least amount of computational effort, such as the portion that does not have any reactions acting on it or that has the least number of external loads and reactions applied to it.
- 4- Determine the axial force at the section by algebraically summing the components in the direction parallel to the axis of the beam of all the external loads and support reactions acting on the selected portion.
- 5- Determine the shear at the section by algebraically summing the components in the direction perpendicular to the axis of the beam of all the external loads and reactions acting on the selected portion.
- 6- Determine the bending moment at the section by algebraically summing the moments about the section of all the external forces plus the moments of any external couples acting on the selected portion.
- 7- To check the calculations, values of some or all of the internal forces may be computed by using the portion of the beam not utilized in steps 4 through 6. If the analysis has been performed correctly, then the results based on both left and right portions must be identical.

For the following examples, determine the axial forces, shears, and bending moments at points *A* and *B* of the structure shown.

2.8.2 Examples:

Example (1):

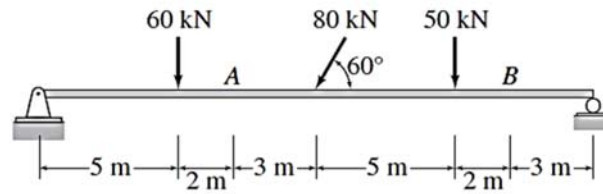

Solution:

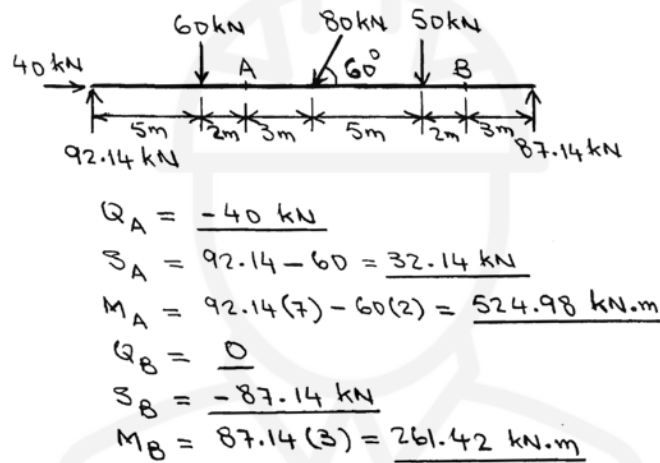

Example (2):

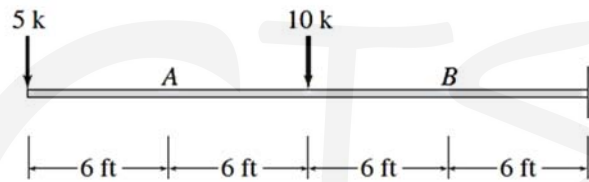

Solution:

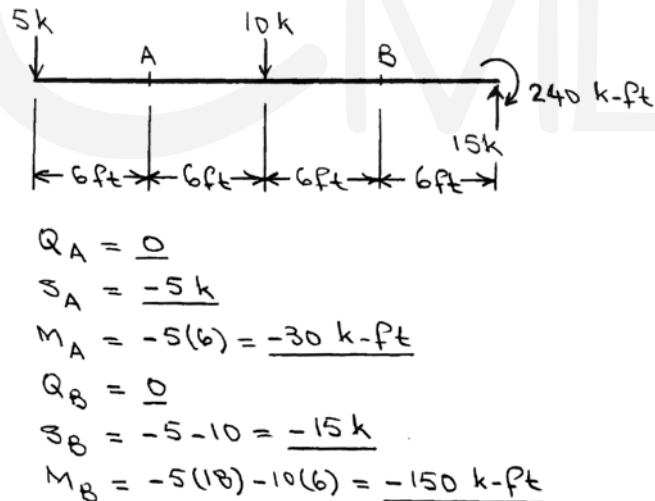

Example (3):

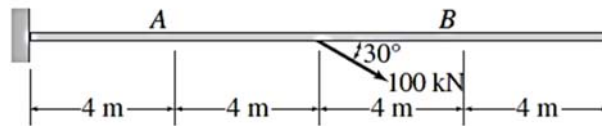

Solution:

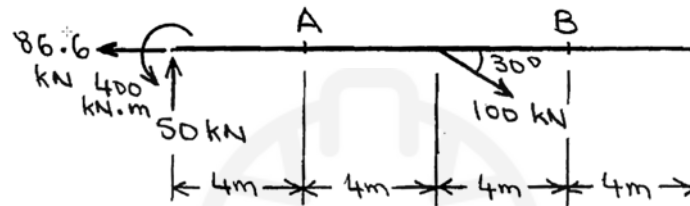

$$Q_A = 100 \cos 30^\circ = 86.6 \text{ kN}$$

$$S_A = 100 \sin 30^\circ = 50 \text{ kN}$$

$$M_A = -100 \sin 30^\circ (4) = -200 \text{ kN.m}$$

$$Q_B = 0$$

$$S_B = 0$$

$$M_B = 0$$

Example (4):

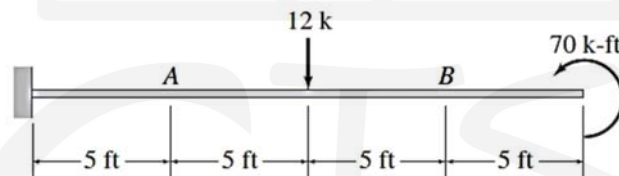

Solution:

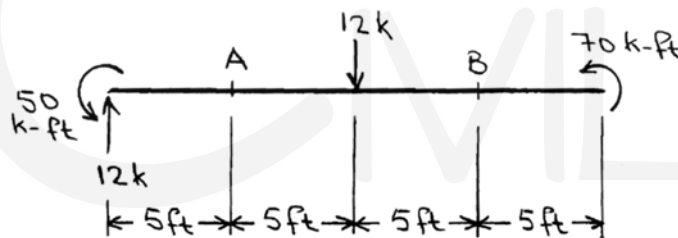

$$Q_A = 0$$

$$S_A = 12 \text{ k}$$

$$M_A = 12(5) - 50 = 10 \text{ k-ft}$$

$$Q_B = 0$$

$$S_B = 0$$

$$M_B = 70 \text{ k-ft}$$

Example (5):

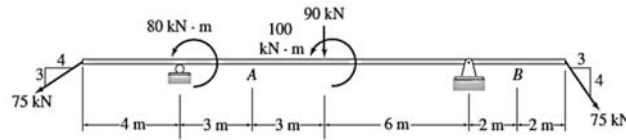

Solution:

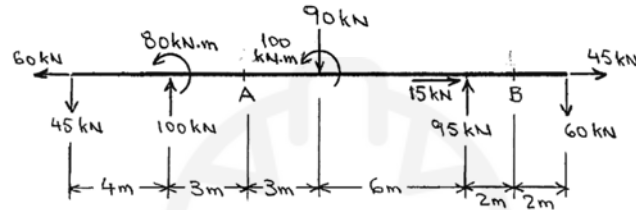

$$Q_A = 60 \text{ kN}$$

$$S_A = -45 + 100 = 55 \text{ kN}$$

$$M_A = -45(7) - 80 + 100(3) = -95 \text{ kN}\cdot\text{m}$$

$$Q_B = 45 \text{ kN}$$

$$S_B = 60 \text{ kN}$$

$$M_B = -60(2) = -120 \text{ kN}\cdot\text{m}$$

Example (6):

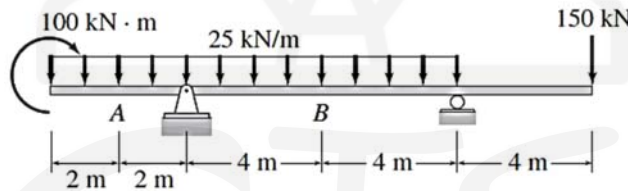

Solution:

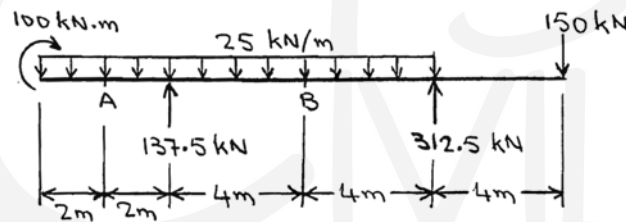

$$Q_A = 0$$

$$S_A = -25(2) = -50 \text{ kN}$$

$$M_A = 100 - 25(2)(1) = 50 \text{ kN}\cdot\text{m}$$

$$Q_B = 0$$

$$S_B = 150 - 312.5 + 25(4) = -62.5 \text{ kN}$$

$$M_B = -150(8) + 312.5(4) - 25(4)(2)$$

$$M_B = -150 \text{ kN}\cdot\text{m}$$

2.9 Shear Force and Bending Moment Diagrams:

2.9.1 Procedure for Analysis

The following step-by-step procedure can be used for constructing the shear and bending moment diagrams for beams by applying the foregoing relationships between the loads, the shears, and the bending moments.

- 1- Calculate the support reactions.
- 2- Construct the shear diagram as follows:
 - a. Determine the shear at the left end of the beam. If no concentrated load is applied at this point, the shear is zero at this point; go to step 2(b). Otherwise, the ordinate of the shear diagram at this point changes abruptly from zero to the magnitude of the concentrated force. Recall that an upward force causes the shear to increase, whereas a downward force causes the shear to decrease.
 - b. Proceeding from the point at which the shear was computed in the previous step toward the right along the length of the beam, identify the next point at which the numerical value of the ordinate of the shear diagram is to be determined. Usually, it is necessary to determine such values only at the ends of the beam and at points at which the concentrated forces are applied and where the load distributions change.
 - c. Determine the ordinate of the shear diagram at the point selected in step 2(b) (or just to the left of it, if a concentrated load acts at the point) by adding algebraically the area under the load diagram between the previous point and the point currently under consideration to the shear at the previous point (or just to the right of it, if a concentrated force act at the point).
 - d. Determine the shape of the shear diagram between the previous point and the point currently under consideration, (that the slope of the shear diagram at a point is equal to the load intensity at that point).
 - e. If no concentrated force is acting at the point under consideration, then proceed to step 2(f). Otherwise, determine the ordinate of the shear diagram just to the right of the point by adding algebraically the magnitude of the concentrated load to the shear just to the left of the point. Thus, the shear diagram at this point changes abruptly by an amount equal to the magnitude of the concentrated force.
 - f. If the point under consideration is not located at the right end of the beam, then return to step 2(b). Otherwise, the shear diagram has been completed. If the analysis has been carried out correctly, then the value of shear just to the right of the right end of the beam must be zero, except for the round-off errors.
- 3- Construct the bending moment diagram as follows:



- a. Determine the bending moment at the left end of the beam. If no couple is applied at this point, the bending moment is zero at this point; go to step 3(b). Otherwise, the ordinate of the bending moment diagram at this point changes abruptly from zero to the magnitude of the moment of the couple. Recall that a clockwise couple causes the bending moment to increase, whereas a counterclockwise couple causes the bending moment to decrease at its point of application.
- b. Proceeding from the point at which the bending moment was computed in the previous step toward the right along the length of the beam, identify the next point at which the numerical value of the ordinate of the bending moment diagram is to be determined. It is usually necessary to determine such values only at the points where the numerical values of shear were computed in step 2, where the couples are applied, and where the maximum and minimum values of bending moment occur. In addition to the points of application of couples, the maximum and minimum values of bending moment occur at points where the shear is zero. At a point of zero shear, if the shear changes from positive to the left to negative to the right, the slope of the bending moment diagram will change from positive to the left of the point to negative to the right of it; that is, the bending moment will be maximum at this point. Conversely, at a point of zero shear, where the shear changes from negative to the left to positive to the right, the bending moment will be minimum. For most common loading conditions, such as concentrated loads and uniformly and linearly distributed loads, the points of zero shear can be located by considering the geometry of the shear diagram. However, for some cases of linearly distributed loads, as well as for nonlinearly distributed loads, it becomes necessary to locate the points of zero shear by solving the expressions for shear.
- c. Determine the ordinate of the bending moment diagram at the point selected in step 3(b) (or just to the left of it, if a couple acts at the point) by adding algebraically the area under the shear diagram between the previous point and the point currently under consideration to the bending moment at the previous point (or just to the right of it, if a couple acts at the point).
- d. Determine the shape of the bending moment diagram between the previous point and the point currently under consideration (the slope of the bending moment diagram at a point is equal to the shear at that point).
- e. If no couple is acting at the point under consideration, then proceed to step 3(f). Otherwise, determine the ordinate of the bending moment diagram just to the right of the point by adding algebraically the magnitude of the moment of the couple to the bending moment just to the left of the point. Thus, the

bending moment diagram at this point changes abruptly by an amount equal to the magnitude of the moment of the couple.

- f. If the point under consideration is not located at the right end of the beam, then return to step 3(b). Otherwise, the bending moment diagram has been completed. If the analysis has been carried out correctly, then the value of bending moment just to the right of the right end of the beam must be zero, except for the round-off errors.

The foregoing procedure can be used for constructing the shear and bending moment diagrams by proceeding from the left end of the beam to its right end, as is currently the common practice. However, if we wish to construct these diagrams by proceeding from the right end of the beam toward the left, the procedure essentially remains the same except that downward forces must now be considered to cause increase in shear, counterclockwise couples are now considered to cause increase in bending moment, and vice versa.

For the following examples, draw the shear and bending moment diagrams and the qualitative deflected shape for the beam shown.

2.9.2 Examples:

Example (1):

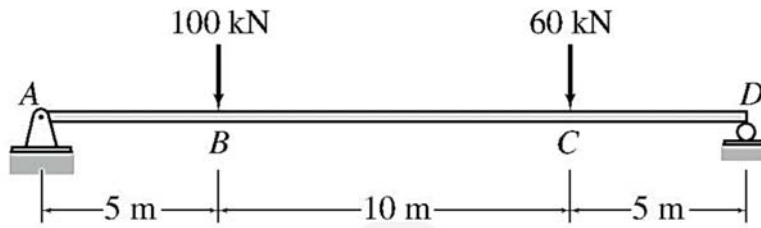

Solution:

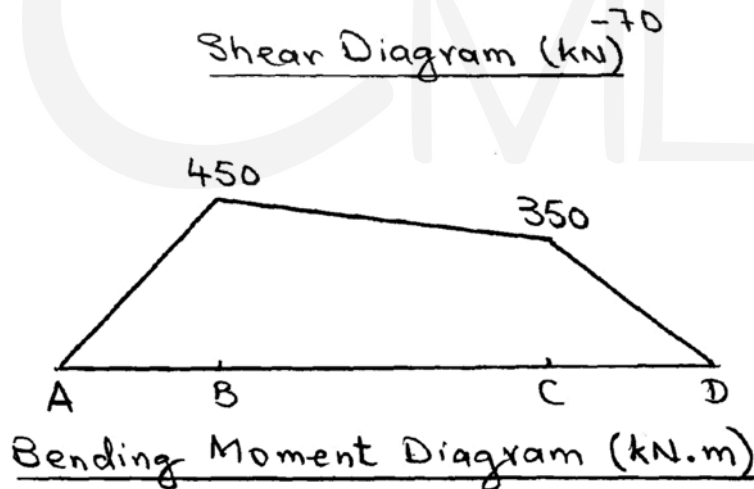
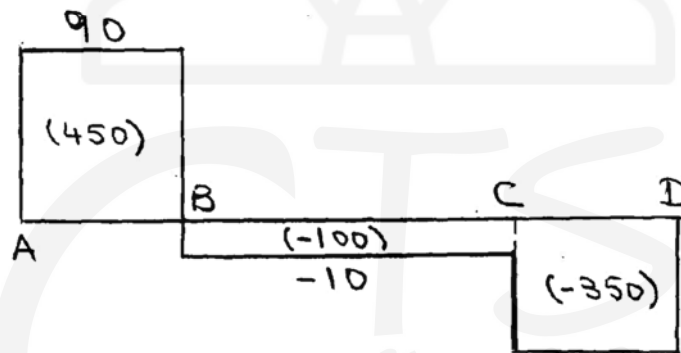
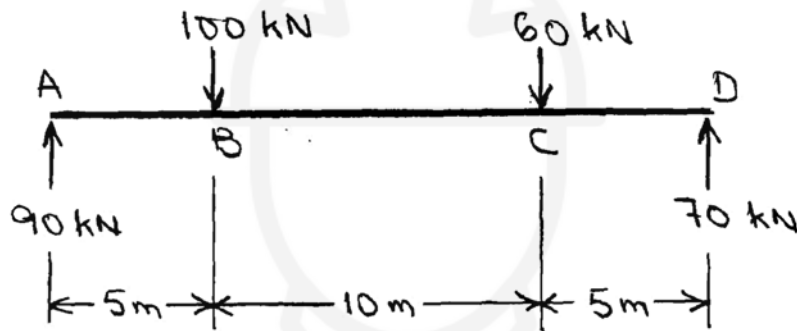

Example (2):

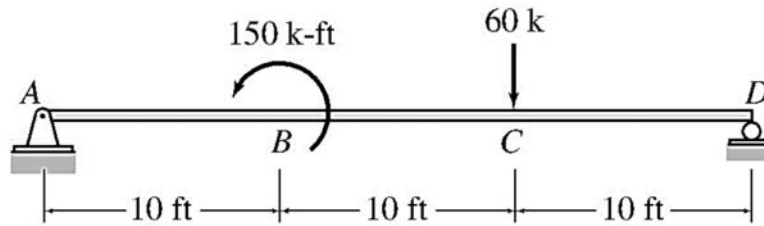

Solution:

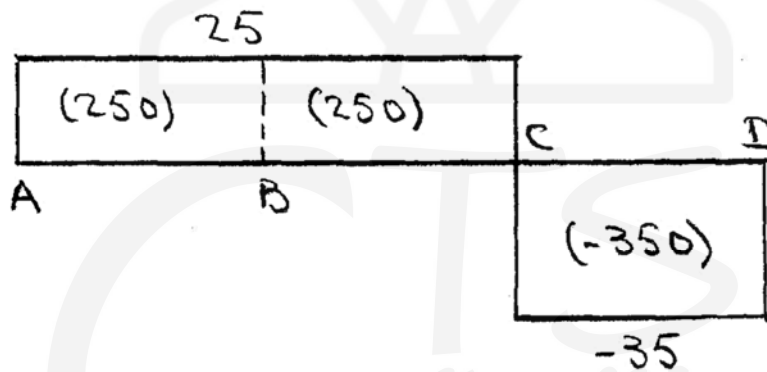
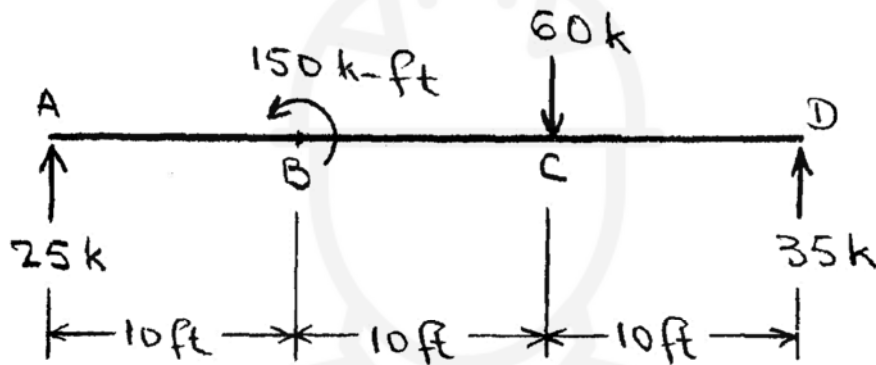

Shear Diagram (k)

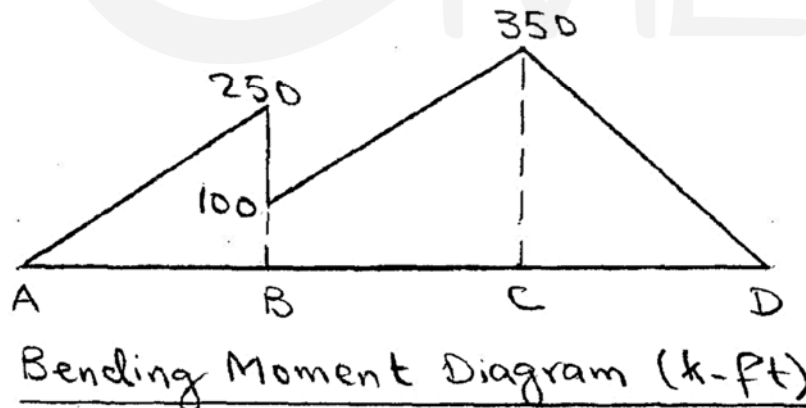

Bending Moment Diagram (k-ft)

Example (3):

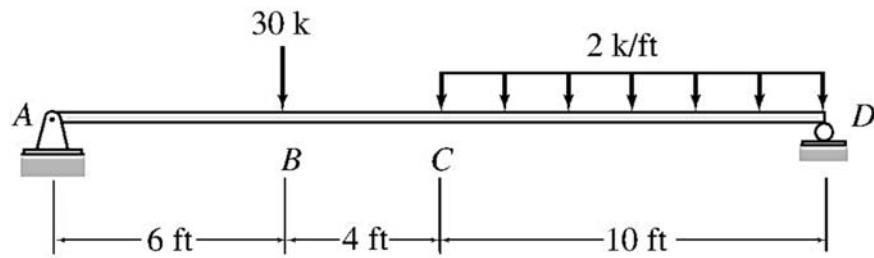

Solution:

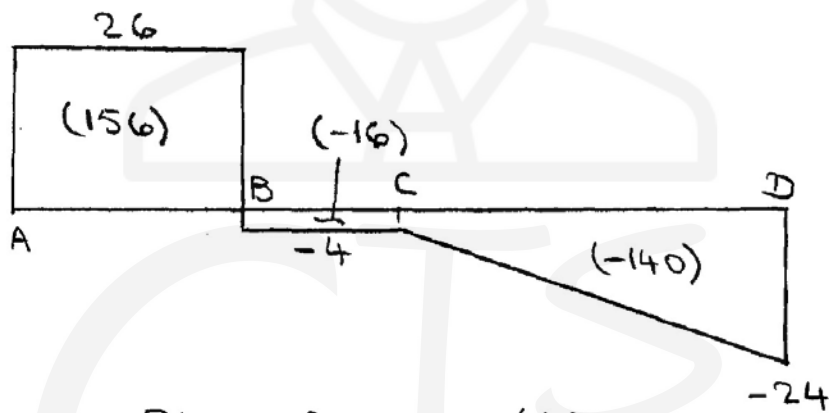
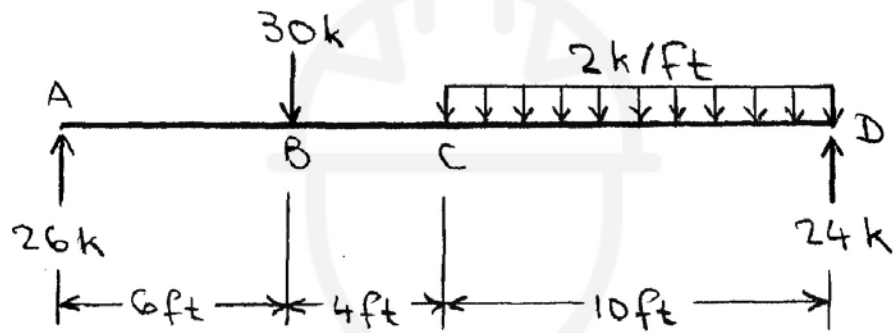

Shear Diagram (k)

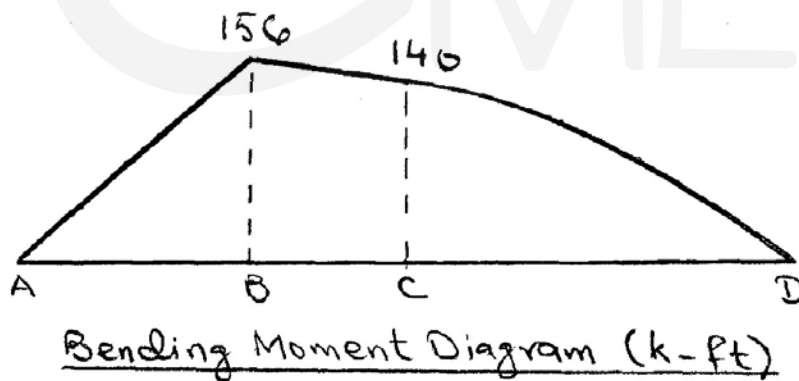

Bending Moment Diagram (k-ft)

Example (4):

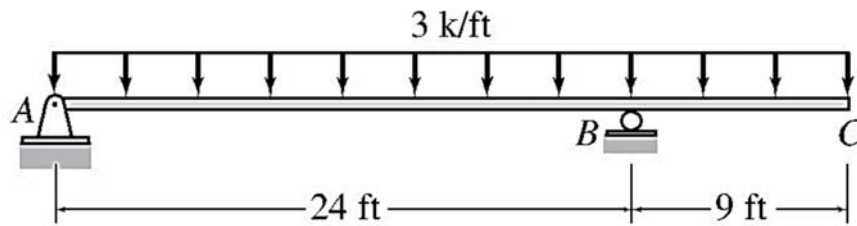

Solution:

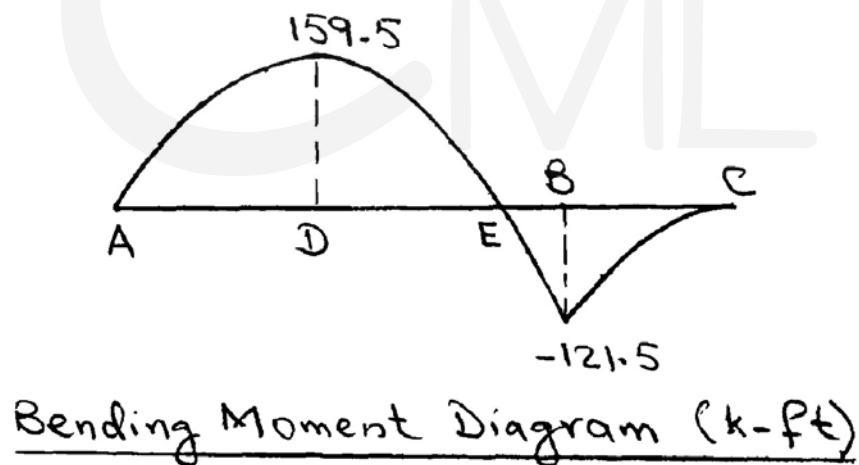
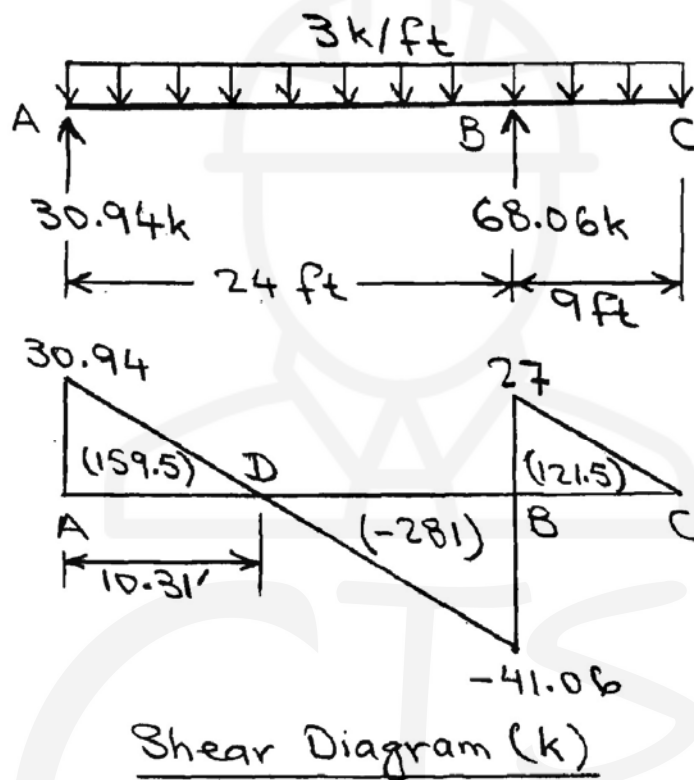

Example (5):

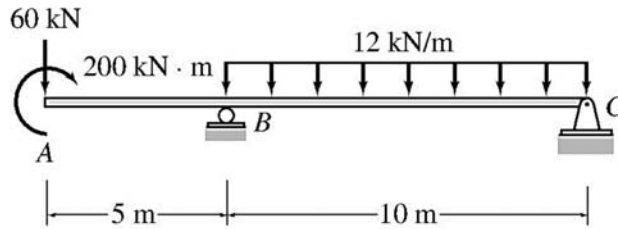

Solution:

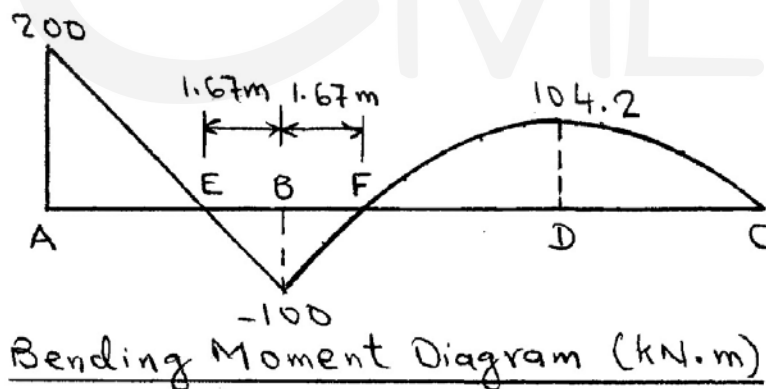
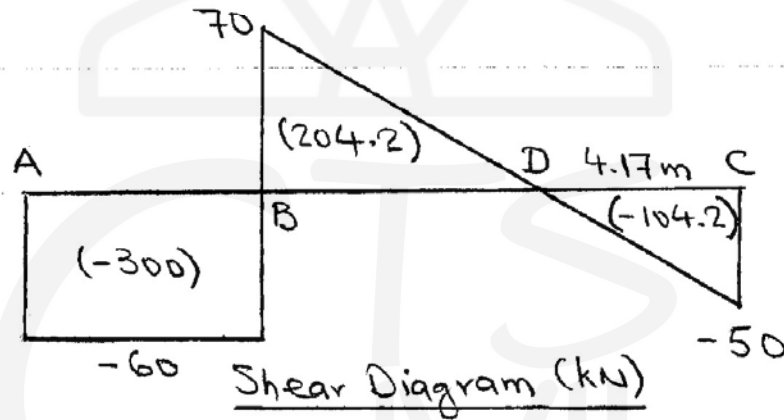
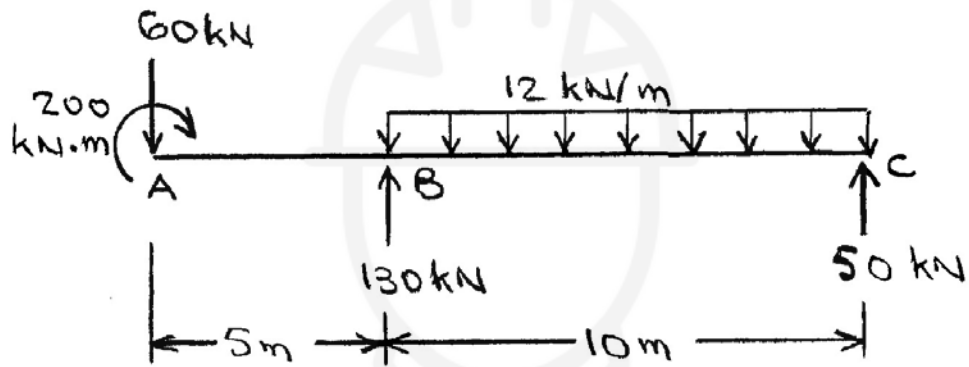

Example (6):

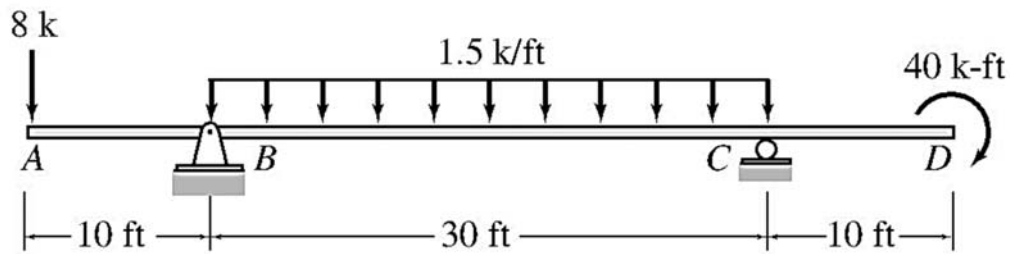

Solution:

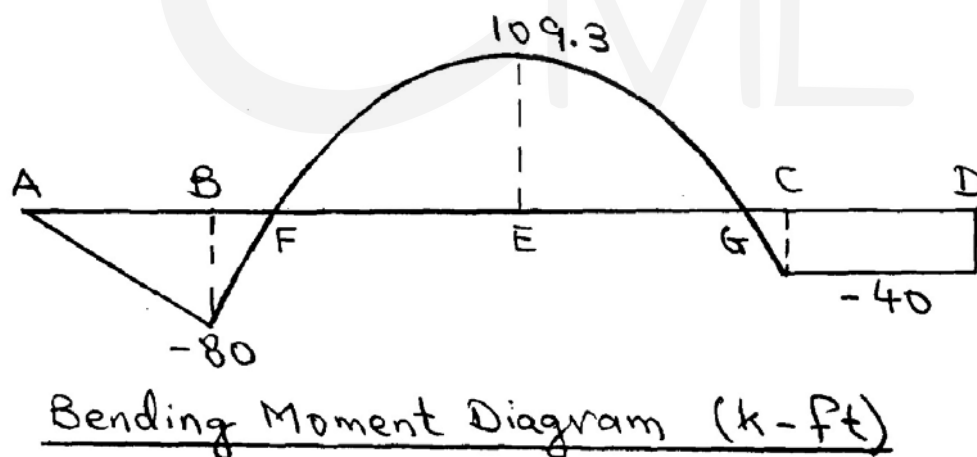
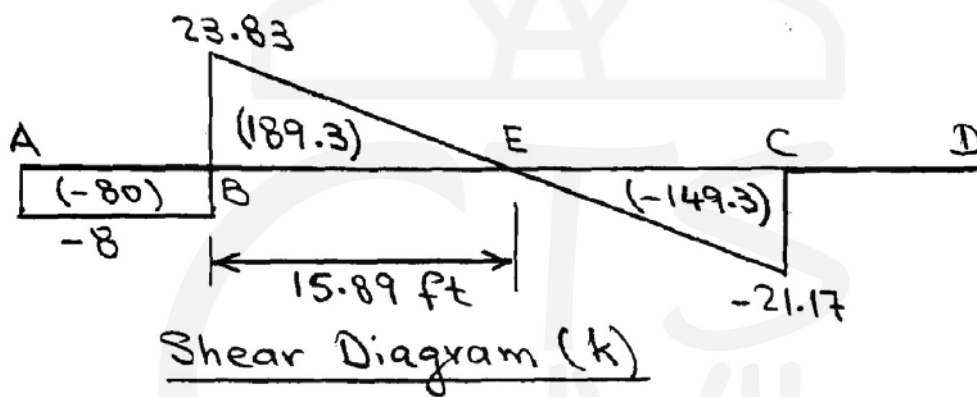
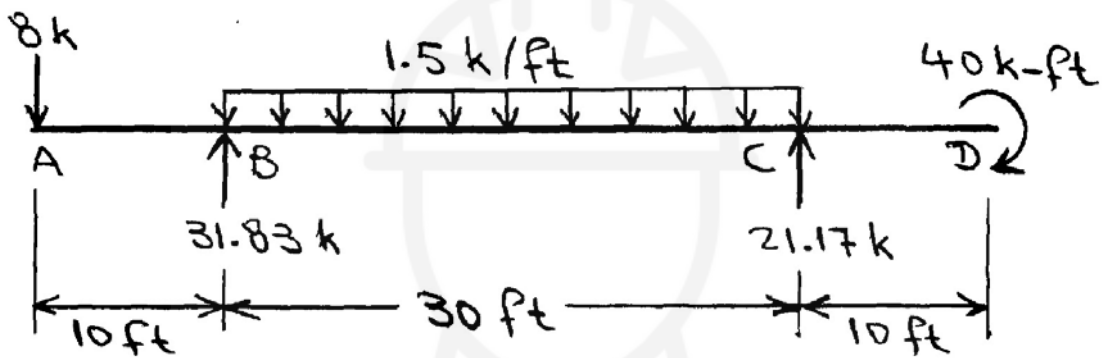

Example (7):

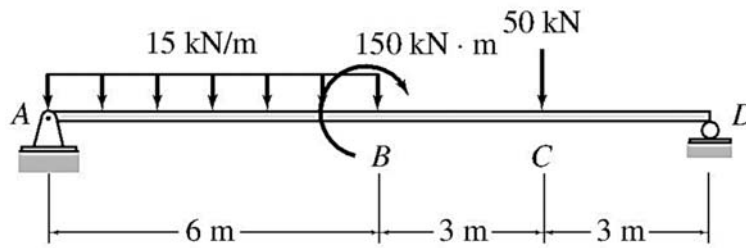

Solution:

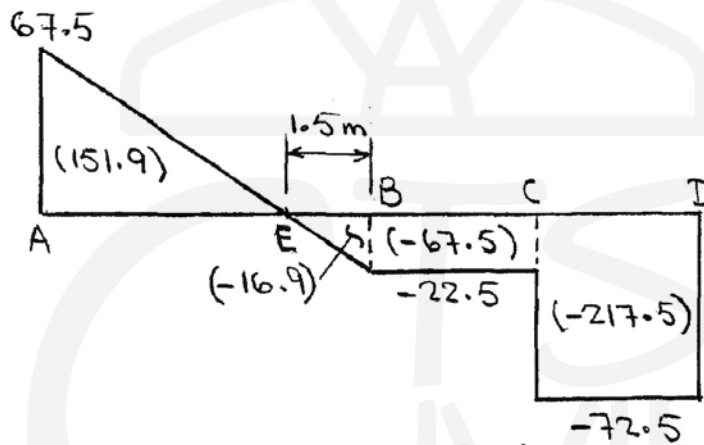
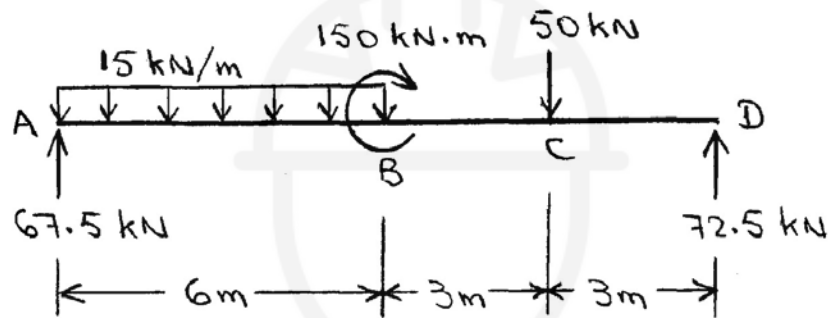

Shear Diagram (kN)

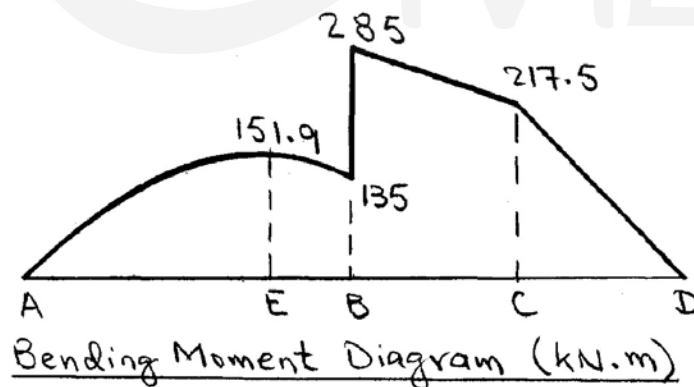

Bending Moment Diagram (kN.m)

2.10 Problems:

Question № 1:

For the beam shown in figure (1), What are the values of the shear force and bending moment at $x = \frac{l}{2}$?

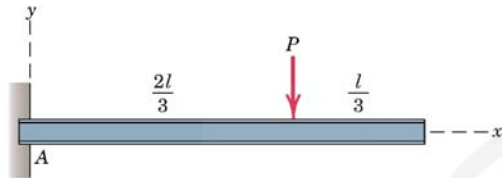

Figure 1

Question № 2:

For the beam shown in figure (2), determine the shear force V at a section B between A and C and the moment M at the support A .

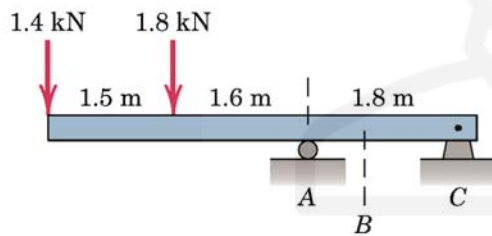

Figure 2

Question № 3:

Determine the shear V and bending moment M at a section of the loaded beam shown in figure (3) 200 mm to the right of A .

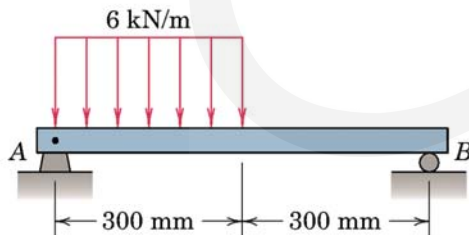

Figure 3

Question № 4:

Determine the shear V and bending moment M at a section of the loaded beam shown in figure (4) 2 m to the right of support A .

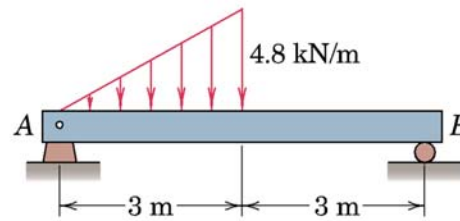

Figure 4

Question № 5:

For the beam shown in figure (5), find the shear force and bending moment at points C and D .

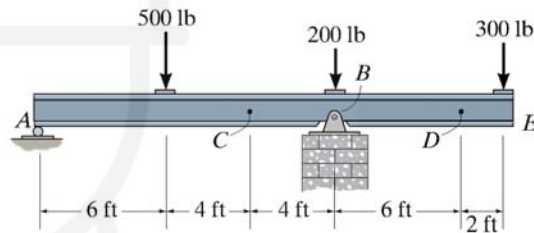

Figure 5

Question № 6:

For the beam shown in figure (6), find the shear force and bending moment at point C . Assume support A is a hinge and B is a roller.

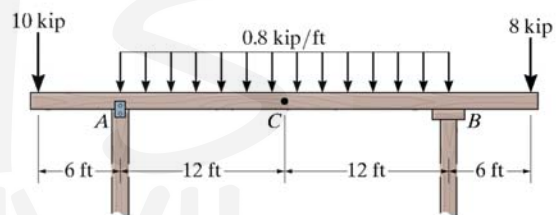

Figure 6

Question № 7:

For the beam shown in figure (7), What is the shear force and bending moment at a distance $(\frac{L}{2})$ from the left support? Assume support A is a hinge and B is a roller.

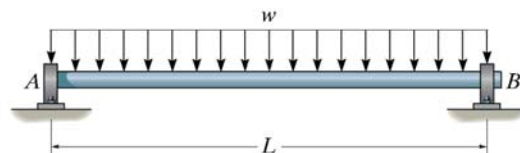

Figure 7

Question № 8:

For the beam shown in figure (8):

- Draw the shear force and bending moment diagrams.
- What are the values of the shear force and bending moment at points *C* and *D*.

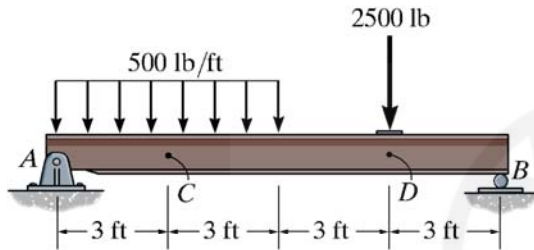

Figure 8

Question № 10:

For the beam shown in figure (10):

- Draw the shear force and bending moment diagrams.
- At what distance from support *A* the moment is zero?

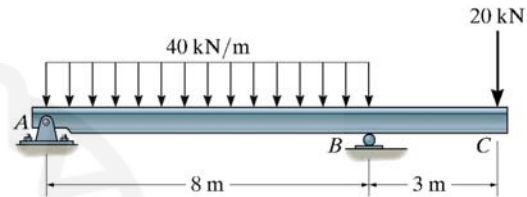

Figure 10

Question № 9:

For the beam shown in figure (9), draw the shear force and bending moment diagram. Assume support *A* is a hinge and *B* is a roller.

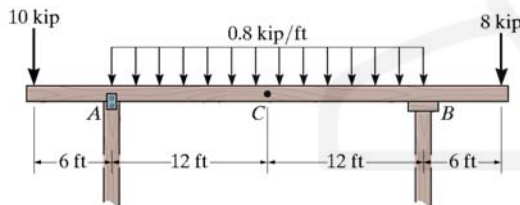

Figure 9

Question № 11:

Draw the shear force and bending moment diagram for the cantilever beam shown in figure (11).

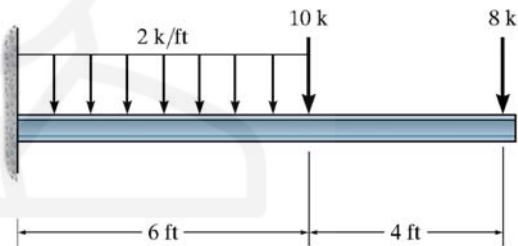

Figure 11

Chapter (3): Truss Analysis

3.1 Introduction:

Truss is an assemblage of straight members connected at their ends by flexible connections to form a rigid configuration. Because of their light weight and high strength, trusses are widely used, and their applications range from supporting bridges and roofs of buildings to being support structures in space stations. Modern trusses are constructed by connecting members, which usually consist of structural steel or aluminum shapes or wood struts, to gusset plates by bolted or welded connections.

If all the members of a truss and the applied loads lie in a single plane, the truss is called a plane truss. Plane trusses are commonly used for supporting decks of bridges and roofs of buildings.

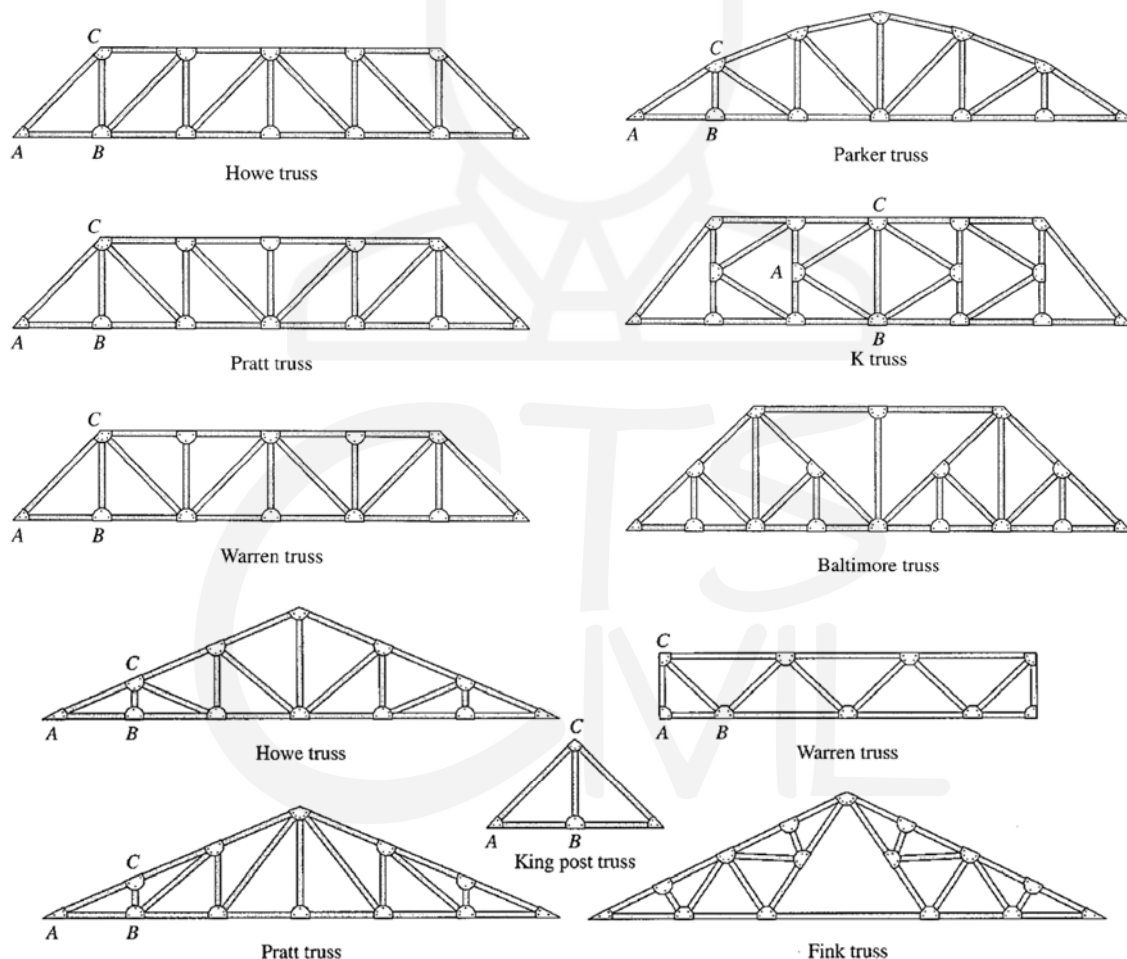

Figure 3-1: Common roof trusses

3.2 Assumptions for Analysis of Trusses:

The analysis of trusses is usually based on the following simplifying assumptions:

- 1- All members are connected only at their ends by frictionless hinges in plane trusses and by frictionless ball-and-socket joints in space trusses.
- 2- All loads and support reactions are applied only at the joints.
- 3- The centroidal axis of each member coincides with the line connecting the centers of the adjacent joints.

3.3 Method of Joints:

3.3.1 Procedure for Analysis

The following step-by-step procedure can be used for the analysis of statically determinate simple plane trusses by the method of joints.

- 1- Check the truss for static determinacy. If the truss is found to be statically determinate and stable, proceed to step 2. Otherwise, end the analysis at this stage.
- 2- Determine the slopes of the inclined members (except the zero-force members) of the truss.
- 3- Draw a free-body diagram of the whole truss, showing all external loads and reactions.
- 4- Examine the free-body diagram of the truss to select a joint that has no more than **two unknown** forces (which must not be collinear) acting on it. If such a joint is found, then go directly to the next step. Otherwise, determine reactions by applying the three equations of equilibrium and the equations of condition (if any) to the free body of the whole truss; then select a joint with two or fewer unknowns, and go to the next step.
- 5- a. Draw a free-body diagram of the selected joint, showing tensile forces by arrows pulling away from the joint and compressive forces by arrows pushing into the joint. It is usually convenient to assume the unknown member forces to be tensile.
b. Determine the unknown forces by applying the two equilibrium equations (x and y direction). A positive answer for a member force means that the member is in tension, as initially assumed, whereas a negative answer indicates that the member is in compression.

If at least one of the unknown forces acting at the selected joint is in the horizontal or vertical direction, the unknowns can be conveniently determined by satisfying the two equilibrium equations by inspection of the joint on the free-body diagram of the truss.

- 6- If all the desired member forces and reactions have been determined, then go to the next step. Otherwise, select another joint with no more than two unknowns, and return to step 5.

- 7- If the reactions were determined in step 4 by using the equations of equilibrium and condition of the whole truss, then apply the remaining joint equilibrium equations that have not been utilized so far to check the calculations. If the reactions were computed by applying the joint equilibrium equations, then use the equilibrium equations of the entire truss to check the calculations. If the analysis has been performed correctly, then these extra equilibrium equations must be satisfied.

For the following examples, find the forces in the members of the truss and indicate if the member is in tension or compression.



3.3.2 Examples:

Example (1):

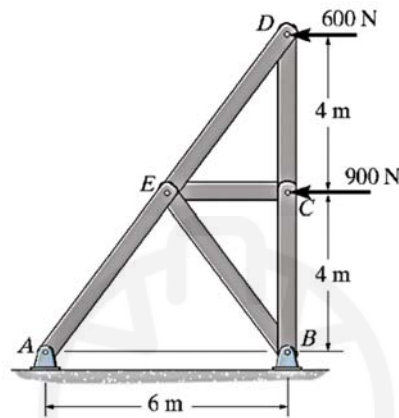

Solution:

Method of Joints: We will begin by analyzing the equilibrium of joint D , and then proceed to analyze joints C and E .

Joint D : From the free-body diagram in Fig. a ,

$$\begin{aligned} \rightarrow \Sigma F_x = 0; \quad & F_{DE} \left(\frac{3}{5} \right) - 600 = 0 \\ & F_{DE} = 1000 \text{ N} = 1.00 \text{ kN (C)} \end{aligned} \quad \text{Ans.}$$

$$\begin{aligned} + \uparrow \Sigma F_y = 0; \quad & 1000 \left(\frac{4}{5} \right) - F_{DC} = 0 \\ & F_{DC} = 800 \text{ N (T)} \end{aligned} \quad \text{Ans.}$$

Joint C : From the free-body diagram in Fig. b ,

$$\begin{aligned} \rightarrow \Sigma F_x = 0; \quad & F_{CE} - 900 = 0 \\ & F_{CE} = 900 \text{ N (C)} \end{aligned} \quad \text{Ans.}$$

$$\begin{aligned} + \uparrow \Sigma F_y = 0; \quad & 800 - F_{CB} = 0 \\ & F_{CB} = 800 \text{ N (T)} \end{aligned} \quad \text{Ans.}$$

Joint E : From the free-body diagram in Fig. c ,

$$\begin{aligned} \searrow + \Sigma F_x' = 0; \quad & -900 \cos 36.87^\circ + F_{EB} \sin 73.74^\circ = 0 \\ & F_{EB} = 750 \text{ N (T)} \end{aligned} \quad \text{Ans.}$$

$$\begin{aligned} \nearrow + \Sigma F_y' = 0; \quad & F_{EA} - 1000 - 900 \sin 36.87^\circ - 750 \cos 73.74^\circ = 0 \\ & F_{EA} = 1750 \text{ N} = 1.75 \text{ kN (C)} \end{aligned} \quad \text{Ans.}$$

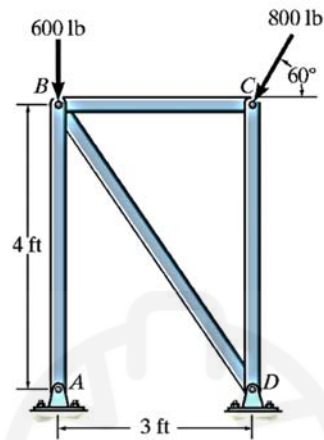
Example (2):**Solution:****Joint C:**

$$\pm \rightarrow \Sigma F_x = 0; \quad F_{CB} - 800 \cos 60^\circ = 0$$

$$F_{CB} = 400 \text{ lb (C)}$$

Ans.

$$+\uparrow \Sigma F_y = 0; \quad F_{CD} - 800 \sin 60^\circ = 0$$

$$F_{CD} = 693 \text{ lb (C)}$$

Ans.**Joint B:**

$$\pm \rightarrow \Sigma F_x = 0; \quad \frac{3}{5} F_{BD} - 400 = 0$$

$$F_{BD} = 666.7 = 667 \text{ lb (T)}$$

Ans.

$$+\uparrow \Sigma F_y = 0; \quad F_{BA} - \frac{4}{5} (666.7) - 600 = 0$$

$$F_{BA} = 1133 \text{ lb} = 1.13 \text{ kip (C)}$$

Ans.

Member AB is a two-force member and exerts only a vertical force along AB at A .

Example (3):

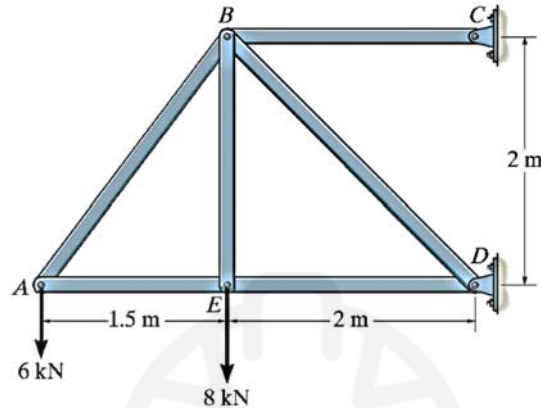

Solution:

Joint A:

$$+\uparrow \Sigma F_y = 0; \quad \frac{4}{5} F_{AB} - 6 = 0$$

$$F_{AB} = 7.5 \text{ kN (T)}$$

Ans.

$$\pm \Sigma F_x = 0; \quad -F_{AE} + 7.5 \left(\frac{3}{5} \right) = 0$$

$$F_{AE} = 4.5 \text{ kN (C)}$$

Ans.

Joint E:

$$\pm \Sigma F_x = 0; \quad F_{ED} = 4.5 \text{ kN (C)}$$

Ans.

$$+\uparrow \Sigma F_y = 0; \quad F_{EB} = 8 \text{ kN (T)}$$

Ans.

Joint B:

$$+\uparrow \Sigma F_y = 0; \quad \frac{1}{\sqrt{2}} (F_{BD}) - 8 - \frac{4}{5} (7.5) = 0$$

$$F_{BD} = 19.8 \text{ kN (C)}$$

Ans.

$$\pm \Sigma F_x = 0; \quad F_{BC} - \frac{3}{5} (7.5) - \frac{1}{\sqrt{2}} (19.8) = 0$$

$$F_{BC} = 18.5 \text{ kN (T)}$$

Ans.

C_y is zero because BC is a two-force member .

Example (4):

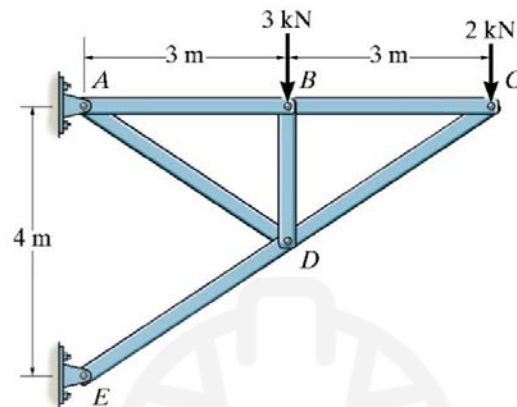

Solution:

Joint C:

$$+\uparrow \Sigma F_y = 0; \quad \frac{2}{\sqrt{13}} F_{CD} - 2 = 0$$

$$F_{CD} = 3.606 = 3.61 \text{ kN (C)}$$

Ans.

$$\pm \Sigma F_x = 0; \quad -F_{CD} + 3.606 \left(\frac{3}{\sqrt{13}} \right) = 0$$

$$F_{CB} = 3 \text{ kN (T)}$$

Ans.

Joint B:

$$\pm \Sigma F_x = 0; \quad F_{BA} = 3 \text{ kN (T)}$$

Ans.

$$+\uparrow \Sigma F_y = 0; \quad F_{BD} = 3 \text{ kN (C)}$$

Ans.

Joint D:

$$\pm \Sigma F_x = 0; \quad \frac{3}{\sqrt{13}} F_{DE} - \frac{3}{\sqrt{13}} (3.606) + \frac{3}{\sqrt{13}} F_{DA} = 0$$

$$+\uparrow \Sigma F_y = 0; \quad \frac{2}{\sqrt{13}} (F_{DE}) - \frac{2}{\sqrt{13}} (F_{DA}) - \frac{2}{\sqrt{13}} (3.606) - 3 = 0$$

$$F_{DA} = 2.70 \text{ kN (T)}$$

Ans.

$$F_{DE} = 6.31 \text{ kN (C)}$$

Ans.

3.4 Problems:

Determine the force in each member of the trusses shown in the figures below and indicate if the members are in tension or compression. Summarize your answers in a table format showing member's name, force value, and force type.

Question № 1:

Let $P_1 = 800$ lb and $P_2 = 400$ lb.

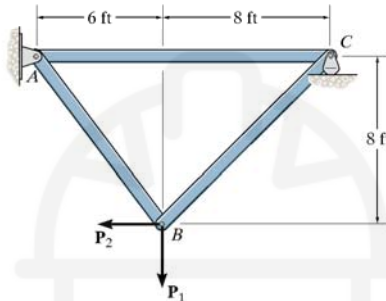

Figure 1

Question № 2:

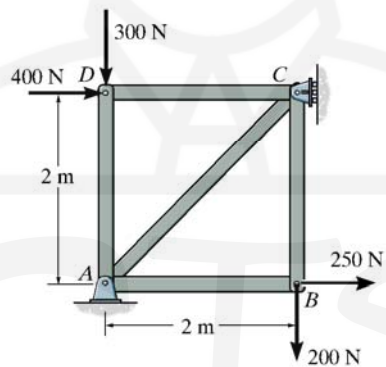

Figure 2

Question № 3:

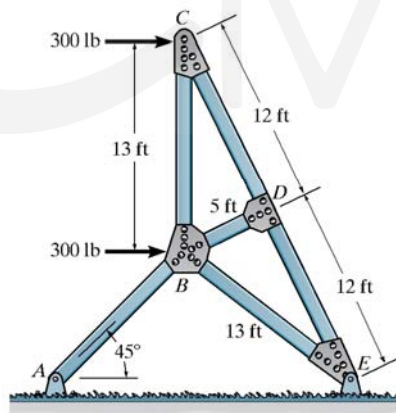

Figure 3

Question № 4:

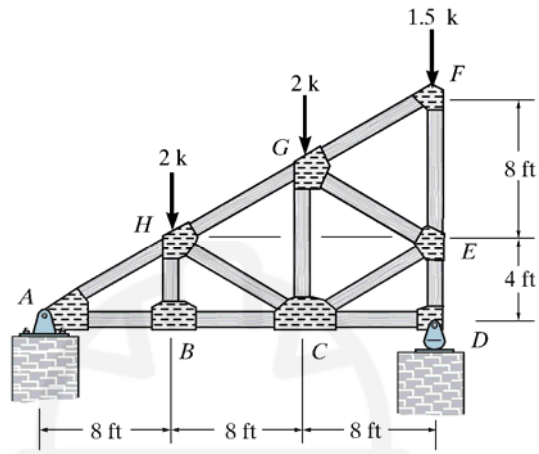

Figure 4

Question № 5:

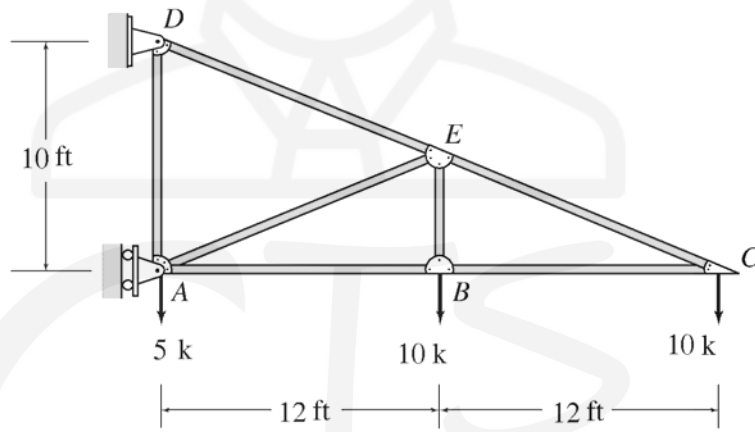

Figure 5

Question № 6:

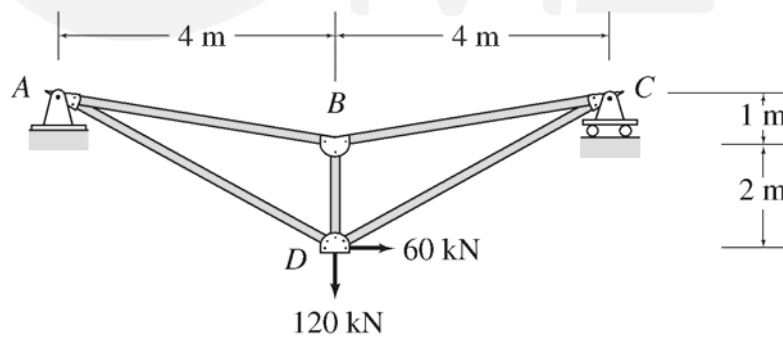

Figure 6

Question № 7:

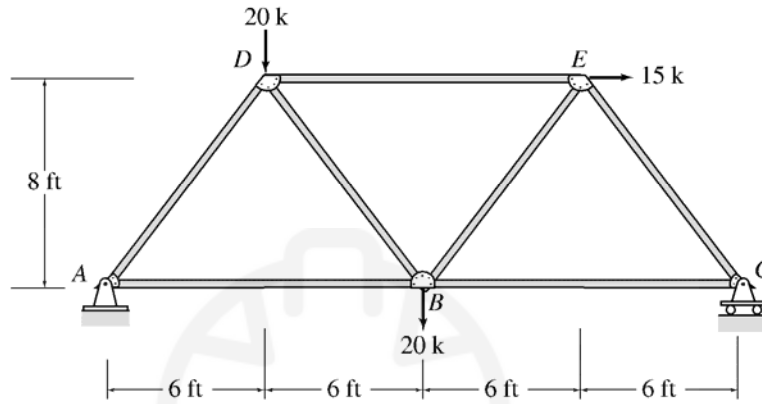

Figure 7

3.5 Method of Sections:

3.5.1 Procedure for Analysis:

The following step-by-step procedure can be used for determining the member forces of statically determinate plane trusses by the method of sections.

1. Select a section that passes through as many members as possible whose forces are desired, but not more than three members with unknown forces. The section should cut the truss into two parts.
2. Although either of the two portions of the truss can be used for computing the member forces, we should select the portion that will require the least amount of computational effort in determining the unknown forces. To avoid the necessity for the calculation of reactions, if one of the two portions of the truss does not have any reactions acting on it, then select this portion for the analysis of member forces and go to the next step. If both portions of the truss are attached to external supports, then calculate reactions by applying the equations of equilibrium and condition (if any) to the free body of the entire truss. Next, select the portion of the truss for analysis of member forces that has the least number of external loads and reactions applied to it.
3. Draw the free-body diagram of the portion of the truss selected, showing all external loads and reactions applied to it and the forces in the members that have been cut by the section. The unknown member forces are usually assumed to be tensile and are, therefore, shown on the free-body diagram by arrows pulling away from the joints.
4. Determine the unknown forces by applying the three equations of equilibrium. To avoid solving simultaneous equations, try to apply the equilibrium equations in such a manner that each equation involves only one unknown. This can sometimes be achieved by using the alternative systems of equilibrium equations (Sum of moment equations) instead of the usual two-force summations and a moment summation system of equations.
5. Apply an alternative equilibrium equation, which was not used to compute member forces, to check the calculations. This alternative equation should preferably involve all three-member forces determined by the analysis. If the analysis has been performed correctly, then this alternative equilibrium equation must be satisfied.

For the following examples, use the method of sections to solve for the required members (indicated by x) and state whether the members are in tension or compression.

3.5.2 Examples:

Example (1):

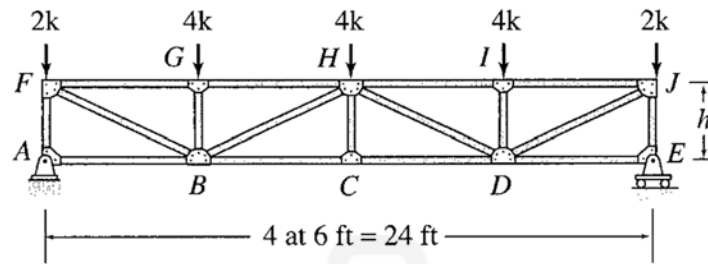

Solution:

Section through members BC, BH and GH:

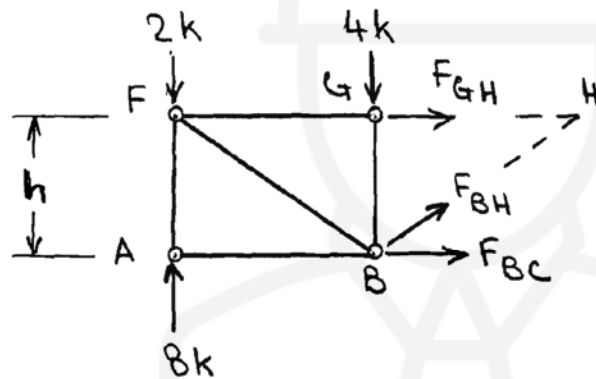

$$+\circlearrowleft \sum M_B = 0 \quad -8(6) + 2(6) - F_{GH}(h) = 0$$

$$F_{GH} = -\frac{36}{h} \quad (1)$$

$$+\circlearrowleft \sum M_H = 0 \quad -8(12) + 2(12) + 4(6) + F_{BC}(h) = 0$$

$$F_{BC} = \frac{48}{h} \quad (2)$$

Equations (1) and (2) indicate that the magnitudes of F_{GH} and F_{BC} are inversely proportional to the truss height h .

For $h = 3$ ft:

$$F_{GH} = -\frac{36}{3} = -12k = \underline{12k (C)}$$

$$F_{BC} = \frac{48}{3} = \underline{16k (T)}$$

For $h = 6$ ft:

$$F_{GH} = -\frac{36}{6} = -6k = \underline{6k (C)}$$

$$F_{BC} = \frac{48}{6} = \underline{8k (T)}$$

Example (2):

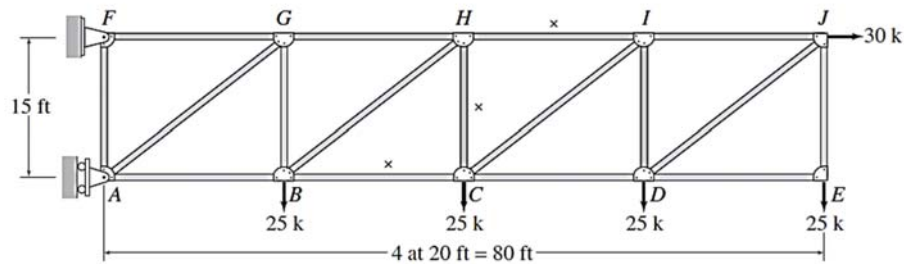

Solution:

Section through members BC, CH and HI:

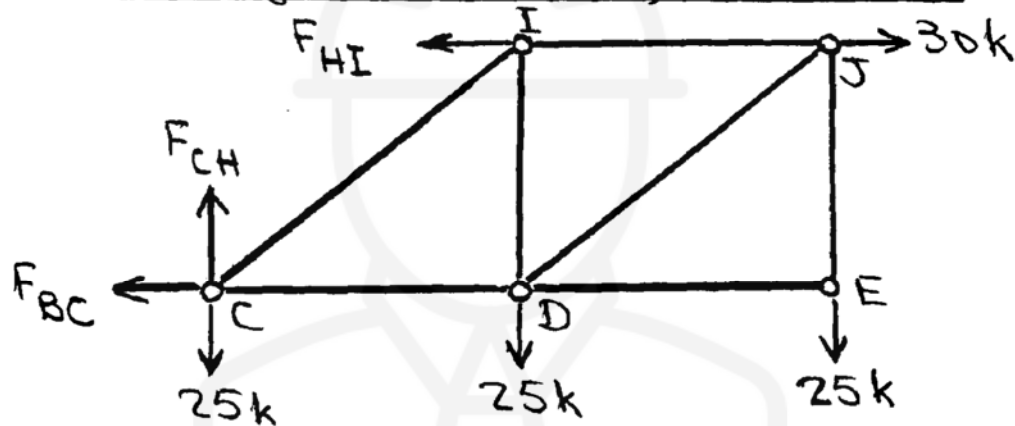

$$+\uparrow \Sigma F_y = 0 \quad F_{CH} - 3(25) = 0$$

$$F_{CH} = 75 \text{ k (T)}$$

$$+\curvearrowright \Sigma M_C = 0$$

$$F_{HI}(15) - 30(15) - 25(20) - 25(40) = 0$$

$$F_{HI} = 130 \text{ k (T)}$$

$$\pm \rightarrow \Sigma F_x = 0$$

$$-F_{BC} - 130 + 30 = 0$$

$$F_{BC} = -100 \text{ k}$$

$$F_{BC} = 100 \text{ k (C)}$$

Example (3):

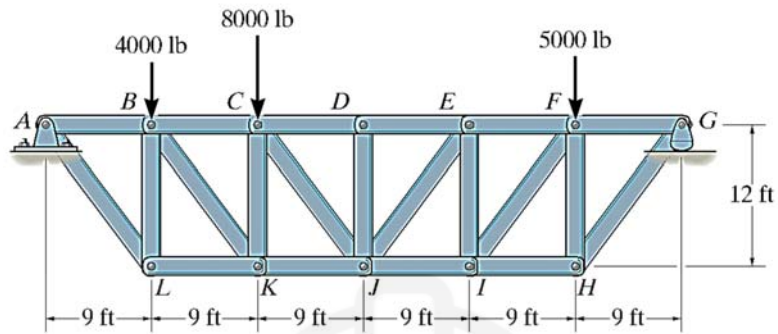

Members: EI, JI

Solution:

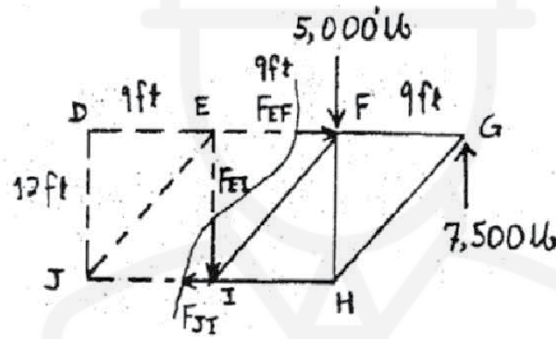

$$\zeta + \Sigma M_E = 0; \quad -5000(9) + 7500(18) - F_{JI}(12) = 0$$

$$F_{JI} = 7500 \text{ lb} = 7.50 \text{ kip (T)}$$

Ans.

$$+ \uparrow \Sigma F_y = 0; \quad 7500 - 5000 - F_{EI} = 0$$

$$F_{EI} = 2500 \text{ lb} = 2.50 \text{ kip (C)}$$

Ans.

Example (4):

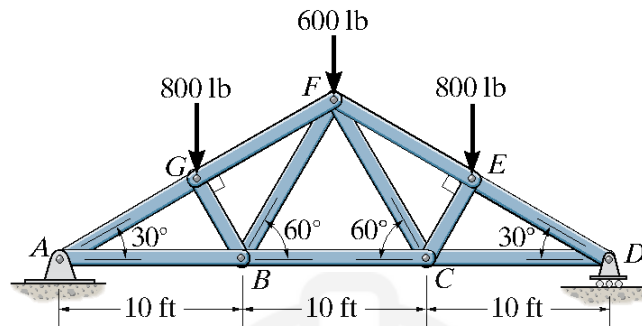

Members: FE, EC

Solution:

Support Reactions: Due to symmetry,

$$+\uparrow \Sigma F_y = 0; \quad 2B_y - 800 - 600 - 800 = 0; B_y = 1100 \text{ lb}$$

Method of Sections:

$$\zeta + \Sigma M_C = 0; \quad 1100(10) - 800(10 - 7.5) - (F_{FE} \sin 30^\circ)(10) = 0$$

$$F_{FE} = 1.80 \text{ kip (C)}$$

Ans.

Joint E:

$$+\uparrow \Sigma F_y = 0; \quad F_{EC} - 800 \cos 30^\circ = 0$$

$$F_{EC} = 693 \text{ lb (C)}$$

Ans.

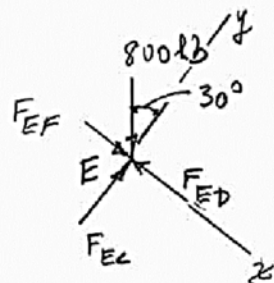
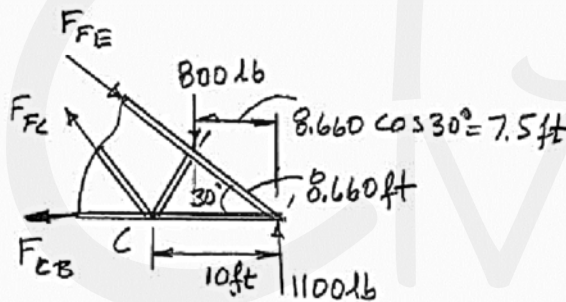

3.6 Problems:

Determine the forces in the members identified by "x" of the trusses shown by the method of sections. Indicate if the members are in tension or compression. Summarize your answers in a table format showing member's name, force value, and force type.

Question № 1:

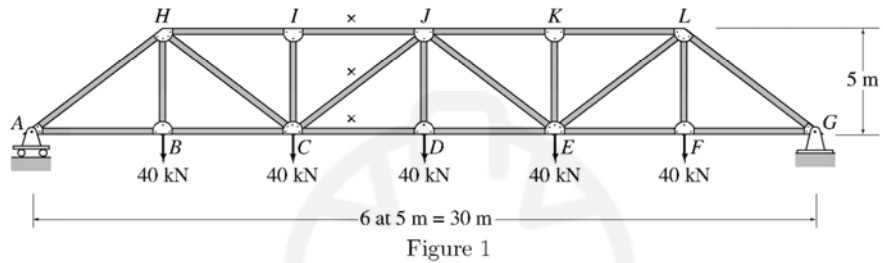

Question № 2:

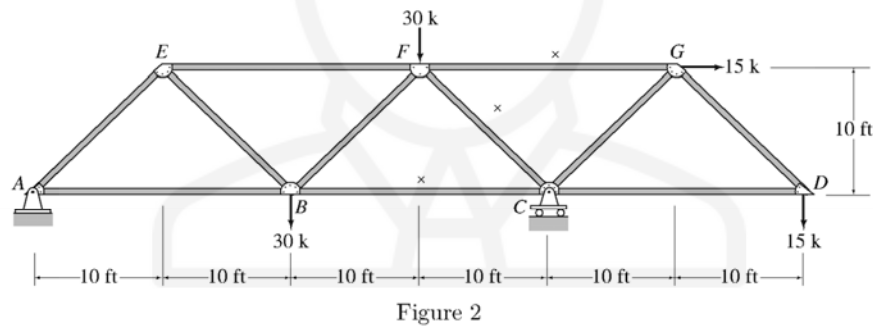

Question № 3:

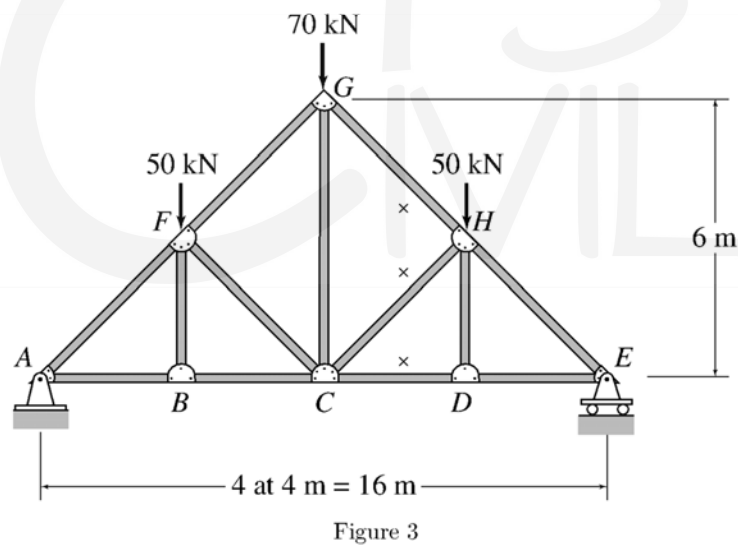

Question № 4:

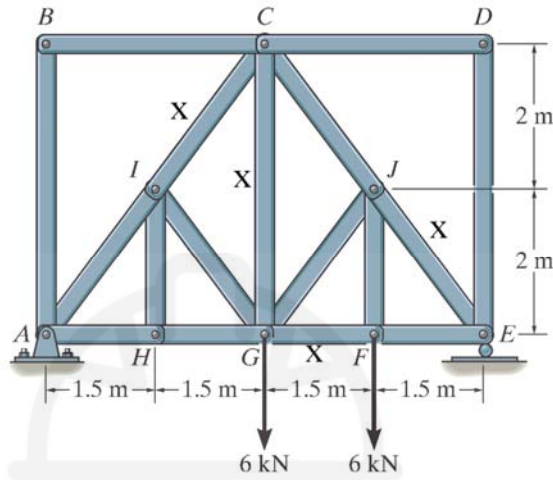

Figure 4

Question № 5:

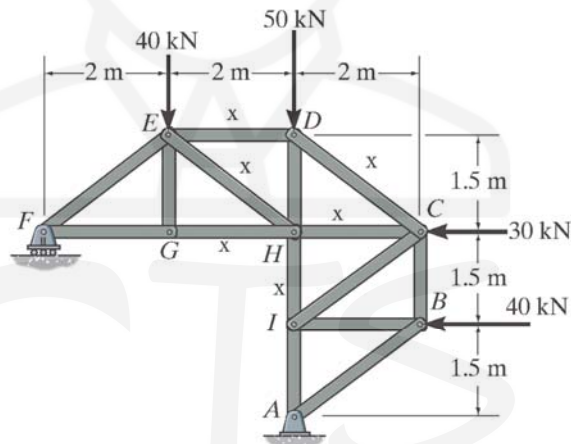

Figure 5

Question № 6:

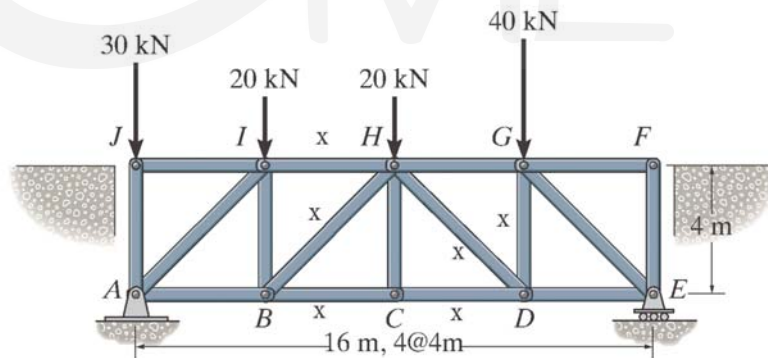

Figure 6

Chapter (4): Frame Analysis

4.1 Types of Frame Structures:

Frame structures are the structures having the combination of beam, column and slab to resist the lateral and gravity loads. These structures are usually used to overcome the large moments developing due to the applied loading. Frames structures can be differentiated into:

- 1- Rigid frame structure: which are further subdivided into:
 - a. Pin ended
 - b. Fixed ended
- 2- Braced frame structure: which is further subdivided into:
 - a. Gabled frames
 - b. Portal frames

4.1.1 Rigid Structural Frame

The word rigid means ability to resist the deformation. Rigid frame structures can be defined as the structures in which beams & columns are made monolithically and act collectively to resist the moments which are generating due to applied load. Rigid frame structure provides more stability. This type of frame structures resists the shear, moment and torsion more effectively than any other type of frame structures. That's why this frame system is used in world's most astonishing building Burj Al-Arab.



Figure 4-1: Braced Structural Frame

Pin Ended Rigid Structural Frames:

A pinned ended rigid frame system usually has pins as their support conditions. This frame system is considered to be non-rigid if its support conditions are removed.

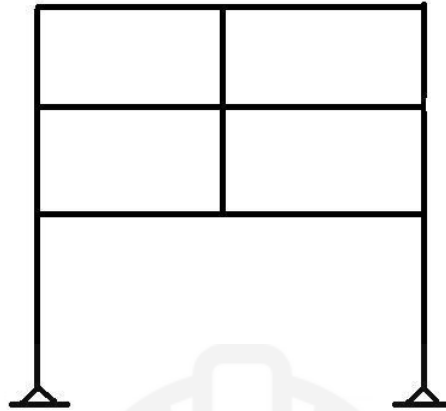

Figure 4-2: Pin Ended Rigid Structural Frame

Fix Ended Rigid Frame Structure:

In this type of rigid frame systems end conditions are usually fixed.

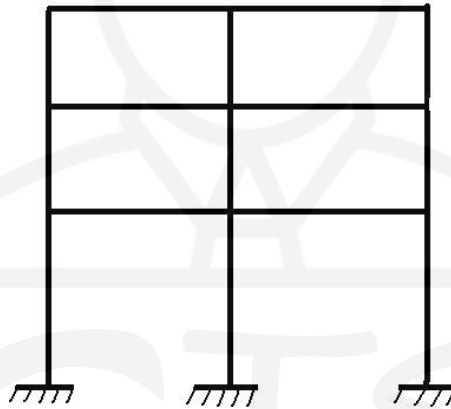

Figure 4-3: Fixed Ended Rigid Structural Frame

4.1.2 Braced Structural Frames

In this frame system (Figure 4-4), bracing is usually provided between beams and columns to increase their resistance against the lateral forces and side-ways forces due to applied load. Bracing is usually done by placing the diagonal members between the beams and columns. This frame system provides more efficient resistance against the earthquake and wind forces. This frame system is more effective than rigid frame system.

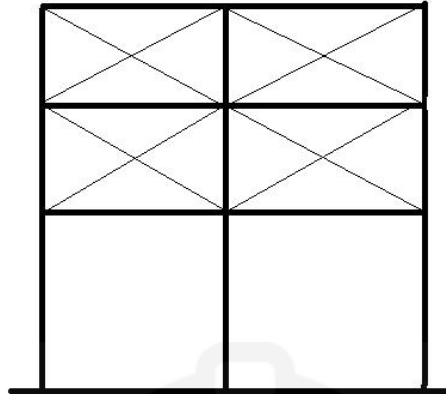

Figure 4-4: Braced Structural Frame

Gabled Structural Frame:

Gable frame steel structure building is a typical construction system. Its upper structure consists of steel of parapet, gutter, roof purlin, steel frame, and wall purlin, etc. This kind of building offers a series of advantages and features.

- 1- This product is lightweight and its steel volume of bearing structure is in the range of 20 kg to 50kg per square meter. Its dead weight ranges from 1/20 to 1/3 of reinforced concrete structure. Therefore, this structure greatly reduces damages from earthquake and lessens its foundation costs.
- 2- It comes with short construction period and high economic benefits.
- 3- The arrangement of columns is quite flexible.

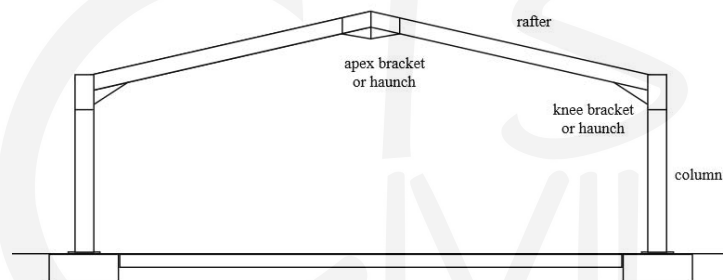

Figure 4-5: Gabled Structural Frame

Portal Structural Frame:

Portal structural frames usually look like a door. This frame system is very much in use for construction of industrial and commercial buildings

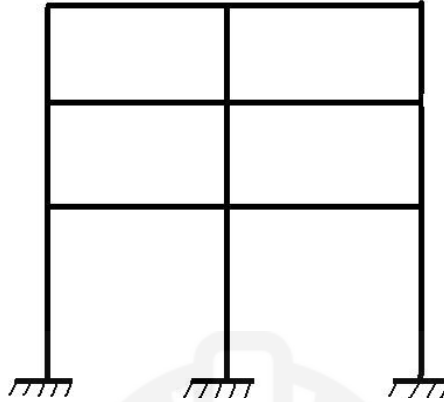

Figure 4-6: Portal Structural Frame

4.1.3 Load path in Frame Structure:

It is a path through which the load of a frame structure is transmitted to the foundations. In frame structures, usually load first transfers from slab to beams then to from beam to columns, then from columns it transfers to the foundation.

Advantages of Frame Structures

One of the best advantages of frame structures is their ease in construction. it is very east to teach the labor at the construction site.

Frame structures can be constructed rapidly.

Economy is also very important factor in the design of building systems. Frame structures have economical designs.

Disadvantages of Frames:

In frames structures, span lengths are usually restricted to 40 ft when normal reinforced concrete. Otherwise spans greater than that, can cause lateral deflections.

4.1.4 Comparison of Frame structures with Normal Load bearing Traditional High Rise Building:

Selection of frame structures for the high rise building is due to their versatility and advantages over the normal traditional load bearing structures. These include the following:

- 1- Actually the performance of load bearing structures is usually dependent on the mass of structures. To fulfill this requirement of load bearing structures, there is the need of increase in volume of structural elements (walls, slab).this increase in volume of the structural elements leads toward the construction of thick wall. Due to such a type of construction, labor and construction cost increases. in construction of thick wall there will be the need of great attention, which will further reduce the speed of construction.
- 2- If we make the contrast of load bearing structures with the framed structures, framed structures appear to be more flexible, economical and can carry the heavy

loads. Frame structures can be rehabilitated at any time. Different services can be provided in frame structures. Thus the frame structures are flexible in use.

4.1.5 Frame Reactions:

For the following examples, calculate the reactions at the frame supports.

4.1.6 Examples:

Example (1):

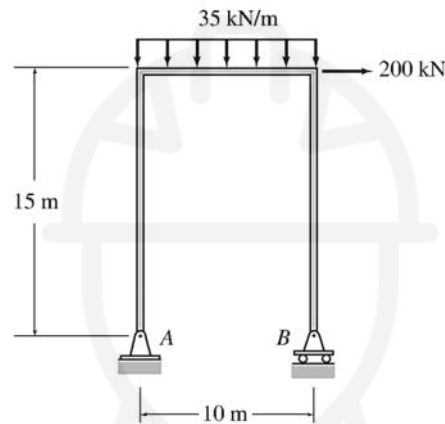

Solution:

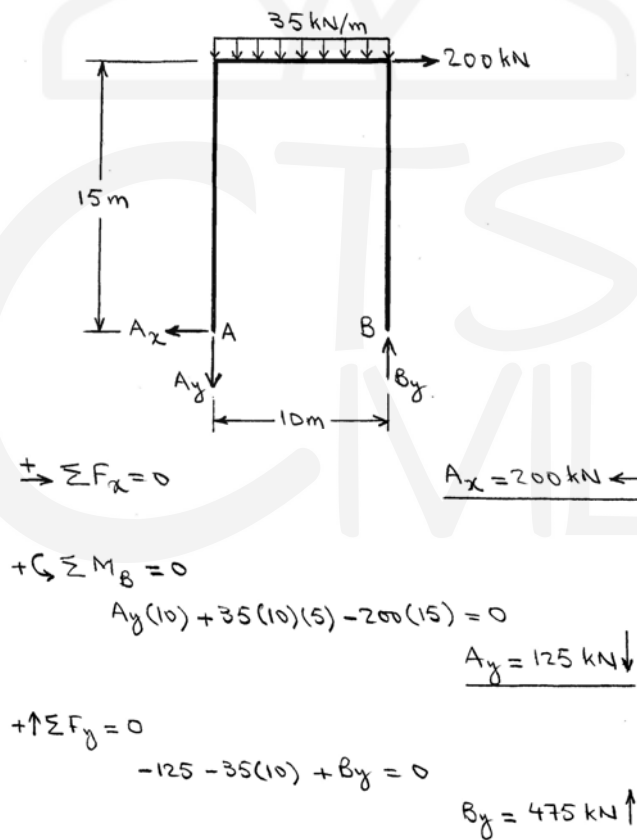

Example (2):

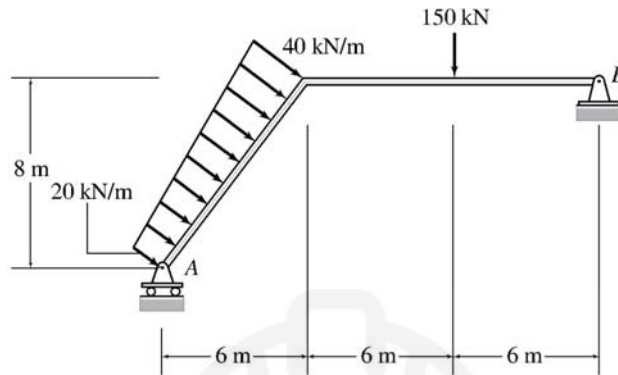

Solution:

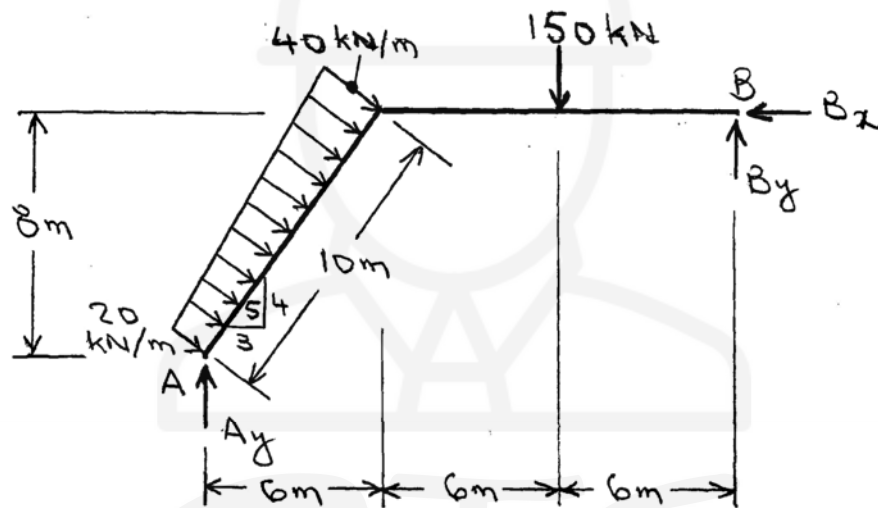

$$+\rightarrow \Sigma F_x = 0 \quad \left(\frac{20+40}{2} \right) 10 \left(\frac{4}{5} \right) - B_x = 0$$

$$\underline{B_x = 240 \text{ kN} \leftarrow}$$

$$+\curvearrowright \Sigma M_A = 0$$

$$-20(10)5 - \frac{1}{2}(20)10\left(\frac{20}{3}\right) - 150(12) + 240(8) + B_y(18) = 0$$

$$\underline{B_y = 85.93 \text{ kN} \uparrow}$$

$$+\uparrow \Sigma F_y = 0$$

$$A_y - \left(\frac{20+40}{2} \right) 10 \left(\frac{3}{5} \right) - 150 + 85.93 = 0$$

$$\underline{A_y = 244.07 \text{ kN} \uparrow}$$

Example (3):

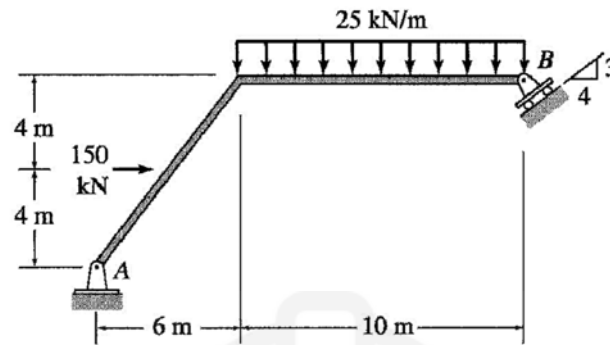

Solution:

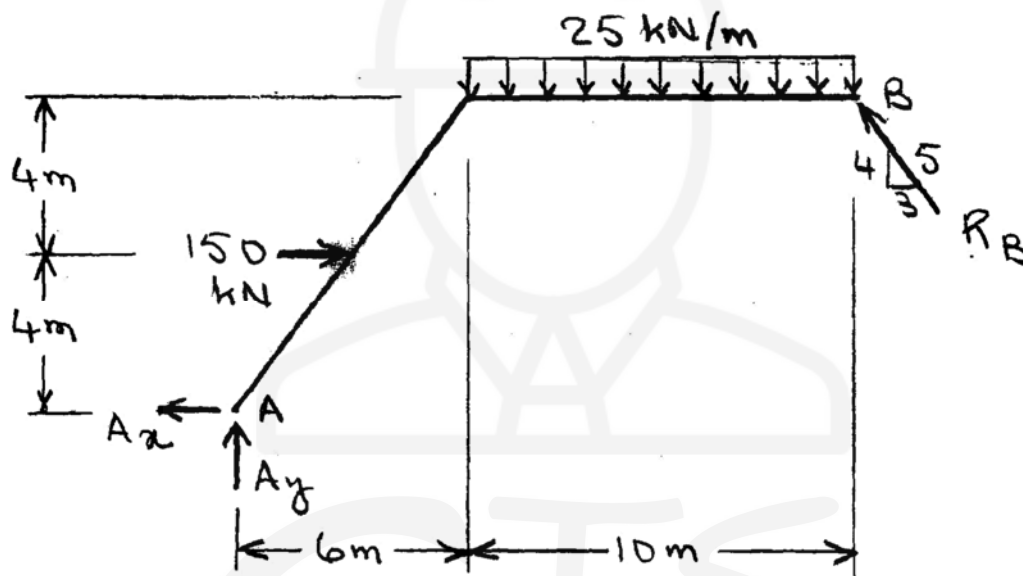

$$+\circlearrowleft \sum M_A = 0$$

$$-150(4) - 25(10)(11) + \frac{3}{5}R_B(8) + \frac{4}{5}R_B(16) = 0$$

$$\underline{R_B = 190.3 \text{ kN} \uparrow}$$

$$+\rightarrow \sum F_x = 0 \quad -A_x + 150 - \frac{3}{5}(190.3) = 0$$

$$\underline{A_x = 35.8 \text{ kN} \leftarrow}$$

$$+\uparrow \sum F_y = 0 \quad A_y - 25(10) + \frac{4}{5}(190.3) = 0$$

$$\underline{A_y = 97.7 \text{ kN} \uparrow}$$

Example (4):

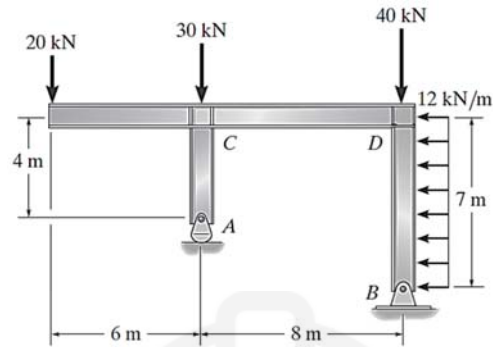

Solution:

$$\zeta + \sum M_B = 0; \quad 20(14) + 30(8) + 84(3.5) - A_y(8) = 0$$

$$A_y = 101.75 \text{ kN} = 102 \text{ kN}$$

$$\rightarrow \sum F_x = 0; \quad B_x - 84 = 0$$

$$B_x = 84.0 \text{ kN}$$

$$+\uparrow \sum F_y = 0; \quad 101.75 - 20 - 30 - 40 - B_y = 0$$

$$B_y = 11.8 \text{ kN}$$

4.2 Internal Forces in Frames:

4.2.1 Examples:

Example (1):

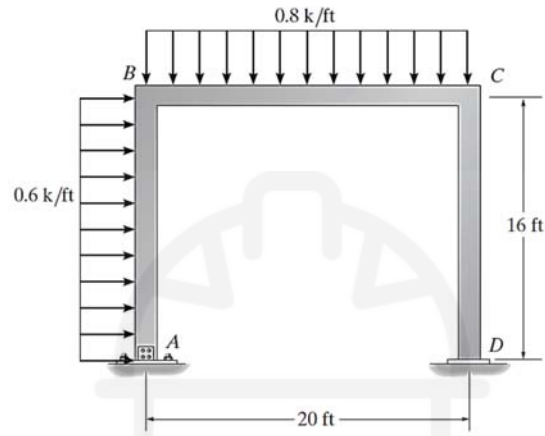

A → Pin, D → Roller

Solution:

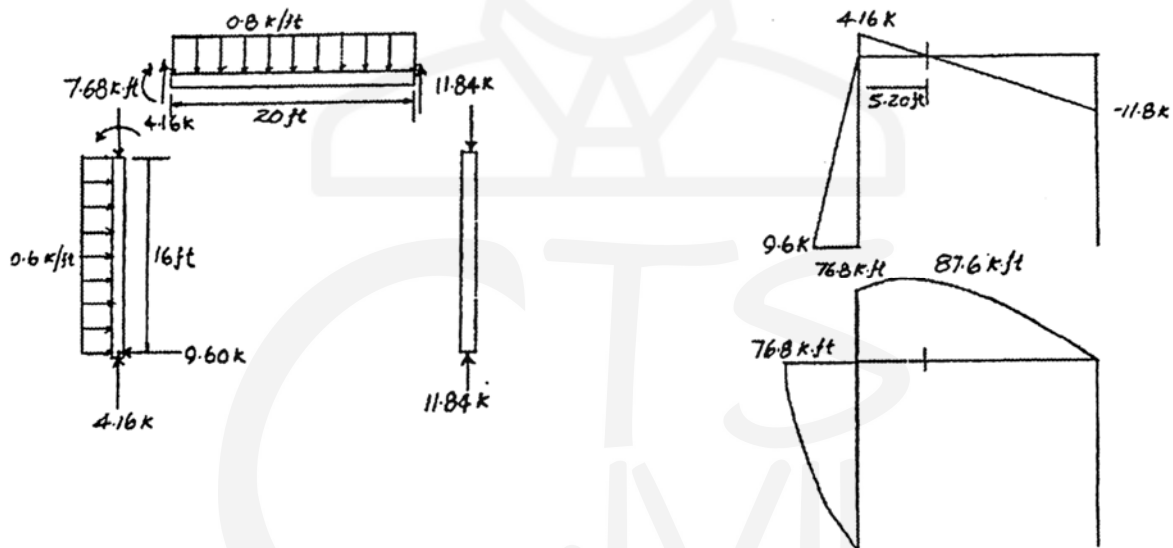

Example (2):

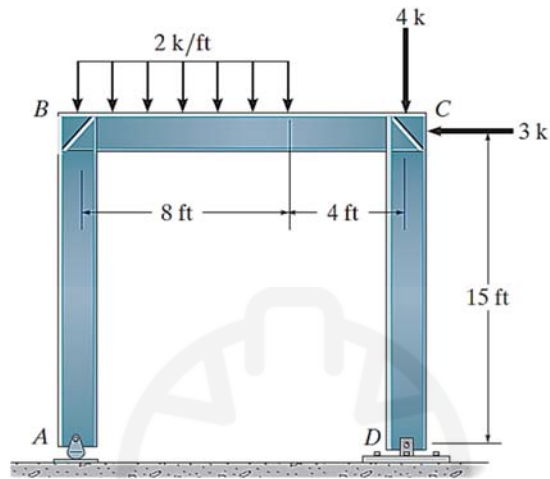

Solution:

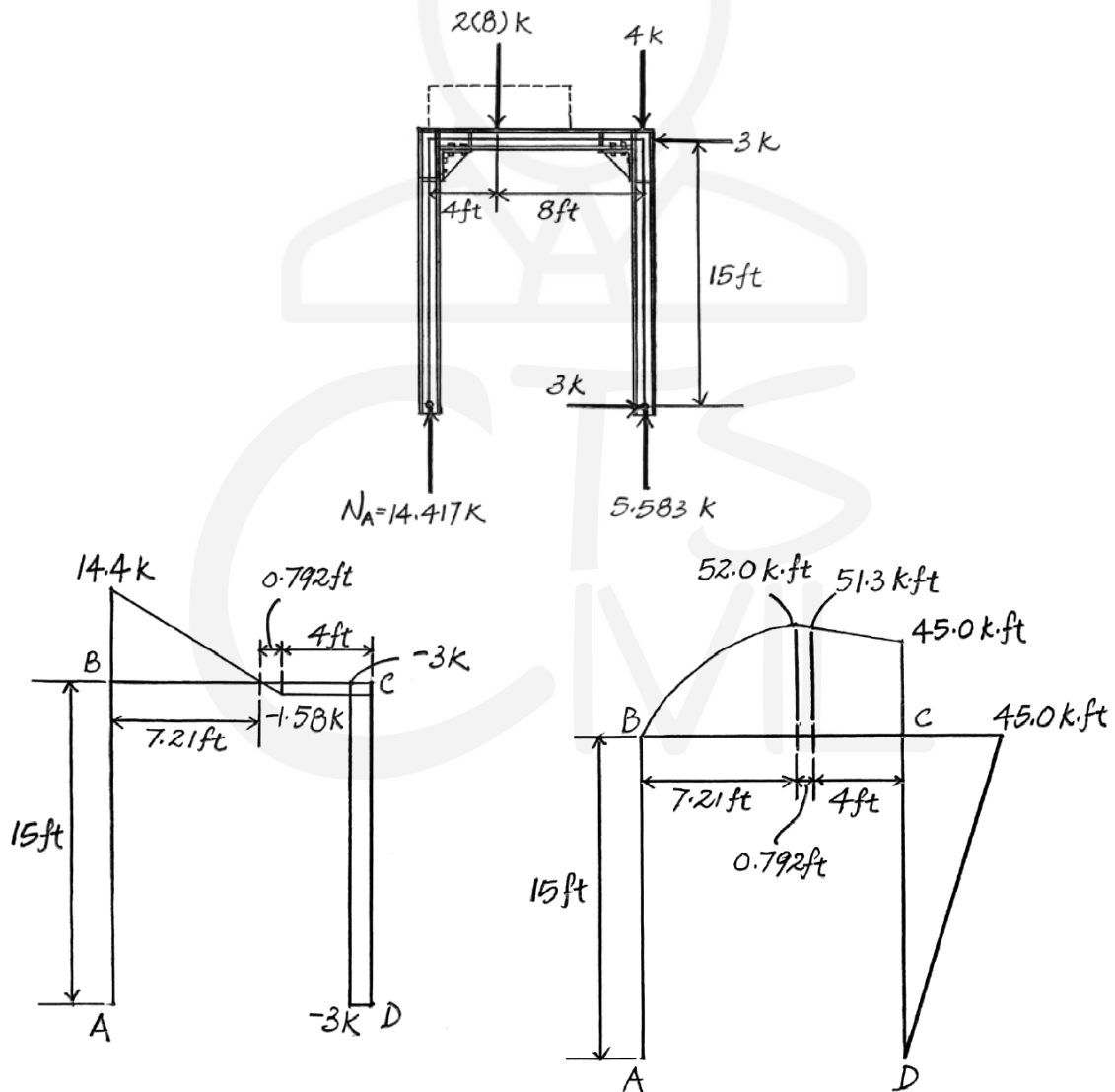

Example (3):

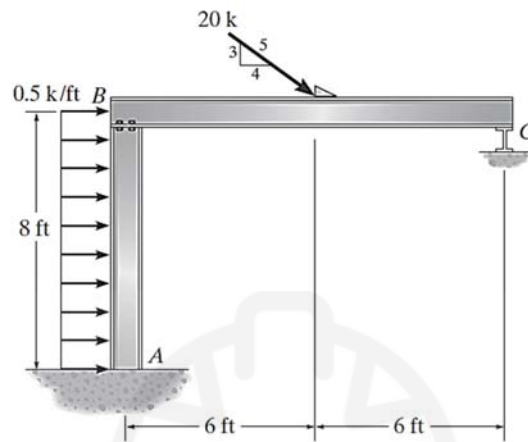

A → Fixed, C → Roller

Solution:

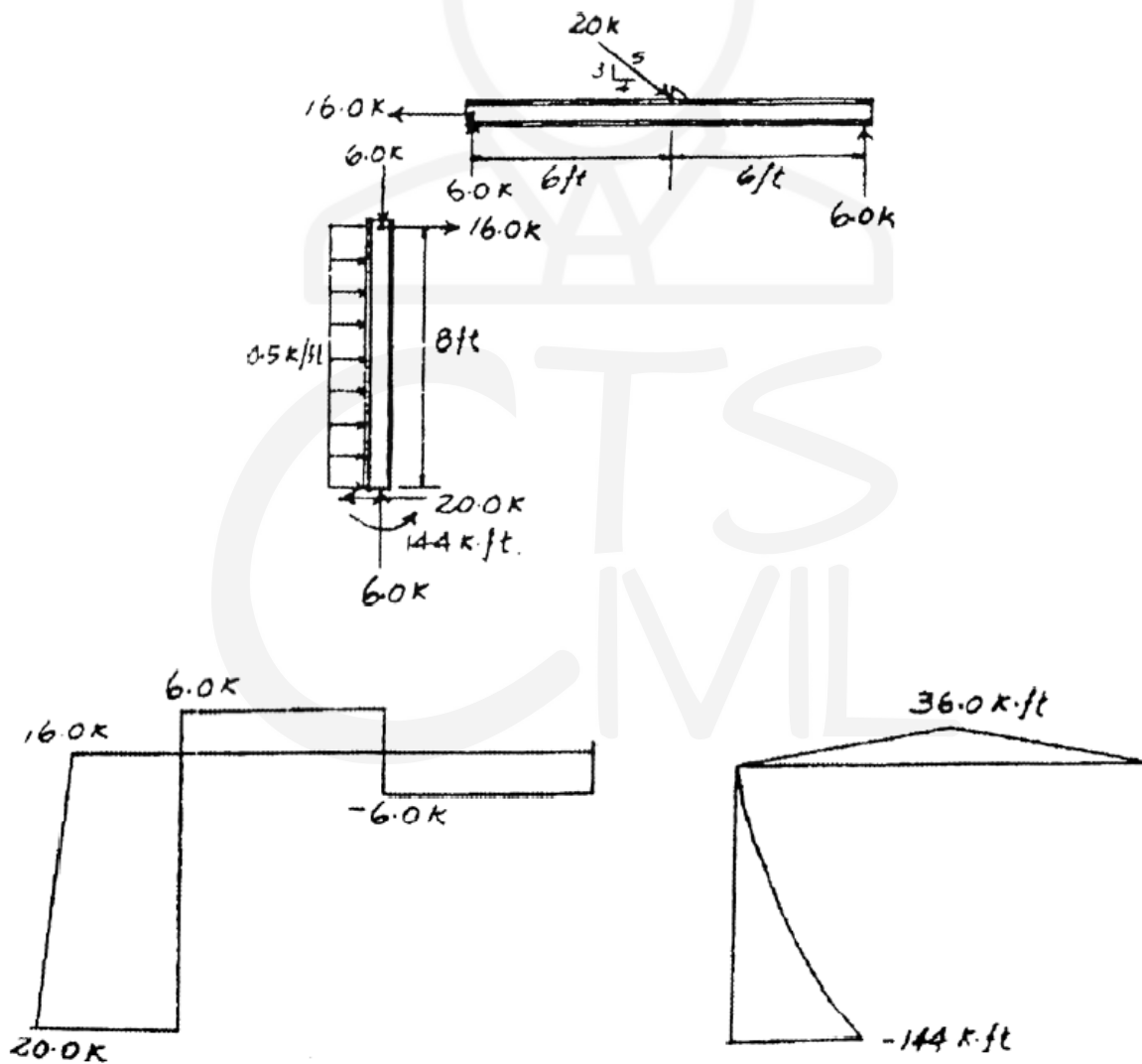

4.3 Shear Force and Bending Moment Diagrams:

4.3.1 Procedure for Analysis:

The following step-by-step procedure can be used for determining the member end forces as well as the shears, bending moments, and axial forces in members of plane statically determinate frames:

1. Check for static determinacy. Using the procedure described in the preceding section, determine whether or not the given frame is statically determinate. If the frame is found to be statically determinate and stable, proceed to step 2. Otherwise, end the analysis at this stage.
2. Determine the support reactions. Draw a free-body diagram of the entire frame, and determine reactions by applying the equations of equilibrium and any equations of condition that can be written in terms of external reactions only (without involving any internal member forces). For some internally unstable frames, it may not be possible to express all the necessary equations of condition exclusively in terms of external reactions; therefore, it may not be possible to determine all the reactions. However, some of the reactions for such structures can usually be calculated from the available equations.
3. Determine member end forces. It is usually convenient to specify the directions of the unknown forces at the ends of the members of the frame by using a common structural (or global) XY coordinate system, with the X and Y axes oriented in the horizontal (positive to the right) and vertical (positive upward) directions, respectively. Draw free-body diagrams of all the members and joints of the structure. These free-body diagrams must show, in addition to any external loads and support reactions, all the internal forces being exerted upon the member or the joint. Remember that a rigid joint is capable of transmitting two force components and a couple, a hinged joint can transmit two force components, and a roller joint can transmit only one force component. If there is a hinge at an end of a member, the internal moment at that end should be set equal to zero. Any load acting at a joint should be shown on the free-body diagrams of the joint, not at the ends of the members connected to the joint. The senses of the member end forces are not known and can be arbitrarily assumed. However, it is usually convenient to assume the senses of the unknown forces at member ends in the positive X and Y directions and of the unknown couples as counterclockwise. The senses of the internal forces and couples on the free-body diagrams of joints must be in directions opposite to those assumed on the member ends in accordance with Newton's third law. Compute the member end forces as follows:
 - a. Select a member or a joint with three or fewer unknowns.

- b. Determine the unknown forces and moments by applying the three equations of equilibrium to the free body of the member or joint selected in step 3(a).
- c. If all the unknown forces, moments, and reactions have been determined, then proceed to step 3(d). Otherwise, return to step 3(a).
- d. Since the support reactions were calculated in step 2 by using the equations of equilibrium and condition of the entire structure, there should be some equations remaining that have not been utilized so far. The number of leftover equations should be equal to the number of reactions computed in step 2. Use these remaining equations to check the calculations. If the analysis has been carried out correctly, then the remaining equations must be satisfied.

For some types of frames, a member or a joint that has a number of unknowns less than or equal to the number of equilibrium equations may not be found to start or continue the analysis. In such a case, it may be necessary to write equilibrium equations in terms of unknowns for two or more free bodies and solve the equations simultaneously to determine the unknown forces and moments.

4. For each member of the frame, construct the shear, bending moment, and axial force diagrams as follows:
 - a. Select a member (local) xy coordinate system with origin at either end of the member and x axis directed along the centroidal axis of the member. The positive direction of the y axis is chosen so that the coordinate system is right-handed, with the z axis pointing out of the plane of the paper.
 - b. Resolve all the external loads, reactions, and end forces acting on the member into components in the x and y directions (i.e., in the directions parallel and perpendicular to the centroidal axis of the member). Determine the total (resultant) axial force and shear at each end of the member by algebraically adding the x components and y components, respectively, of the forces acting at each end of the member.
 - c. Construct the shear and bending moment diagrams for the member by using the procedure described before. The procedure can be applied to non-horizontal members by considering the member end at which the origin of the xy coordinate system is located as the left end of the member (with x axis pointing toward the right) and the positive y direction as the upward direction.
 - d. Construct the axial force diagram showing the variation of axial force along the length of the member. Such a diagram can be constructed by using the method of sections. Proceeding in the positive x direction from the member end at which the origin of the xy coordinate system is located, sections are passed after each successive change in loading along the length of the member to determine the equations for the axial force in terms of x . According to the

sign convention adopted before, the external forces acting in the negative x direction (causing tension at the section) are considered to be positive. The values of axial forces determined from these equations are plotted as ordinates against x to obtain the axial force diagram.

5. Draw a qualitative deflected shape of the frame. Using the bending moment diagrams constructed in step 4, draw a qualitative deflected shape for each member of the frame. The deflected shape of the entire frame is then obtained by connecting the deflected shapes of the individual members at joints so that the original angles between the members at the rigid joints are maintained and the support conditions are satisfied. The axial and shear deformations, which are usually negligibly small as compared to the bending deformations, are neglected in sketching the deflected shapes of frames.

It should be noted that the bending moment diagrams constructed by using the procedure described in step 4(c) will always show moments on the compression sides of the members. For example, at a point along a vertical member, if the left side of the member is in compression, then the value of the moment at that point will appear on the left side. Since the side of the member on which a moment appears indicates the direction of the moment, it is not necessary to use plus and minus signs on the moment diagrams. When designing reinforced concrete frames, the moment diagrams are sometimes drawn on the tension sides of the members to facilitate the placement of steel bars used to reinforce concrete that is weak in tension. A tension-side moment diagram can be obtained by simply inverting (i.e., rotating through 180 degrees about the member's axis) the corresponding compression-side moment diagram. Only compression-side moment diagrams are considered in this text.

4.3.2 Examples:

Example (1):

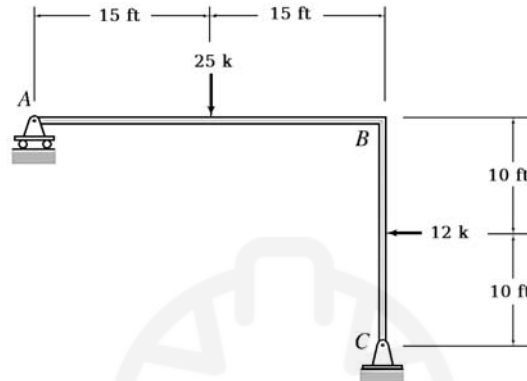

Solution:

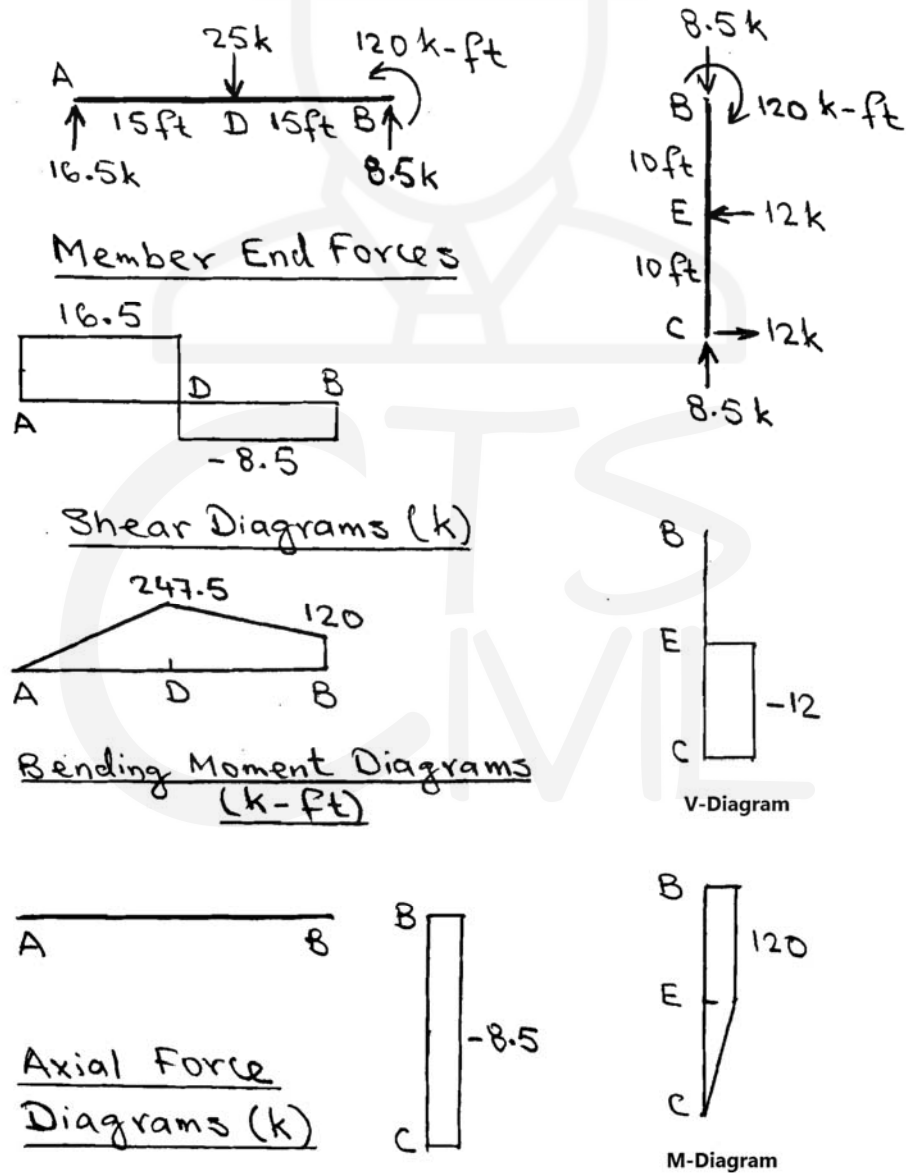

Example (2):

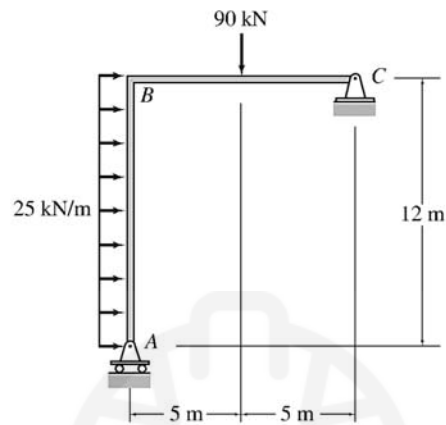

Solution:

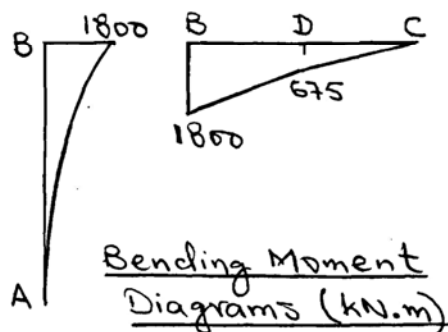
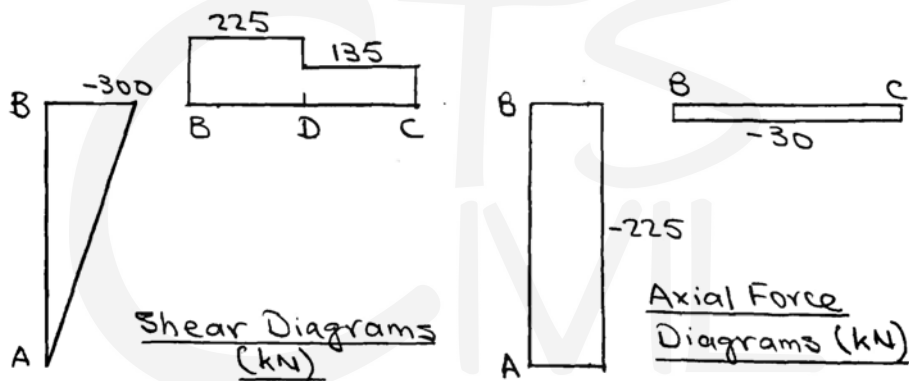
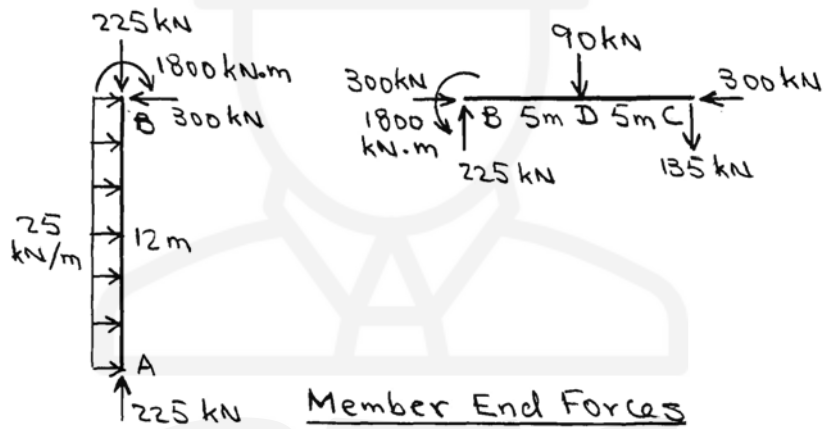

Example (3):

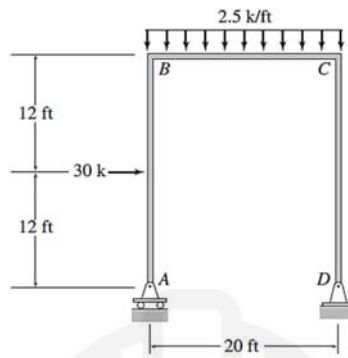

Solution:

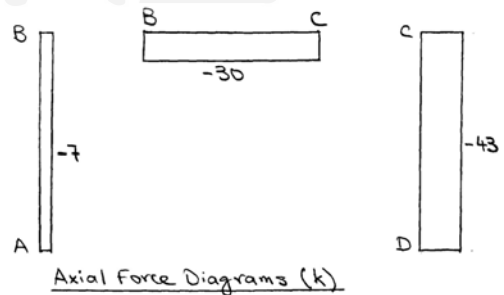
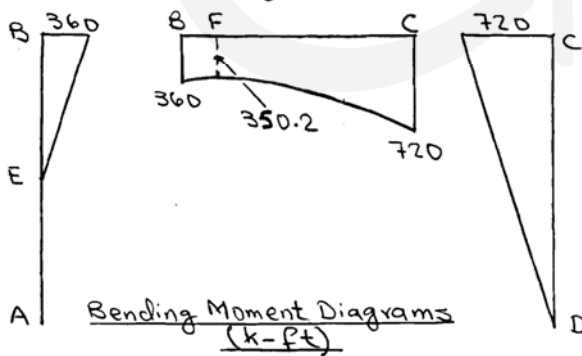
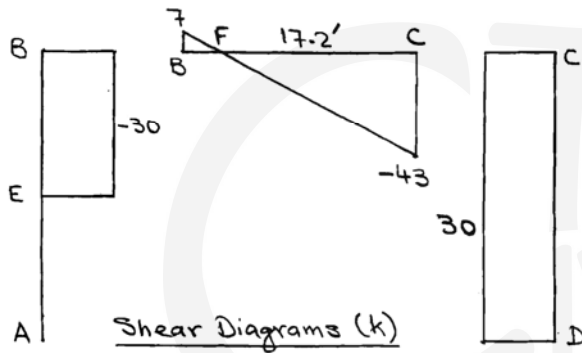
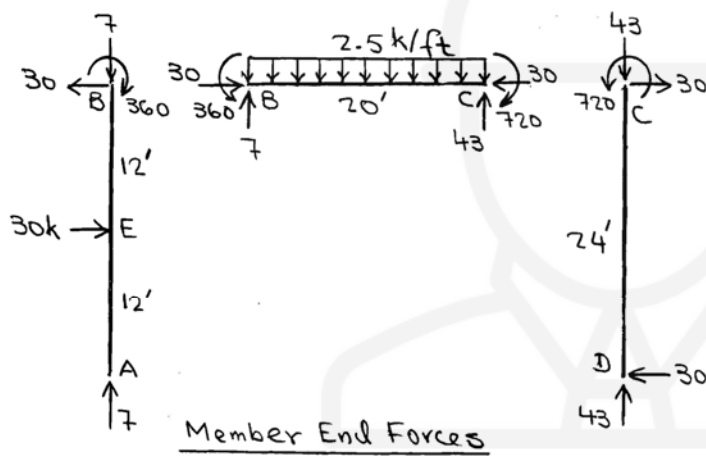

Example (4):

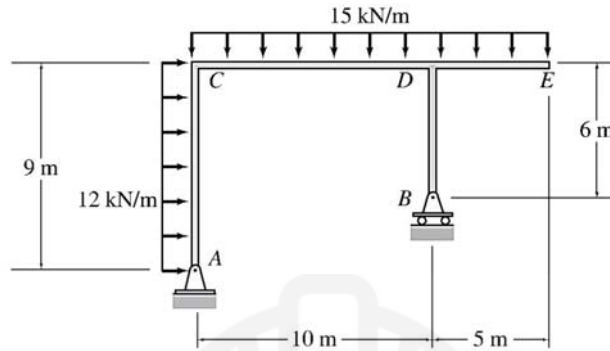

Solution:

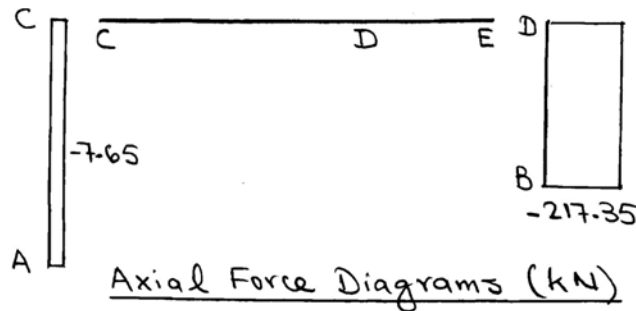
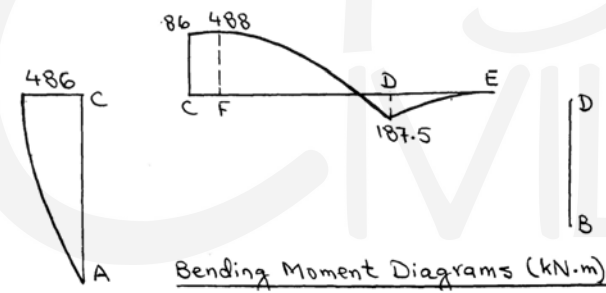
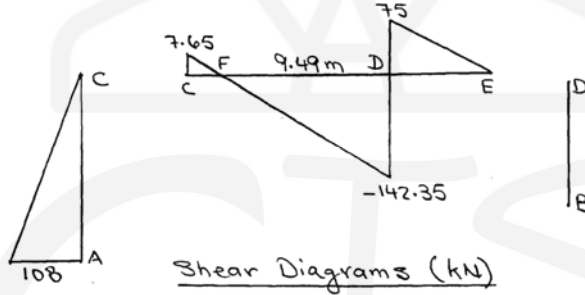
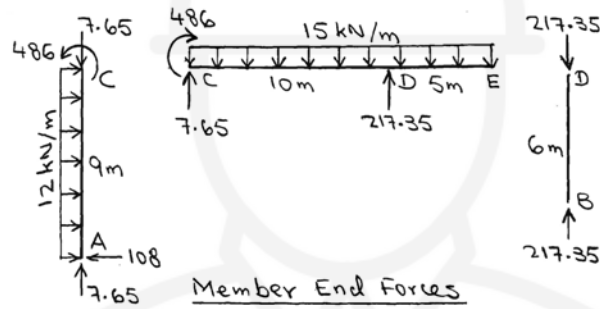

4.4 Problems:

Calculate the supports reactions for the following frames:

Frame 1:

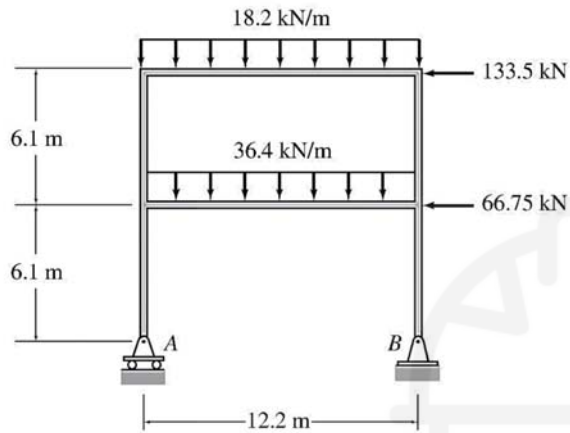

Frame 2:

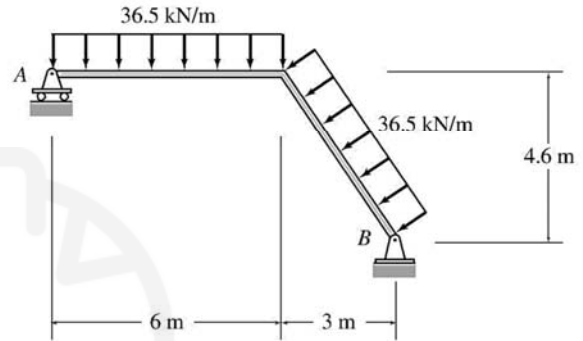

Frame 3:

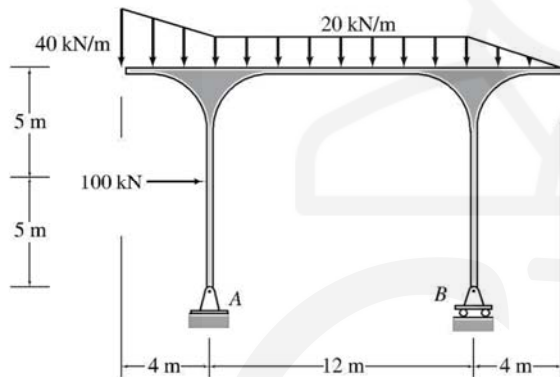

Frame 4:

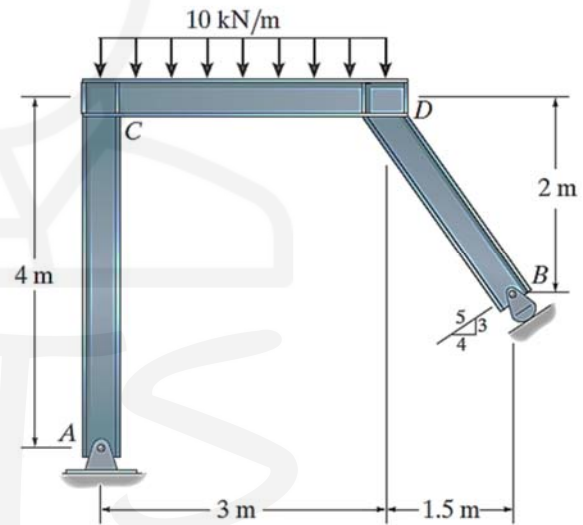

Draw the shear force and bending moment diagrams for the following frames:

Frame 5:

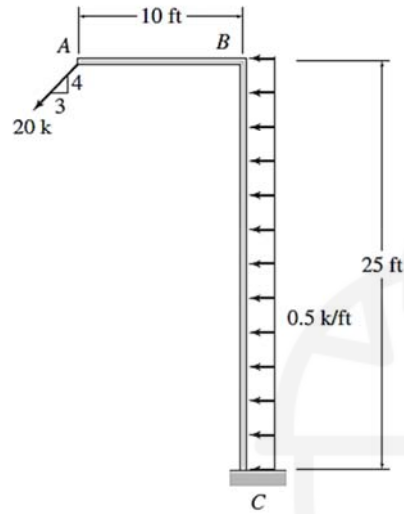

Frame 6:

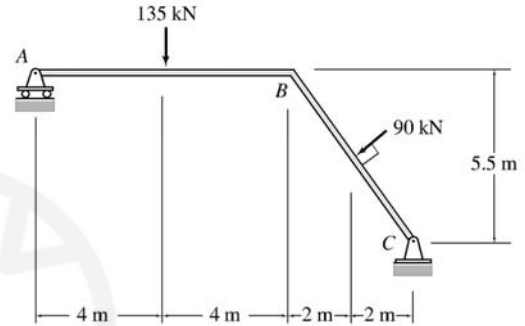

Frame 7:

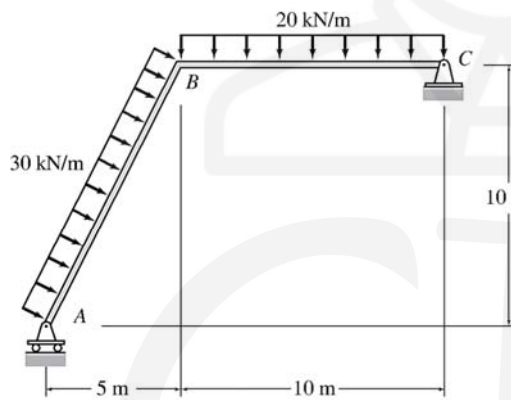

Frame 8:

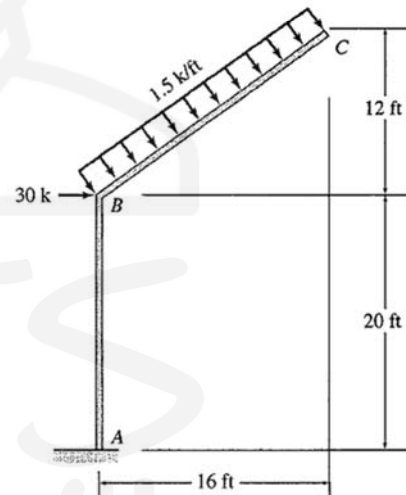

Chapter (5): Beam Deflection

5.1 Introduction:

The axis of a beam deflects from its initial position under action of applied forces. Accurate values for these beam deflections are sought in many practical cases: elements of machines must be sufficiently rigid to prevent misalignment and to maintain dimensional accuracy under load; in buildings, floor beams cannot deflect excessively to avoid the undesirable psychological effect of flexible floors on occupants and to minimize or prevent distress in brittle-finish materials; likewise, information on deformation characteristics of members is essential in the study of vibrations of machines as well as of stationary and flight structures.

5.2 Factors Affecting Beam Deflections

Factor	Symbol	Type
Span length	l	Directly proportional
Applied load	w	Directly proportional
Modulus of Elasticity	E	Inversely proportional
Moment of Inertia	I	Inversely proportional

5.3 Calculating Beam Deflections:

Calculations of beam deflections will depend on the formulae provided in the cases below.

5.4 Examples:

Example (1):

For the beam shown in the figure below, calculate the deflection of the beam at the mid-span.

Given: $E = 200 \text{ GPa}$, $I = 200 \times 10^6 \text{ mm}^4$

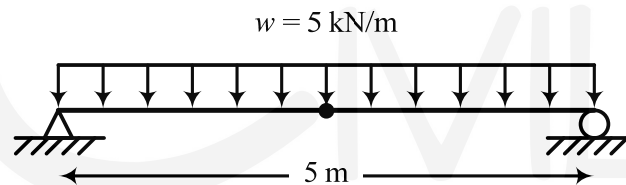

Solution:

$$w = 5 \text{ kN/m} \times \frac{1 \text{ m}}{1000 \text{ mm}} = 0.005 \text{ kN/mm}, \quad L = 5 \text{ m} = 5000 \text{ mm}, \quad E = 200 \text{ GPa} = 200 \text{ kN/mm}^2$$

$$\Delta = \frac{5 w l^4}{384 EI} = \frac{5 (0.005 \text{ kN/mm})(5000 \text{ mm})^4}{384 (200 \text{ kN/mm}^2)(200 \times 10^6 \text{ mm}^4)} = \boxed{1.017 \text{ mm}}$$

Example (2):

For the beam shown in the figure below, calculate the deflection of the beam at the free end.

Given: $E = 90 \text{ GPa}$, $I = 100 \times 10^6 \text{ mm}^4$ $E = 90 \text{ GPa}$, $I = 100 \times 10^6 \text{ mm}^4$

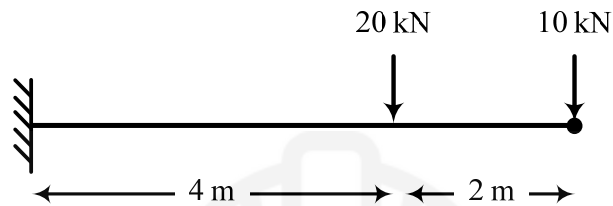
**Solution:**

$$P_1 = 10 \text{ kN} \quad P_2 = 20 \text{ kN} \quad l = 6 \text{ m} = 6000 \text{ mm} \quad I = 100 \times 10^6 \text{ mm}^4$$

$$x = 2 \text{ m} = 2000 \text{ mm} \quad b = 4 \text{ m} = 4000 \text{ mm} \quad E = 90 \text{ GPa} = 90 \text{ kN/mm}^2$$

$$\Delta_1 = \frac{P_1}{6EI} (2l^3 - 3l^2x + x^3)$$

$$= \frac{(10 \text{ kN})}{6(90 \text{ kN/mm}^2)(100 \times 10^6 \text{ mm}^4)} (2(6000 \text{ mm})^3 - 3(6000 \text{ mm})^2(2000 \text{ mm}) + (2000 \text{ mm})^3)$$

$$= 41.48 \text{ mm}$$

$$\Delta_2 = \frac{P_2 b^2}{6EI} (3l - 3x - b)$$

$$= \frac{(20 \text{ kN})(4000 \text{ mm})^2}{6(90 \text{ kN/mm}^2)(100 \times 10^6 \text{ mm}^4)} (3(6000 \text{ mm}) - 3(2000 \text{ mm}) - (4000 \text{ mm}))$$

$$= 47.41 \text{ mm}$$

$$\Delta = \Delta_1 + \Delta_2 = 41.48 \text{ mm} + 47.41 \text{ mm} = \boxed{88.88 \text{ mm}}$$

Example (3):

For the beam shown in the figure below, calculate the deflection of the beam at point C.

Given: $E = 100 \text{ GPa}$, $I = 120 \times 10^6 \text{ mm}^4$

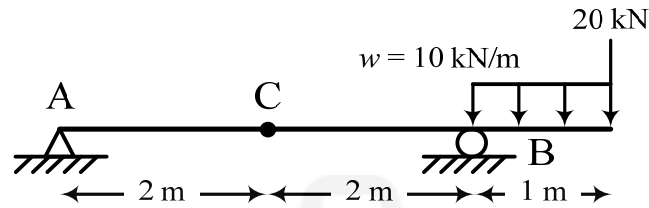

Solution:

$$w = 10 \text{ kN/m} \times \frac{1 \text{ m}}{1000 \text{ mm}} = 0.01 \text{ kN/mm} \quad l = 5 \text{ m} = 5000 \text{ mm} \quad E = 100 \text{ GPa} = 100 \text{ kN/mm}^2$$

$$P = 10 \text{ kN} \quad x = 2 \text{ m} = 2000 \text{ mm} \quad a = 2 \text{ m} = 2000 \text{ mm} \quad I = 120 \times 10^6 \text{ mm}^4$$

$$\begin{aligned} \Delta_1 &= \frac{Pax}{6EI} (l^2 - x^2) \\ &= \frac{(10 \text{ kN})(2000 \text{ mm})^2 (2000 \text{ mm})}{6(120 \text{ kN/mm}^2)(100 \times 10^6 \text{ mm}^4)} ((5000 \text{ mm})^2 - (2000 \text{ mm})^2) \\ &= 2.33 \text{ mm} \end{aligned}$$

$$\begin{aligned} \Delta_2 &= \frac{wax^2}{6EI} (l^2 - x^2) \\ &= \frac{(0.01 \text{ kN/mm})(2000 \text{ mm})(2000 \text{ mm})}{6(120 \text{ kN/mm}^2)(100 \times 10^6 \text{ mm}^4)} ((5000 \text{ mm})^2 - (2000 \text{ mm})^2) \\ &= 1.17 \text{ mm} \end{aligned}$$

$$\Delta = \Delta_1 + \Delta_2 = 2.33 \text{ mm} + 1.17 \text{ mm} = \boxed{3.5 \text{ mm}}$$

Example (4):

For the beam shown in the figure below, calculate the deflection of the beam at the mid-span. Given: $E = 95 \text{ GPa}$, $I = 100 \times 10^6 \text{ mm}^4$

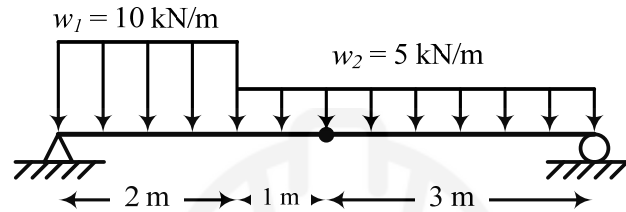
**Solution:**

$$w_1 = w_2 = 5 \text{ kN/m} \times \frac{1 \text{ m}}{1000 \text{ mm}} = 0.005 \text{ kN/mm}$$

$$l = 6 \text{ m} = 6000 \text{ mm} \quad E = 95 \text{ GPa} = 95 \text{ kN/mm}^2$$

$$x = 3 \text{ m} = 3000 \text{ mm} \quad a = 2 \text{ m} = 2000 \text{ mm} \quad I = 100 \times 10^6 \text{ mm}^4$$

$$\Delta_1 = \frac{5w_1 l^4}{384EI} = \frac{5(0.005 \text{ kN/mm})(6000 \text{ mm})^4}{384(95 \text{ kN/mm}^2)(100 \times 10^6 \text{ mm}^4)} = 8.88 \text{ mm}$$

$$\begin{aligned} \Delta_2 &= \frac{wa^2(l-x)}{24EI} (4xl - 2x^2 - a^2) \\ &= \frac{(0.005 \text{ kN/mm})(2000 \text{ mm})^2 (6000 \text{ mm} - 3000 \text{ mm})}{24(95 \text{ kN/mm}^2)(100 \times 10^6 \text{ mm}^4)(6000 \text{ mm})} \\ &\quad \times (4(3000 \text{ mm})(6000 \text{ mm}) - 2(3000 \text{ mm})^2 - (2000 \text{ mm})^2) \\ &= 2.19 \text{ mm} \end{aligned}$$

$$\Delta = \Delta_1 + \Delta_2 = 8.88 \text{ mm} + 2.19 \text{ mm} = \boxed{11 \text{ mm}}$$

5.5 Problems:

Question № 1:

For the beam shown in the figure (1) below, calculate the deflection of the beam at the mid-span. assuming $E = 80 \text{ GPa}$ and $I = 130 \times 10^6 \text{ mm}^4$.

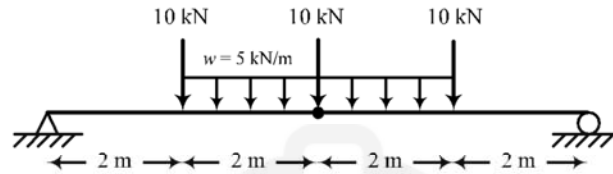

Figure 1

Question № 2:

Determine the displacement at point B for the cantilever beam shown in the figure assuming $E = 29000 \text{ ksi}$.

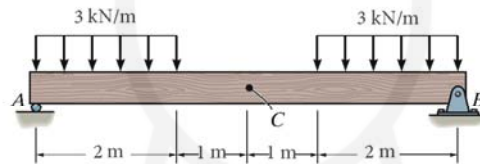

Figure 2

Question № 3:

Determine the deflection of the point located at mid-span between supports A and B for the beam shown in the figure. Assume $E = 200 \text{ GPa}$ and $I = 54 \times 10^6 \text{ mm}^4$.

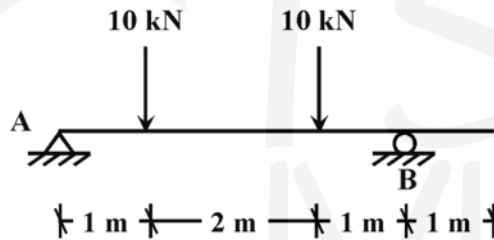
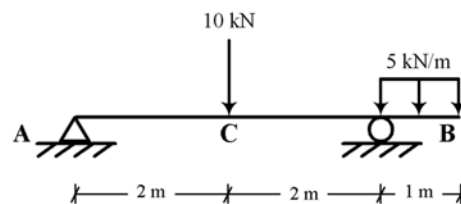

Figure 3

Question № 4:

Calculate the total displacement at point C of the beam shown in the figure given that $I = 60 \times 10^6 \text{ mm}^4$, and $E = 200 \text{ GPa}$.



Question № 3

Chapter (6): Loads on Structures

6.1 Live Load Reduction:

6.1.1 Floors:

- For some types of buildings having very large floor areas, many codes will allow a reduction in the uniform live load for a floor.
- The reason is that it is unlikely to that the prescribed live load will occur simultaneously throughout the entire structure at any one time.
- ASCE7-02 allows a reduction of live load on a member having an influence area ($K_{LL} A_T$) of 400 ft² (37.2 m²) or more.

$$L = L_o \left(0.25 + \frac{4.57}{\sqrt{K_{LL} A_T}} \right) \quad (\text{SI}) \quad (6-1)$$

$$L = L_o \left(0.25 + \frac{15}{\sqrt{K_{LL} A_T}} \right) \quad (\text{USCU}) \quad (6-2)$$

Where,

L = reduced design live load per square foot or square meter of area supported by the member, $> 0.5 L_o$ for 1 floor, $> 0.4 L_o$ for 2 floors or more.

L_o = unreduced design live load per square foot or square meter of area supported by the member.

K_{LL} = live load element factor.

A_T = Tributary area in square meters or feet.

NOTE:

Case	Exception
<p>Heavy Live Loads: Live loads that exceed 4.79kN/m² (100 lb/ft²) shall not be reduced</p>	Live loads for members supporting two or more floors shall be permitted to be reduced by 20 percent.
<p>Passenger Vehicle Garages: The live loads shall not be reduced in passenger vehicle garages.</p>	Live loads for members supporting two or more floors shall be permitted to be reduced by 20 percent.
<p>Assembly Uses: Live loads shall not be reduced in assembly uses.</p>	-

Element	<i>K_{LL}</i>
Interior columns	4
Exterior columns without cantilever slabs	4
Edge columns with cantilever slabs	3
Corner columns with cantilever slab	2
Edge beams without cantilever slabs	2
Interior beams	2
All other members not identified, including:	1
Edge beams with cantilever slabs	
Cantilever beams	
One-way slabs	
Two-way slabs	
Members without provisions for continuous shear transfer normal to their span	

Illustrating some of the elements in the table above, and referring to the plan in Figure 6-1 :

Element	Example
Slabs	
One-way slab	S2
Two-way slab	S3
Columns	
Interior columns	C4
Exterior columns without cantilever slabs	C5
Edge columns with cantilever slabs	B3
Corner columns with cantilever slab	B2
Beams	
Interior beams	C2 – C5
Cantilever beams	D1 – D2
Edge beams without cantilever slabs	B5 – C5
Edge beams with cantilever slabs	B3 – B4

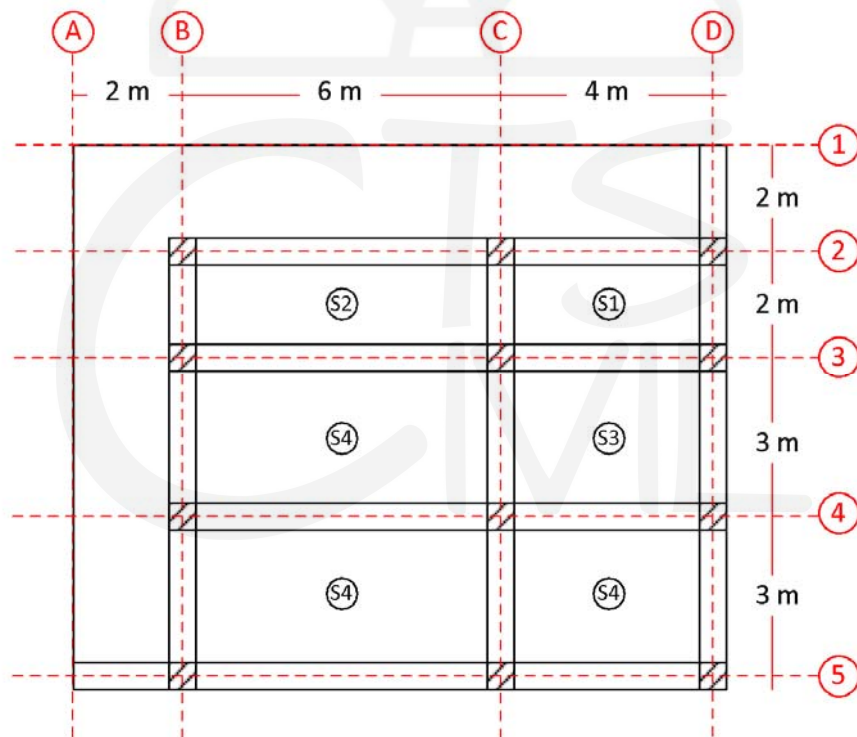

Figure 6-1: Floor plan

6.1.2 Roofs:

Ordinary flat, pitched, and curved roofs are permitted to be designed for a reduced roof live load in accordance with equation (4-2) from ASCE-7

$$L_r = L_o R_1 R_2 \quad (6-3)$$

Where

$$0.58 \leq L_r \leq 0.96 \quad (\text{SI}) \quad (6-4)$$

$$12 \leq L_r \leq 20 \quad (\text{USCU}) \quad (6-5)$$

L_r : reduced roof live load per ft² (m²) of horizontal projection in pounds per ft² (kN/m²)

The reduction factors R_1 and R_2 shall be determined as follows:

For R_1 :

$$R_1 = \begin{cases} 1 & \text{for } A_T \leq 200 \text{ ft}^2 \\ 1.5 - 0.001A_T & \text{for } 200 \text{ ft}^2 < A_T < 600 \text{ ft}^2 \\ 0.6 & \text{for } A_T \geq 600 \text{ ft}^2 \end{cases} \quad (\text{USCU})$$

$$R_1 = \begin{cases} 1 & \text{for } A_T \leq 18.58 \text{ m}^2 \\ 1.2 - 0.011A_T & \text{for } 18.58 \text{ m}^2 < A_T < 55.74 \text{ m}^2 \\ 0.6 & \text{for } A_T \geq 55.74 \text{ m}^2 \end{cases} \quad (\text{SI})$$

And A_T = Tributary area supported by structural member in square meters or feet.

For R_2 :

$$R_2 = \begin{cases} 1 & \text{for } F \leq 4 \\ 1.2 - 0.05F & \text{for } 4 < F < 12 \\ 0.6 & \text{for } F \geq 12 \end{cases} \quad (\text{USCU})$$

where, for a pitched roof, F = number of inches of rise per foot (in SI: $F = 0.12 \times$ slope, with slope expressed in percentage points) and, for an arch or dome, F = rise-to-span ratio multiplied by 32.

6.2 Tributary Areas for beams and columns:

- Definition:
 - Beams: The area of slab that is supported by a particular beam is termed the beam's tributary area.
 - Columns: the area surrounding the column that is bounded by the panel centerlines
- Importance: to understand and determine the vertical loads transferred from slabs to beams and columns
- Notes:
 - Tributary area for interior columns is four time (4x) the tributary area typical corner column.



- Tributary area for beams surrounding a “square” slab share equal portion of the load applied to that slab.
- For rectangular slabs, the load shared by the beams in the short direction is triangular whereas the load shared by beams in the long direction is trapezoidal.

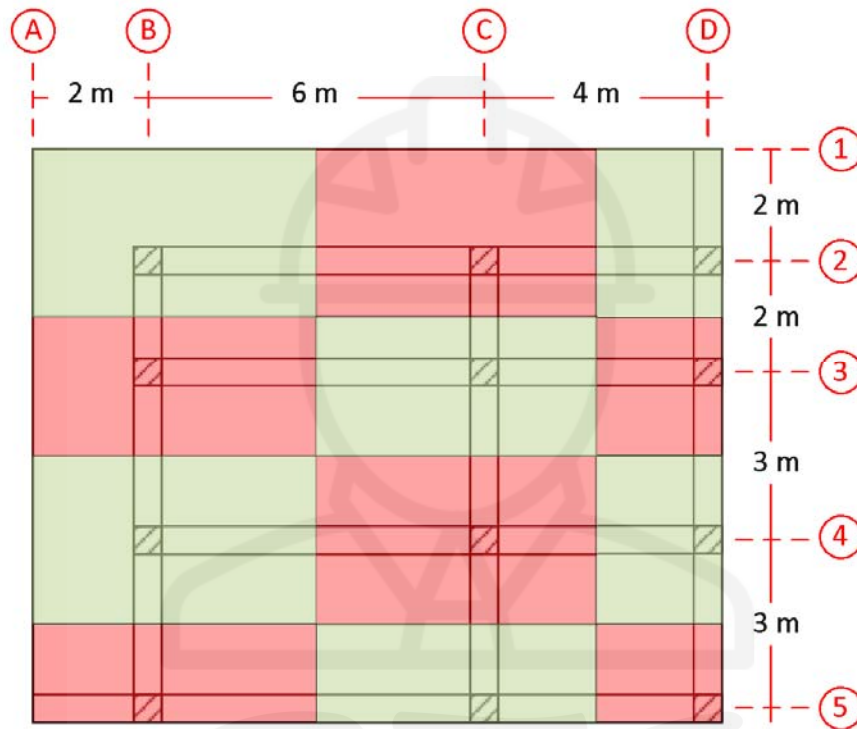

Figure 6-2: Tributary areas for different columns

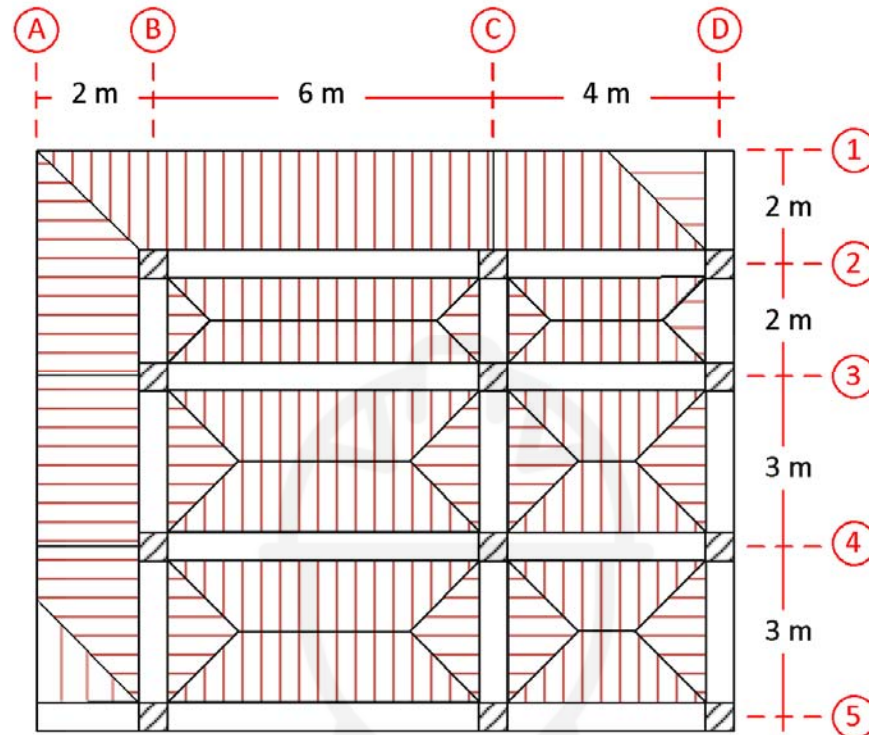

Figure 6-3: Tributary areas for different slabs

6.2.1 Approximate Methods:

Slab loads transmitted to beams can be calculated from the areas limited by lines bisecting the angles at the corners of any panel (tributary area). For convenience, these loads can be assumed as uniformly distributed over the beam span with some approximation techniques.

Assuming that:

- w : Uniformly distributed load per unit area
- L : Span of beams
- x : Maximum distance of loading to the desired beam
- αw : Equivalent load for bending moment calculations under the condition that the load is distributed over the total span of the beam with the maximum intensity at mid span.
- βw : Equivalent load for reaction and shear force and bending moment calculations for conditions not satisfied above.

where the values of α & β can be calculated from:

$$\alpha = 1 - \frac{1}{3} \left(\frac{2x}{L} \right)^2 \quad (6-6)$$

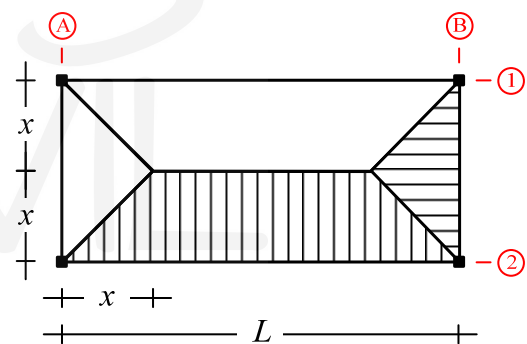

$$\beta = 1 - \frac{x}{L} \quad (6-7)$$

The following table contains some tabulated values for α & β

Table 1: Some tabulated values for (α & β)

$L/2x$	1.0	1.1	1.2	1.3	1.4	1.5	1.6	1.7	1.8	1.9	2.0
α	0.667	0.725	0.769	0.803	0.830	0.853	0.870	0.885	0.897	0.908	0.917
β	0.5	0.544	0.582	0.615	0.642	0.667	0.688	0.706	0.722	0.737	0.75

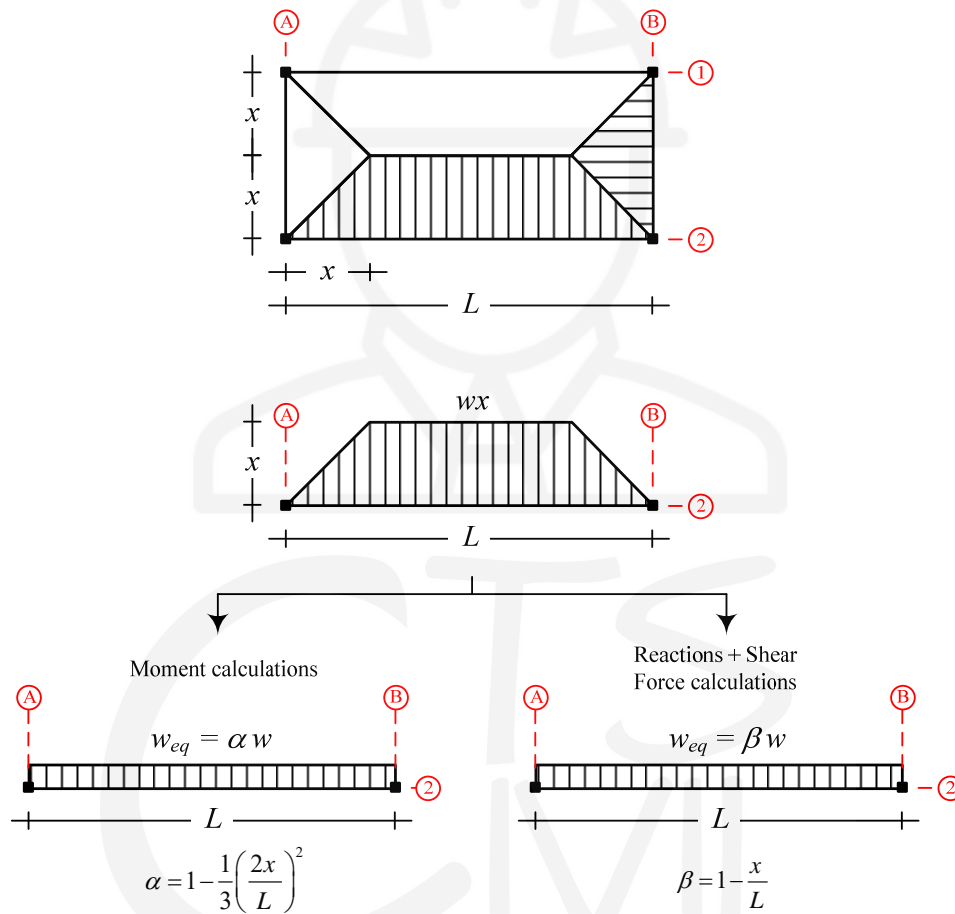

Figure 6-4: Steps in approximating trapezoidal load as a uniformly distributed load

6.3 Concepts in Structural Design:

- The design of any structure should account for safety, serviceability, and economy.
- Economy usually means less cost of construction materials resulting from smaller sections in general.
- This amount corresponds to the cross section with the smallest weight per unit length, which is the one with the smallest cross-sectional area.
- Other considerations, such as ease of construction, may ultimately affect the choice of member size.
- Having established this objective, the engineer must decide how to do it safely, which is where different approaches to design come into play.
- The fundamental requirement of structural design is that the required strength not exceed the available strength; that is,

$$\text{Required Strength} \leq \text{Available Strength}$$

6.3.1 LRFD:

- Load factors are applied to the service loads, and a member is selected that will have enough strength to resist the factored loads.
- In addition, the theoretical strength of the member is reduced by the application of a resistance factor.
- The criterion that must be satisfied in the selection of a member is

$$\text{Factored Load} \leq \text{Factored Strength}$$

- In this expression, the factored load is actually the sum of all service loads to be resisted by the member, each multiplied by its own load factor.
- The factored strength is the theoretical strength multiplied by a resistance factor. So,

$$\sum (\text{Load} \times \text{Load factor}) \leq \text{Resistance} \times \text{resistance factor}$$

- The factored load is a failure load greater than the total actual service load, so the load factors are usually greater than unity.
- However, the factored strength is a reduced, usable strength, and the resistance factor is usually less than unity.
- The factored loads are the loads that bring the structure or member to its limit.
- In terms of safety, this limit state can be fracture, yielding, or buckling, and the factored resistance is the useful strength of the member, reduced from the theoretical value by the resistance factor.
- The limit state can also be one of serviceability, such as a maximum acceptable deflection.

6.3.2 Load Combinations:

- We have seen that

$$\sum (\text{Load} \times \text{Load factor}) \leq \text{Resistance} \times \text{resistance factor}$$

- It can be written as

$$\sum \gamma_i Q_i \leq \phi R_n \quad (6-8)$$

Where:

γ_i : a load factor

Q_i : applied load

ϕ : resistance factor

R_n : the nominal resistance or strength

ϕR_n : the design strength

- The summation on the left side of the above expression is over the total number of load effects (including, but not limited to, dead load and live load), where each load effect can be associated with a different load factor.
- This can be obtained by what is known as “Load Combinations”
- Many structures will see most, if not all, the loads mentioned above sometime in their life.
- The next challenge becomes how to combine the loads reasonably.
- A direct combination of all the loads at their maximum is not considered to be probable.
- For example, it would not be reasonable to expect a full live load to occur simultaneously with a full snow load during a design level wind storm.
- The design of a structural member entails the selection of a cross section that will safely and economically resist the applied loads.

6.3.3 LRFD Load Combinations:

$$1.4(D + F) \quad (1)$$

$$1.2(D + F + T) + 1.6(L + H) + 0.5(L_r \text{ or } S \text{ or } R) \quad (2)$$

$$1.2D + 1.6(L_r \text{ or } S \text{ or } R) + (L \text{ or } 0.5W) \quad (3)$$

$$1.2D + 1.0W + 1.0L + 0.5(L_r \text{ or } S \text{ or } R) \quad (4)$$

$$1.2D + 1.0E + 1.0L + 0.2S \quad (5)$$

$$0.9D + 1.6W + 1.6H \quad (6)$$

$$0.9D + 1.0E + 1.6H \quad (7)$$

Where:

D = Dead load

F = Fluid Load

T = Self straining load

L = Live load

L_r = Roof live load

H = Lateral earth pressure, ground water pressure

S = Snow load

R = Rain load

W = Wind load

E = Earthquake load

Note:

Wind and earthquake loads will have compression and tensile components. For tensile, use negative value and positive value for compression loads.

6.3.4 Examples:**Example (1):**

The various axial loads for a building column have been computed according to the applicable building code with the following results:

dead load = 850 kN, load from roof = 250kN (roof live load), live load from floor = 1100 kN, compression wind = 350 kN, tensile wind = 290 kN, compression earthquake = 260 kN, and tensile earthquake = 300 kN.

Determine the ultimate load on the column.

Solution:

$D = 850$ kN, $F = 0$ kN, $T = 0$ kN, $L = 1100$ kN, $L_r = 250$ kN, $H = 0$ kN, $S = 0$ kN, $R = 0$ kN, $W = +350$ kN (Compression) and -290 kN (Tensile), $E = +260$ kN (Compression) and -300 kN (Tensile). After including all zero values of the loads in the load combinations, and expanding the equations to their permutations, the equations are reduced to:

$$1.4D$$

$$1.2D + 1.6L + 0.5L_r$$

$$1.2D + 1.6L_r + L$$

$$1.2D + 1.6L_r + 0.5W_{\text{tension}}$$

$$1.2D + 1.6L_r + 0.5W_{\text{compression}}$$

$$1.2D + 1.0W_{\text{tension}} + 1.0L + 0.5L_r$$

$$1.2D + 1.0W_{\text{compression}} + 1.0L + 0.5L_r$$

$$1.2D + 1.0L$$

$$0.9D + 1.6W_{\text{tension}}$$

$$0.9D + 1.6W_{\text{compression}}$$

$$0.9D + 1.0E_{\text{tensile}}$$

$$0.9D + 1.0E_{\text{compression}}$$



Substituting numerical values will lead to:

$$1.4(850) = 1190 \text{ kN}$$

$$1.2(850) + 1.6(1100) + 0.5(250) = \boxed{2905 \text{ kN}}$$

$$1.2(850) + 1.6(250) + (1100) = 2520 \text{ kN}$$

$$1.2(850) + 1.6(250) + 0.5(-290) = 1275 \text{ kN}$$

$$1.2(850) + 1.6(250) + 0.5(350) = 1595 \text{ kN}$$

$$1.2(850) + 1.0(-290) + 1.0(1100) + 0.5(250) = 1955 \text{ kN}$$

$$1.2(850) + 1.0(350) + 1.0(1100) + 0.5(250) = 2595 \text{ kN}$$

$$1.2(850) + 1.0(1100) = 2120 \text{ kN}$$

$$0.9(850) + 1.6(-290) = 301 \text{ kN}$$

$$0.9(850) + 1.6(350) = 1325 \text{ kN}$$

$$0.9(850) + 1.0(-300) = 465 \text{ kN}$$

$$0.9(850) + 1.0(260) = 1025 \text{ kN}$$

The ultimate load on the column = 2905 kN

Example (2):

For the floor plan shown in the figure (1), if $D = 3.4 \text{ kN/m}^2$ and $L = 2.4 \text{ kN/m}^2$, find the ultimate loads on:

- Columns A4, B3, and C4
- Beams B1 – C1 and C2 – D2

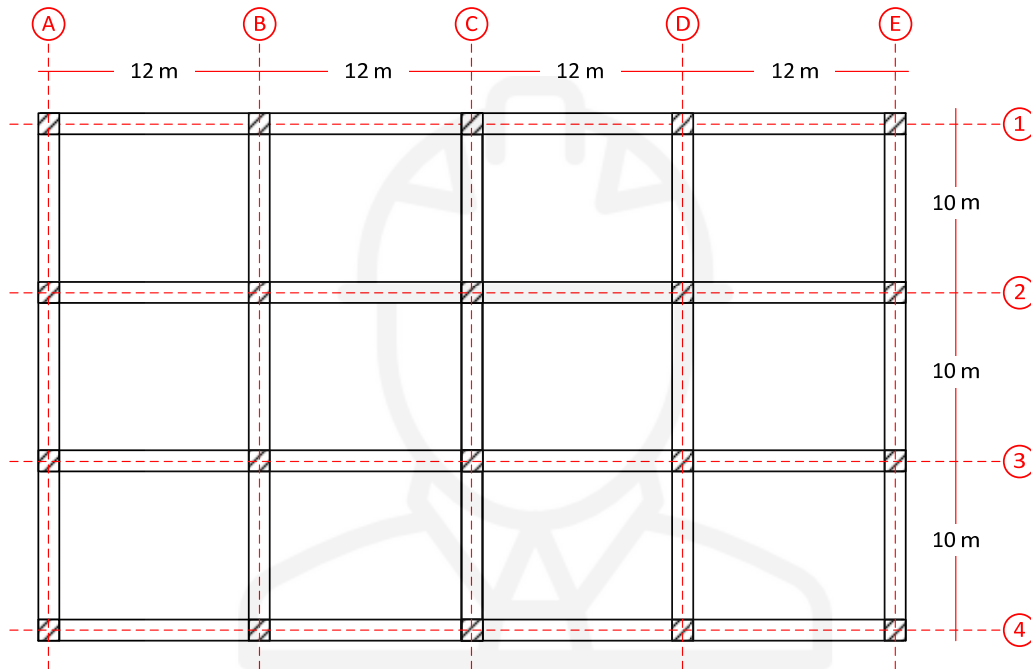

Figure 6-5: Floor plan for **Error! Reference source not found.**

Solution:**Column A4:**

$$A_T = 6 \times 5 = 30 \text{ m}^2$$

Column A4 is a corner column without cantilever slab $\rightarrow K_{LL} = 1$

$$A_I = K_{LL} \times A_T = 1 \times 30 = 30 \text{ m}^2$$

$A_I < 37.2 \text{ m}^2 \rightarrow$ No Reduction

$$P_u = (1.2D + 1.6L) \times A_I = (1.2(3.4) + 1.6(2.4)) \times 30 = \boxed{237.7 \text{ kN}}$$

Column B3:

$$A_T = 10 \times 12 = 120 \text{ m}^2$$

Column B3 is an interior column $\rightarrow K_{LL} = 4$

$$A_I = K_{LL} \times A_T = 4 \times 120 = 480 \text{ m}^2$$

$A_I > 37.2 \text{ m}^2 \rightarrow$ Apply live load reduction

$$L = L_o \left(0.25 + \frac{4.57}{\sqrt{A_I}} \right) = 2.4 \left(0.25 + \frac{4.57}{\sqrt{480}} \right) = 1.1 \text{ kN/m}^2$$

$$P_u = (1.2D + 1.6L) \times A_I = (1.2(3.4) + 1.6(1.1)) \times 120 = \boxed{700.8 \text{ kN}}$$

Column C4:

$$A_T = 5 \times 12 = 60 \text{ m}^2$$

Column C4 is an exterior column without cantilever slabs $\rightarrow K_{LL} = 4$

$$A_I = K_{LL} \times A_T = 4 \times 60 = 240 \text{ m}^2$$

$A_I > 37.2 \text{ m}^2 \rightarrow$ Apply live load reduction

$$L = L_o \left(0.25 + \frac{4.57}{\sqrt{A_I}} \right) = 2.4 \left(0.25 + \frac{4.57}{\sqrt{240}} \right) = 1.31 \text{ kN/m}^2$$

$$P_u = (1.2D + 1.6L) \times A_I = (1.2(3.4) + 1.6(1.31)) \times 60 = \boxed{370.6 \text{ kN}}$$

$$L = L_o \left(0.25 + \frac{4.57}{\sqrt{A_I}} \right) = 2.4 \left(0.25 + \frac{4.57}{\sqrt{240}} \right) = 1.31 \text{ kN/m}^2$$

Beam B1 – C1:

$$A_T = \left(\frac{12+2}{2} \right) \times 5 = 35 \text{ m}^2$$

Beam B1 – C1 is an edge beam without cantilever slabs $\rightarrow K_{LL} = 2$

$$A_I = K_{LL} \times A_T = 2 \times 35 = 70 \text{ m}^2$$

$A_I > 37.2 \text{ m}^2 \rightarrow$ Apply live load reduction

$$L = L_o \left(0.25 + \frac{4.57}{\sqrt{A_I}} \right) = 2.4 \left(0.25 + \frac{4.57}{\sqrt{70}} \right) = 1.89 \text{ kN/m}^2$$

$$W_u = (1.2D + 1.6L) \times \perp d = (1.2(3.4) + 1.6(1.89)) \times 5 = \boxed{35.52 \text{ kN/m}}$$

Extra: Approximation of trapezoidal load as a uniformly distributed load



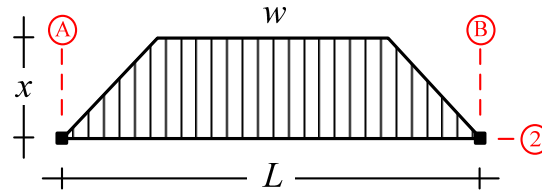

$$w = 35.52 \text{ kN/m}^2, x = 5 \text{ m}$$

$$\alpha = 1 - \frac{1}{3} \left(\frac{2x}{L} \right)^2 = 1 - \frac{1}{3} \left(\frac{2(5)}{12} \right)^2 = 0.769 \quad \beta = 1 - \frac{x}{L} = 1 - \frac{5}{12} = 0.583$$

Equivalent uniformly distributed load for bending moment:

$$w_{eq} = \alpha w = (0.769)(35.52) = 27.31 \text{ kN/m}$$

Equivalent uniformly distributed load for shear force:

$$w_{eq} = \beta w = (0.583)(35.52) = 20.72 \text{ kN/m}$$



Beam C2 – D2:

$$A_T = 2 \times \left(\frac{12+2}{2} \right) \times 5 = 70 \text{ m}^2$$

Beam C2 – D2 is an interior beam $\rightarrow K_{LL} = 2$

$$A_I = K_{LL} \times A_T = 2 \times 70 = 140 \text{ m}^2$$

$A_I > 37.2 \text{ m}^2 \rightarrow$ Apply live load reduction

$$L = L_o \left(0.25 + \frac{4.57}{\sqrt{A_I}} \right) = 2.4 \left(0.25 + \frac{4.57}{\sqrt{140}} \right) = 1.59 \text{ kN/m}^2$$

$$W_u = (1.2D + 1.6L) \times \perp d = (1.2(3.4) + 1.6(1.59)) \times 5 = \boxed{33.12 \text{ kN/m}}$$

Extra: Approximation of trapezoidal load as a uniformly distributed load

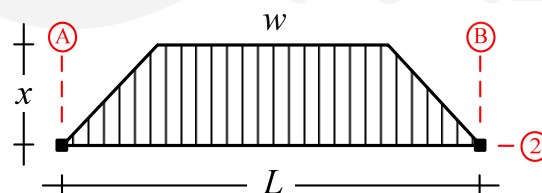

$$w = 33.2 \text{ kN/m}^2, x = 5 \text{ m}$$

$$\alpha = 1 - \frac{1}{3} \left(\frac{2x}{L} \right)^2 = 1 - \frac{1}{3} \left(\frac{2(5)}{12} \right)^2 = 0.769 \quad \beta = 1 - \frac{x}{L} = 1 - \frac{5}{12} = 0.583$$

Equivalent uniformly distributed load for bending moment:



$$w_{eq} = \alpha w = (0.769)(33.12) = 25.47 \text{ kN/m}$$

Equivalent uniformly distributed load for shear force:

$$w_{eq} = \beta w = (0.583)(33.12) = 19.31 \text{ kN/m}$$



Example (3):

For the 2nd floor plan shown in the figure below, assuming all slabs are 10 cm thick and:

- Concrete density (ρ) = 25 kN/m³
- Mechanical, Electrical, and Piping = 0.60 kN/m²
- Ceiling system = 0.30 kN/m²
- Roofing = 0.20 kN/m²
- Flooring = 0.35 kN/m²

1- Find the “ultimate load” on columns (A1), (B4), (C2)

2- Find the “ultimate load” on beams (A3 – A4), (C1 – C2), (B3 – C3)

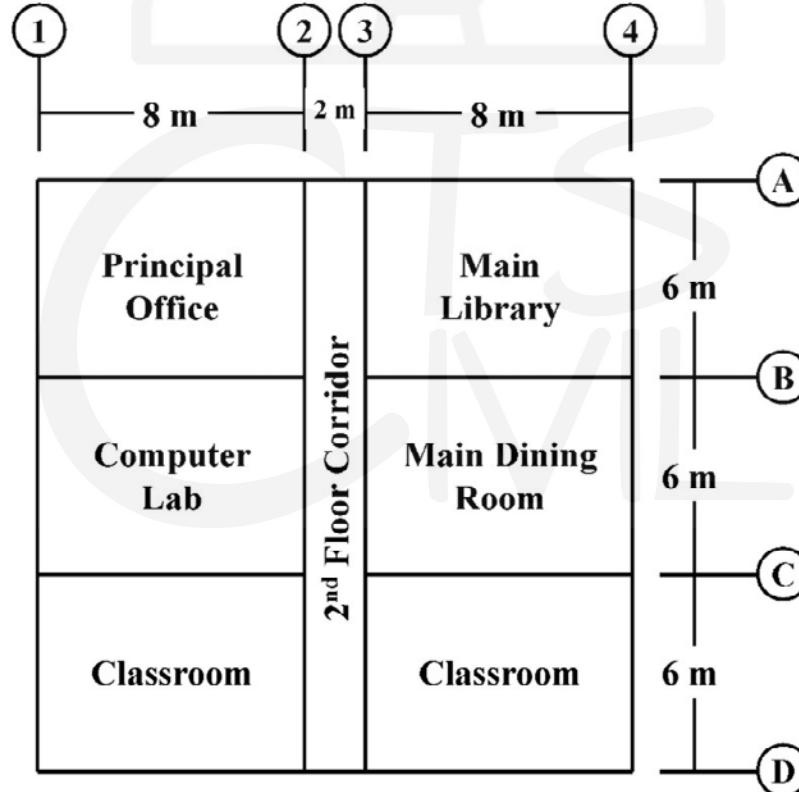

Figure 6-6: Floor plan for Error! Reference source not found.

Solution:

Dead load calculation:

$$\sum D = \left(25 \text{ kN/m}^3 \times \frac{10}{100} \text{ m} \right) + 0.60 + 0.30 + 0.35 = 3.75 \text{ kN/m}^2$$

Summary of live load values from ASCE-7:

Occupancy	Live load (kN/m ²)
Office	2.40
Computer Lab	4.79
Classroom	1.92
Corridor above first floor	3.83
Library (reading room)	2.87
Dining room	4.79

Column A1:

$$A_T = 4 \times 3 = 12 \text{ m}^2$$

Column A1 is a corner column without cantilever slab $\rightarrow K_{LL} = 1$

$$A_I = K_{LL} \times A_T = 1 \times 12 = 12 \text{ m}^2$$

 $A_I < 37.2 \text{ m}^2 \rightarrow$ No reduction

$$P_u = (1.2D + 1.6L) \times A_I = (1.2(3.75) + 1.6(2.4)) \times 12 = \boxed{100 \text{ kN}}$$

Column B4:

$$A_{T \text{ Lib}} = 3 \times 4 = 12 \text{ m}^2$$

Column B4 is an exterior column without cantilever slabs $\rightarrow K_{LL} = 4$

$$A_{I \text{ Lib}} = K_{LL} \times A_{T \text{ Lib}} = 4 \times 12 = 48 \text{ m}^2$$

 $A_I > 37.2 \text{ m}^2 \rightarrow$ Apply live load reduction

$$L = L_o \left(0.25 + \frac{4.57}{\sqrt{A_I}} \right) = 2.87 \left(0.25 + \frac{4.57}{\sqrt{48}} \right) = 2.61 \text{ kN/m}^2$$

$$P_{u \text{ Lib}} = (1.2D + 1.6L) \times A_{I \text{ Lib}} = (1.2(3.75) + 1.6(2.61)) \times 12 = \boxed{104.10 \text{ kN}}$$

Note: No reduction is allowed for dining room live load (ASCE-7)

$$A_{T \text{ Din}} = 3 \times 4 = 12 \text{ m}^2 = A_{I \text{ Din}}$$

$$P_{u \text{ Din}} = (1.2D + 1.6L) \times A_{I \text{ Din}} = (1.2(3.75) + 1.6(4.79)) \times 12 = \boxed{145.97 \text{ kN}}$$

$$\sum P_u = P_{u \text{ Lib}} + P_{u \text{ Din}} = 104.10 + 145.97 \approx \boxed{250 \text{ kN}}$$

Column C2:

$$w = 27.28 \text{ kN/m}^2, x = 3 \text{ m}$$

$$\alpha = 1 - \frac{1}{3} \left(\frac{2x}{L} \right)^2 = 1 - \frac{1}{3} \left(\frac{2(3)}{8} \right)^2 = 0.8125 \quad \beta = 1 - \frac{x}{L} = 1 - \frac{3}{8} = 0.625$$

Equivalent uniformly distributed load for bending moment:

$$w_{eq} = \alpha w = (0.8125)(27.28) = 22.17 \text{ kN/m}$$

Equivalent uniformly distributed load for shear force:

$$w_{eq} = \beta w = (0.625)(27.28) = 17.051 \text{ kN/m}$$



Beam C1 – C2:

$$A_{T \text{ Comp}} = A_{T \text{ Class}} = \left(\frac{2+8}{2} \right) \times 3 = 15 \text{ m}^2$$

Beam C1 – C2 is an interior beam $\rightarrow K_{LL} = 2$

$$A_{I \text{ Comp}} = A_{I \text{ Class}} = 2 \times 15 = 30 \text{ m}^2$$

$A_{I \text{ Comp}}, A_{I \text{ Class}} < 37.2 \text{ m}^2 \rightarrow$ No live load reduction

$$W_{u \text{ Comp}} = (1.2D + 1.6L) \times \perp d = (1.2(3.75) + 1.6(4.79)) \times 3 = \boxed{36.49 \text{ kN/m}}$$

$$W_{u \text{ Class}} = (1.2D + 1.6L) \times \perp d = (1.2(3.75) + 1.6(1.92)) \times 3 = \boxed{22.72 \text{ kN/m}}$$

$$\sum W_u = W_{u \text{ Comp}} + W_{u \text{ Class}} = 36.49 + 22.72 = \boxed{59.21 \text{ kN/m}}$$

Extra: Approximation of trapezoidal load as a uniformly distributed load

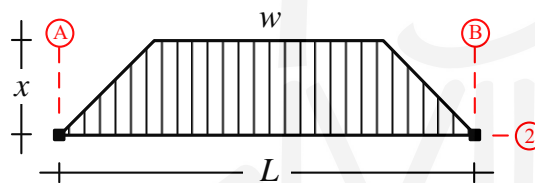

$$w = 59.21 \text{ kN/m}^2, x = 3 \text{ m}$$

$$\alpha = 1 - \frac{1}{3} \left(\frac{2x}{L} \right)^2 = 1 - \frac{1}{3} \left(\frac{2(3)}{8} \right)^2 = 0.8125 \quad \beta = 1 - \frac{x}{L} = 1 - \frac{3}{8} = 0.625$$

Equivalent uniformly distributed load for bending moment:

$$w_{eq} = \alpha w = (0.8125)(59.21) = 48.11 \text{ kN/m}$$

Equivalent uniformly distributed load for shear force:

$$w_{eq} = \beta w = (0.625)(59.21) = 37.011 \text{ kN/m}$$

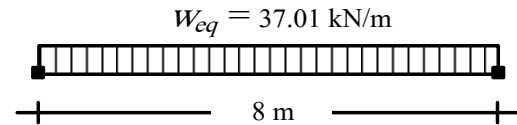
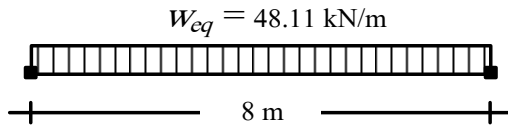

Beam B3 – C3:

$$A_{T \text{ Din}} = \frac{1}{2} \times 6 \times 3 = 9 \text{ m}^2$$

$$A_{T \text{ Corr}} = 1 \times 6 = 6 \text{ m}^2$$

Beam B3 – C3 is an interior beam $\rightarrow K_{LL} = 2$

As per ASCE-7, dining rooms \rightarrow NO LIVE LOAD REDUCTION

$$A_{I \text{ Corr}} = 2 \times 6 = 12 \text{ m}^2$$

$A_{I \text{ Corr}} < 37.2 \text{ m}^2 \rightarrow$ No live load reduction

$$W_{u \text{ Din}} = (1.2D + 1.6L) \times \perp d = (1.2(3.75) + 1.6(4.79)) \times 3 = \boxed{36.49 \text{ kN/m}}$$

$$W_{u \text{ Corr}} = (1.2D + 1.6L) \times \perp d = (1.2(3.75) + 1.6(3.38)) \times 1 = \boxed{10.63 \text{ kN/m}}$$

Extra: Approximation of trapezoidal load as a uniformly distributed load

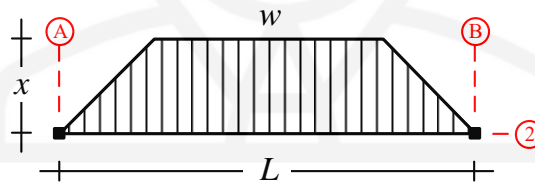

$$w = 36.49 \text{ kN/m}^2 \text{ (Dining room load only), } x = 3 \text{ m}$$

$$\alpha = 1 - \frac{1}{3} \left(\frac{2x}{L} \right)^2 = 1 - \frac{1}{3} \left(\frac{2(3)}{8} \right)^2 = 0.8125$$

$$\beta = 1 - \frac{x}{L} = 1 - \frac{3}{8} = 0.625$$

Equivalent uniformly distributed load for bending moment:

$$w_{eq} = \alpha w = (0.8125)(36.49) = 29.65 \text{ kN/m}$$

Equivalent uniformly distributed load for shear force:

$$w_{eq} = \beta w = (0.625)(36.49) = 22.81 \text{ kN/m}$$

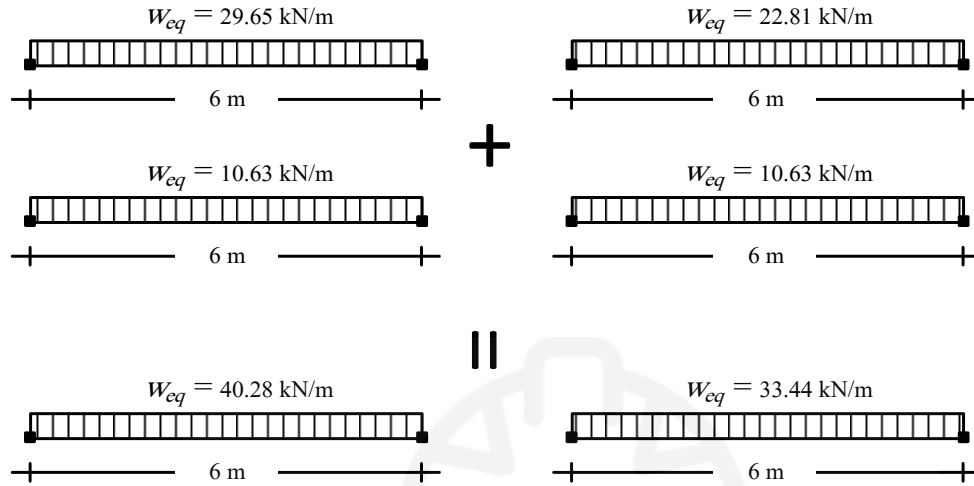

6.4 Problems:

Question:

For the floor plan shown in Figure (1), assuming all slabs are 10 cm thick and:

- Concrete density (ρ_c) = 25 kN/m³
- Mechanical, Electrical, and Piping = 0.5 kN/m²
- Ceiling system = 0.25 kN/m²
- Roofing = 0.28 kN/m²
- Flooring = 0.40 kN/m²

1. Find the “ultimate load” on columns (A1), (D3), and (E5).
2. Find the “ultimate load” on beams (A1–A2), (E5–E6), (C4–E4) and (A6–C6).

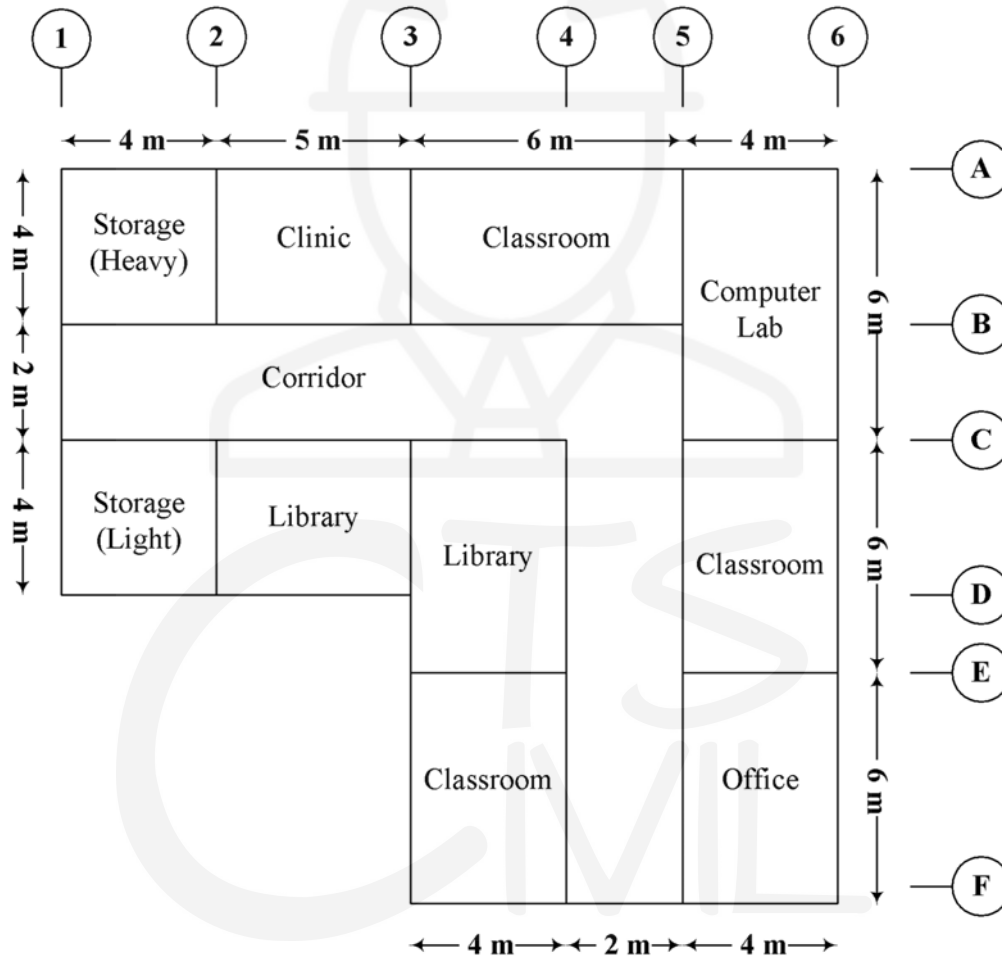
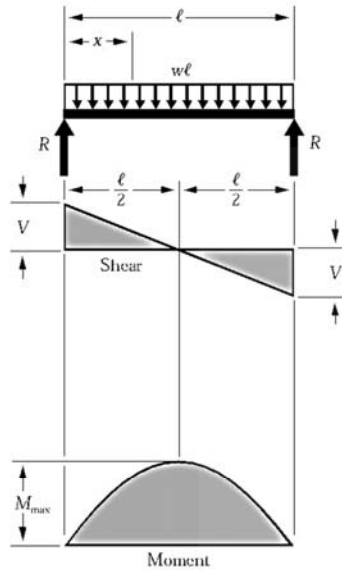

Figure 1: Partial school floor plan (2nd floor)

Chapter (7): Useful Formulas

7.1 Beam Design Formulas with Shear and Moment Diagrams

Figure 1 Simple Beam – Uniformly Distributed Load



$$R = V \dots \dots \dots = \frac{w\ell}{2}$$

$$V_x \dots \dots \dots = w\left(\frac{\ell}{2} - x\right)$$

$$M_{\max} \text{ (at center)} \dots \dots \dots = \frac{w\ell^2}{8}$$

$$M_x \dots \dots \dots = \frac{wx}{2}(\ell - x)$$

$$\Delta_{\max} \text{ (at center)} \dots \dots \dots = \frac{5w\ell^4}{384EI}$$

$$\Delta_x \dots \dots \dots = \frac{wx}{24EI}(\ell^3 - 2\ell x^2 + x^3)$$

Figure 2 Simple Beam – Uniform Load Partially Distributed

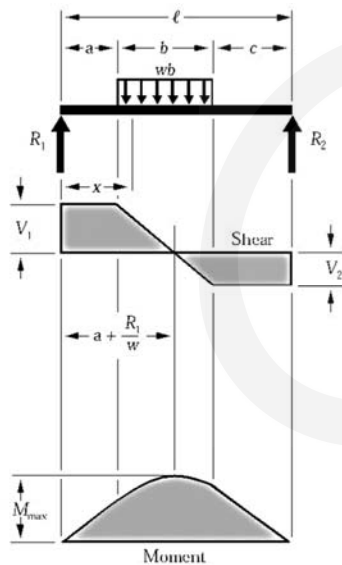

$$R_1 = V_1 \text{ (max when } a < c) \dots \dots = \frac{wb}{2\ell}(2c + b)$$

$$R_2 = V_2 \text{ (max when } a > c) \dots \dots = \frac{wb}{2\ell}(2a + b)$$

$$V_x \text{ (when } x > a \text{ and } < (a + b)) \dots = R_1 - w(x - a)$$

$$M_{\max} \left(\text{at } x = a + \frac{R_1}{w} \right) \dots \dots = R_1 \left(a + \frac{R_1}{2w} \right)$$

$$M_x \text{ (when } x < a) \dots \dots \dots = R_1 x$$

$$M_x \text{ (when } x > a \text{ and } < (a + b)) \dots = R_1 x - \frac{w}{2}(x - a)^2$$

$$M_x \text{ (when } x > (a + b)) \dots \dots \dots = R_2(\ell - x)$$

Figure 3 Simple Beam – Uniform Load Partially Distributed at One End

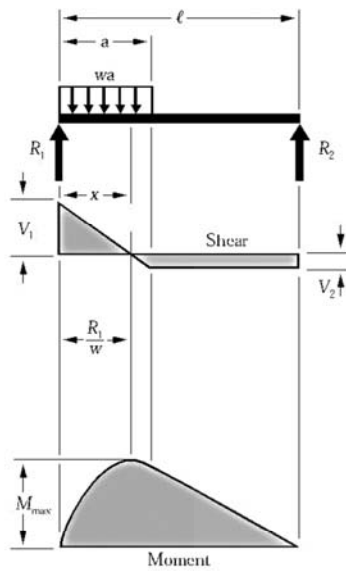

$$R_1 = V_1 \dots \dots \dots = \frac{wa}{2\ell}(2\ell - a)$$

$$R_2 = V_2 \dots \dots \dots = \frac{wa^2}{2\ell}$$

$$V_x \text{ (when } x < a) \dots \dots \dots = R_1 - wx$$

$$M_{\max} \left(\text{at } x = \frac{R_1}{w} \right) \dots \dots \dots = \frac{R_1^2}{2w}$$

$$M_x \text{ (when } x < a) \dots \dots \dots = R_1x - \frac{wx^2}{2}$$

$$M_x \text{ (when } x > a) \dots \dots \dots = R_2(\ell - x)$$

$$\Delta_x \text{ (when } x < a) \dots \dots \dots = \frac{wx}{24 E I \ell} (a^2(2\ell - a)^2 - 2ax^2(2\ell - a) + \ell x^3)$$

$$\Delta_x \text{ (when } x > a) \dots \dots \dots = \frac{wa^2(\ell - x)}{24 E I \ell} (4x\ell - 2x^2 - a^2)$$

Figure 4 Simple Beam – Uniform Load Partially Distributed at Each End

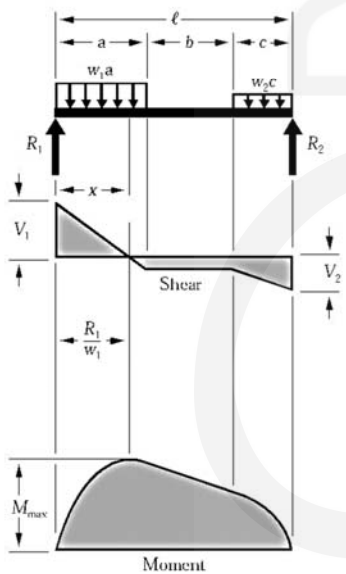

$$R_1 = V_1 \dots \dots \dots = \frac{w_1a(2\ell - a) + w_2c^2}{2\ell}$$

$$R_2 = V_2 \dots \dots \dots = \frac{w_2c(2\ell - c) + w_1a^2}{2\ell}$$

$$V_x \text{ (when } x < a) \dots \dots \dots = R_1 - w_1x$$

$$V_x \text{ (when } x > a \text{ and } < (a + b)) \dots \dots \dots = R_1 - w_1a$$

$$V_x \text{ (when } x > (a + b)) \dots \dots \dots = R_2 - w_2(\ell - x)$$

$$M_{\max} \left(\text{at } x = \frac{R_1}{w_1} \text{ when } R_1 < w_1a \right) \dots \dots \dots = \frac{R_1^2}{2w_1}$$

$$M_{\max} \left(\text{at } x = \ell - \frac{R_2}{w_2} \text{ when } R_2 < w_2c \right) \dots \dots \dots = \frac{R_2^2}{2w_2}$$

$$M_x \text{ (when } x < a) \dots \dots \dots = R_1x - \frac{w_1x^2}{2}$$

$$M_x \text{ (when } x > a \text{ and } < (a + b)) \dots \dots \dots = R_1x - \frac{w_1a}{2}(2x - a)$$

$$M_x \text{ (when } x > (a + b)) \dots \dots \dots = R_2(\ell - x) - \frac{w_2(\ell - x)^2}{2}$$

Figure 5 Simple Beam – Load Increasing Uniformly to One End

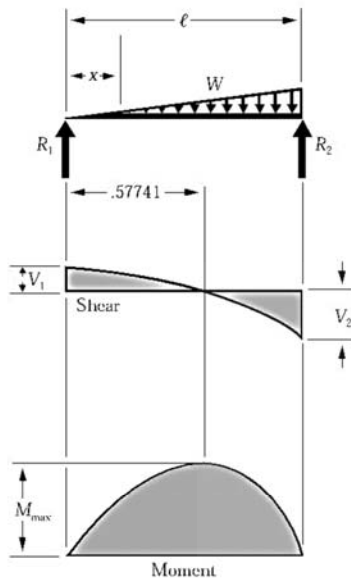

$$R_1 = V_1 \dots \dots \dots = \frac{W}{3}$$

$$R_2 = V_2 \dots \dots \dots = \frac{2W}{3}$$

$$V_x \dots \dots \dots = \frac{W}{3} - \frac{Wx^2}{\ell^2}$$

$$M_{\max} \left(\text{at } x = \frac{\ell}{\sqrt{3}} = .5774\ell \right) \dots \dots = \frac{2W\ell}{9\sqrt{3}} = .1283W\ell$$

$$M_x \dots \dots \dots = \frac{Wx}{3\ell^2} (\ell^2 - x^2)$$

$$\Delta_{\max} \left(\text{at } x = \ell \sqrt{1 - \frac{8}{15}} = .5193\ell \right) \dots = .01304 \frac{W\ell^3}{EI}$$

$$\Delta_x \dots \dots \dots = \frac{Wx}{180EI\ell^2} (3x^4 - 10\ell^2x^2 + 7\ell^4)$$

Figure 6 Simple Beam – Load Increasing Uniformly to Center

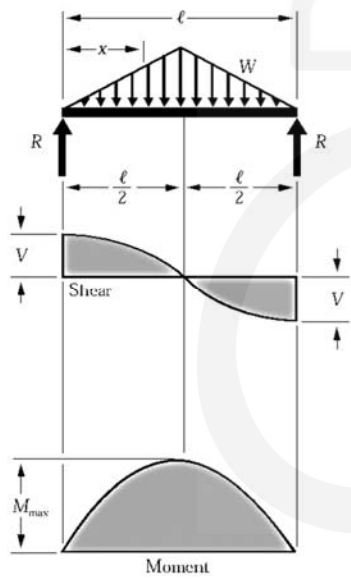

$$R = V \dots \dots \dots = \frac{W}{2}$$

$$V_x \left(\text{when } x < \frac{\ell}{2} \right) \dots \dots \dots = \frac{W}{2\ell^2} (\ell^2 - 4x^2)$$

$$M_{\max} \text{ (at center)} \dots \dots \dots = \frac{W\ell}{6}$$

$$M_x \left(\text{when } x < \frac{\ell}{2} \right) \dots \dots \dots = Wx \left(\frac{1}{2} - \frac{2x^2}{3\ell^2} \right)$$

$$\Delta_{\max} \text{ (at center)} \dots \dots \dots = \frac{W\ell^3}{60EI}$$

$$\Delta_x \dots \dots \dots = \frac{Wx}{480EI\ell^2} (5\ell^2 - 4x^2)^2$$

Figure 7 Simple Beam – Concentrated Load at Center

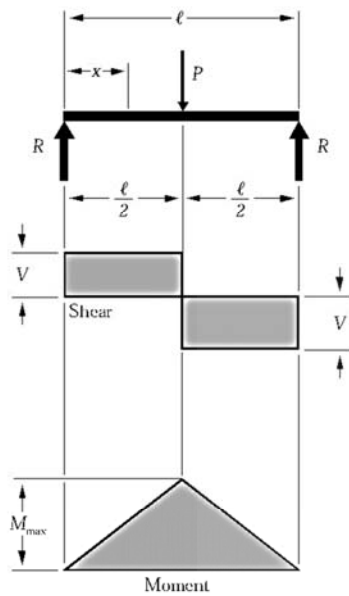

$$R = V \dots \dots \dots = \frac{P}{2}$$

$$M_{\max} \text{ (at point of load)} \dots \dots \dots = \frac{P\ell}{4}$$

$$M_x \text{ (when } x < \frac{\ell}{2} \text{)} \dots \dots \dots = \frac{Px}{2}$$

$$\Delta_{\max} \text{ (at point of load)} \dots \dots \dots = \frac{P\ell^3}{48EI}$$

$$\Delta_x \text{ (when } x < \frac{\ell}{2} \text{)} \dots \dots \dots = \frac{Px}{48EI} (3\ell^2 - 4x^2)$$

Figure 8 Simple Beam – Concentrated Load at Any Point

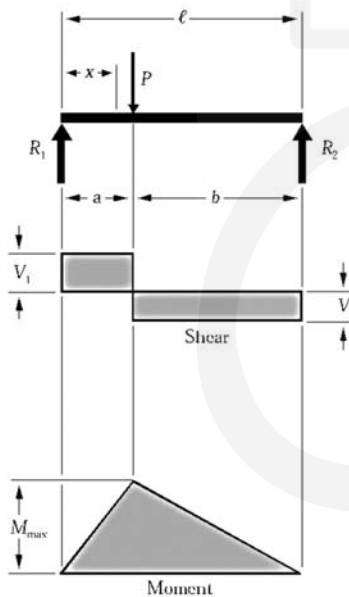

$$R_1 = V_1 \text{ (max when } a < b \text{)} \dots \dots \dots = \frac{Pb}{\ell}$$

$$R_2 = V_2 \text{ (max when } a > b \text{)} \dots \dots \dots = \frac{Pa}{\ell}$$

$$M_{\max} \text{ (at point of load)} \dots \dots \dots = \frac{Pab}{\ell}$$

$$M_x \text{ (when } x < b \text{)} \dots \dots \dots = \frac{Pbx}{\ell}$$

$$\Delta_{\max} \left(\text{at } x = \sqrt{\frac{a(a+2b)}{3}} \text{ when } a > b \right) \dots \dots \dots = \frac{Pab(a+2b)\sqrt{3a(a+2b)}}{27EI\ell}$$

$$\Delta_a \text{ (at point of load)} \dots \dots \dots = \frac{Pa^2b^2}{3EI\ell}$$

$$\Delta_x \text{ (when } x < a \text{)} \dots \dots \dots = \frac{Pbx}{6EI\ell} (\ell^2 - b^2 - x^2)$$

$$\Delta_x \text{ (when } x > a \text{)} \dots \dots \dots = \frac{Pa(\ell-x)}{6EI\ell} (2\ell x - x^2 - a^2)$$

Figure 9 Simple Beam – Two Equal Concentrated Loads Symmetrically Placed

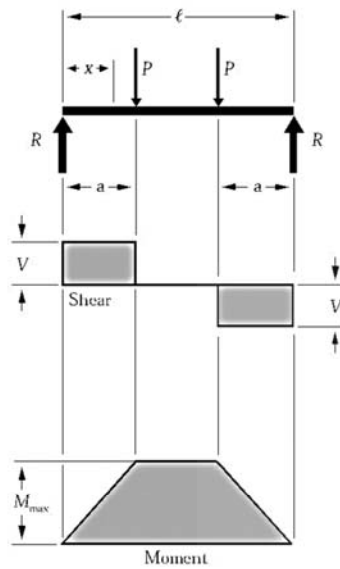

$$R = V \dots \dots \dots = P$$

$$M_{max} \text{ (between loads)} \dots \dots \dots = Pa$$

$$M_x \text{ (when } x < a) \dots \dots \dots = Px$$

$$\Delta_{max} \text{ (at center)} \dots \dots \dots = \frac{Pa}{24EI} (3\ell^2 - 4a^2)$$

$$\Delta_x \text{ (when } x < a) \dots \dots \dots = \frac{Px}{6EI} (3\ell a - 3a^2 - x^2)$$

$$\Delta_x \text{ (when } x > a \text{ and } < (\ell - a)) \dots \dots = \frac{Pa}{6EI} (3\ell x - 3x^2 - a^2)$$

Figure 10 Simple Beam – Two Equal Concentrated Loads Unsymmetrically Placed

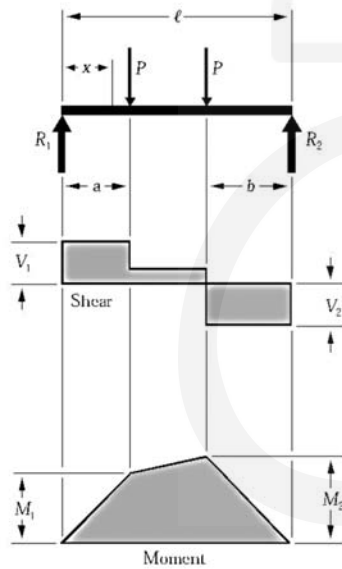

$$R_1 = V_1 \text{ (max when } a < b) \dots \dots \dots = \frac{P}{\ell} (\ell - a + b)$$

$$R_2 = V_2 \text{ (max when } a > b) \dots \dots \dots = \frac{P}{\ell} (\ell - b + a)$$

$$V_x \text{ (when } x > a \text{ and } < (\ell - b)) \dots \dots = \frac{P}{\ell} (b - a)$$

$$M_1 \text{ (max when } a > b) \dots \dots \dots = R_1 a$$

$$M_2 \text{ (max when } a < b) \dots \dots \dots = R_2 b$$

$$M_x \text{ (when } x < a) \dots \dots \dots = R_1 x$$

$$M_x \text{ (when } x > a \text{ and } < (\ell - b)) \dots \dots = R_1 x - P(x - a)$$

Figure 11 Simple Beam – Two Unequal Concentrated Loads Unsymmetrically Placed

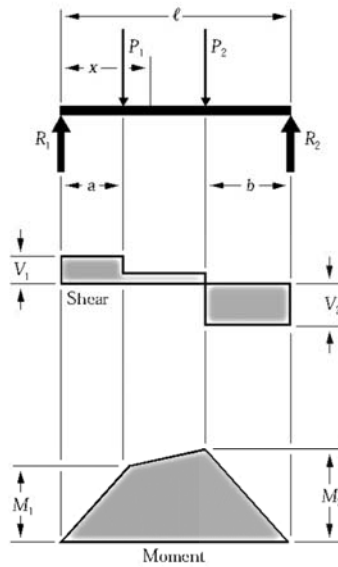

$$R_1 = V_1 \dots \dots \dots = \frac{P_1(\ell - a) + P_2 b}{\ell}$$

$$R_2 = V_2 \dots \dots \dots = \frac{P_1 a + P_2(\ell - b)}{\ell}$$

$$V_x \text{ (when } x > a \text{ and } < (\ell - b)) \dots \dots = R_1 - P_1$$

$$M_1 \text{ (max when } R_1 < P_1) \dots \dots \dots = R_1 a$$

$$M_2 \text{ (max when } R_2 < P_2) \dots \dots \dots = R_2 b$$

$$M_x \text{ (when } x < a) \dots \dots \dots = R_1 x$$

$$M_x \text{ (when } x > a \text{ and } < (\ell - b)) \dots \dots = R_1 x - P_1(x - a)$$

Figure 12 Cantilever Beam – Uniformly Distributed Load

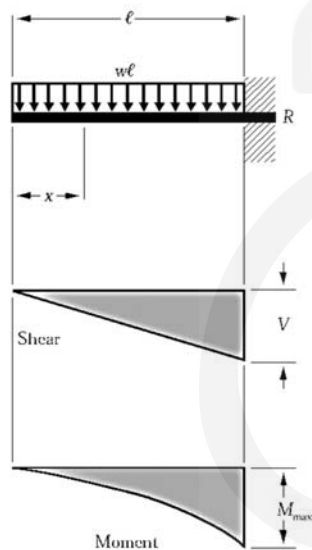

$$R = V \dots \dots \dots = w\ell$$

$$V_x \dots \dots \dots = wx$$

$$M_{\max} \text{ (at fixed end)} \dots \dots \dots = \frac{w\ell^2}{2}$$

$$M_x \dots \dots \dots = \frac{wx^2}{2}$$

$$\Delta_{\max} \text{ (at free end)} \dots \dots \dots = \frac{w\ell^4}{8EI}$$

$$\Delta_x \dots \dots \dots = \frac{w}{24EI} (x^4 - 4\ell^3 x + 3\ell^4)$$

Figure 13 Cantilever Beam – Concentrated Load at Free End

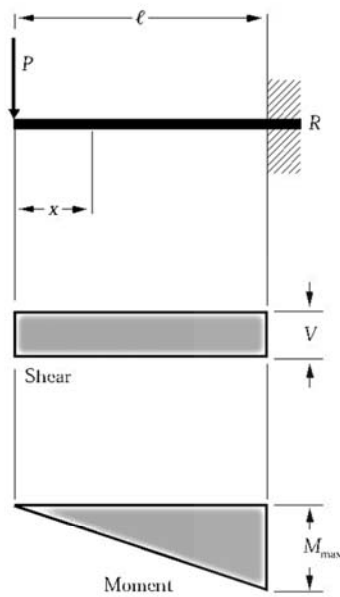

$$R = V \dots \dots \dots = P$$

$$M_{\max} \text{ (at fixed end)} \dots \dots \dots = P\ell$$

$$M_x \dots \dots \dots = Px$$

$$\Delta_{\max} \text{ (at free end)} \dots \dots \dots = \frac{P\ell^3}{3EI}$$

$$\Delta_x \dots \dots \dots = \frac{P}{6EI} (2\ell^3 - 3\ell^2x + x^3)$$

Figure 14 Cantilever Beam – Concentrated Load at Any Point

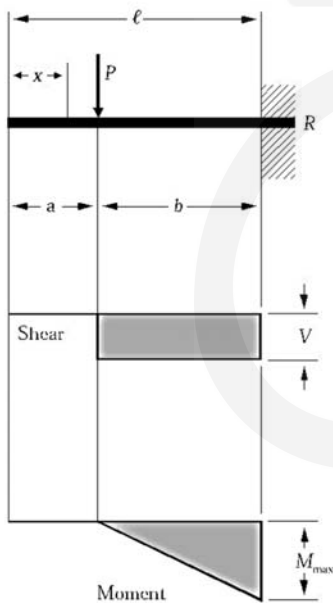

$$R = V \dots \dots \dots = P$$

$$M_{\max} \text{ (at fixed end)} \dots \dots \dots = Pb$$

$$M_x \text{ (when } x > a) \dots \dots \dots = P(x - a)$$

$$\Delta_{\max} \text{ (at free end)} \dots \dots \dots = \frac{Pb^2}{6EI} (3\ell - b)$$

$$\Delta_a \text{ (at point of load)} \dots \dots \dots = \frac{Pb^3}{3EI}$$

$$\Delta_x \text{ (when } x < a) \dots \dots \dots = \frac{Pb^2}{6EI} (3\ell - 3x - b)$$

$$\Delta_x \text{ (when } x > a) \dots \dots \dots = \frac{P(\ell - x)^2}{6EI} (3b - \ell + x)$$

Figure 15 Beam Fixed at One End, Supported at Other – Uniformly Distributed Load

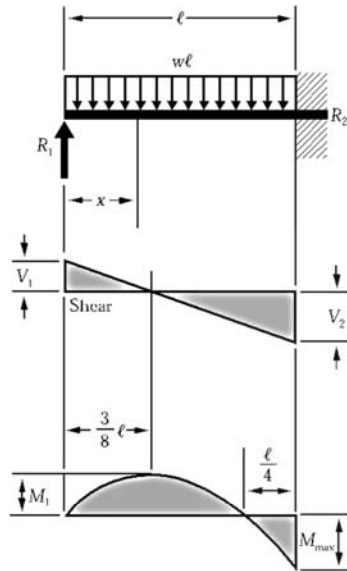

$$\begin{aligned}
 R_1 = V_1 & \dots\dots\dots = \frac{3w\ell}{8} \\
 R_2 = V_2 & \dots\dots\dots = \frac{5w\ell}{8} \\
 V_x & \dots\dots\dots = R_1 - wx \\
 M_{\max} & \dots\dots\dots = \frac{w\ell^2}{8} \\
 M_1 \left(\text{at } x = \frac{3}{8}\ell \right) & \dots\dots\dots = \frac{9}{128}w\ell^2 \\
 M_x & \dots\dots\dots = R_1x - \frac{wx^2}{2} \\
 \Delta_{\max} \left(\text{at } x = \frac{\ell}{16}(1 + \sqrt{33}) = .4215\ell \right) & \dots\dots\dots = \frac{w\ell^4}{185EI} \\
 \Delta_x & \dots\dots\dots = \frac{wx}{48EI}(\ell^3 - 3\ell x^2 + 2x^3)
 \end{aligned}$$

Figure 16 Beam Fixed at One End, Supported at Other – Concentrated Load at Center

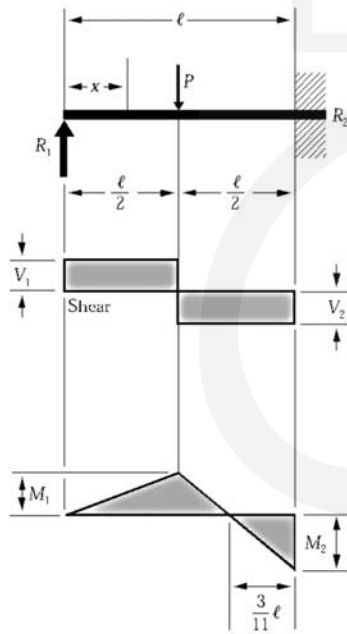

$$\begin{aligned}
 R_1 = V_1 & \dots\dots\dots = \frac{5P}{16} \\
 R_2 = V_2 & \dots\dots\dots = \frac{11P}{16} \\
 M_{\max} \text{ (at fixed end)} & \dots\dots\dots = \frac{3P\ell}{16} \\
 M_1 \text{ (at point of load)} & \dots\dots\dots = \frac{5P\ell}{32} \\
 M_x \left(\text{when } x < \frac{\ell}{2} \right) & \dots\dots\dots = \frac{5Px}{16} \\
 M_x \left(\text{when } x > \frac{\ell}{2} \right) & \dots\dots\dots = P \left(\frac{\ell}{2} - \frac{11x}{16} \right) \\
 \Delta_{\max} \left(\text{at } x = \ell \sqrt{\frac{1}{5}} = .4472\ell \right) & \dots\dots\dots = \frac{P\ell^3}{48EI\sqrt{5}} = .009317 \frac{P\ell^3}{EI} \\
 \Delta_x \text{ (at point of load)} & \dots\dots\dots = \frac{7P\ell^3}{768EI} \\
 \Delta_x \left(\text{when } x < \frac{\ell}{2} \right) & \dots\dots\dots = \frac{Px}{96EI}(3\ell^2 - 5x^2) \\
 \Delta_x \left(\text{when } x > \frac{\ell}{2} \right) & \dots\dots\dots = \frac{P}{96EI}(x - \ell)^2(11x - 2\ell)
 \end{aligned}$$

Figure 17 Beam Fixed at One End, Supported at Other – Concentrated Load at Any Point

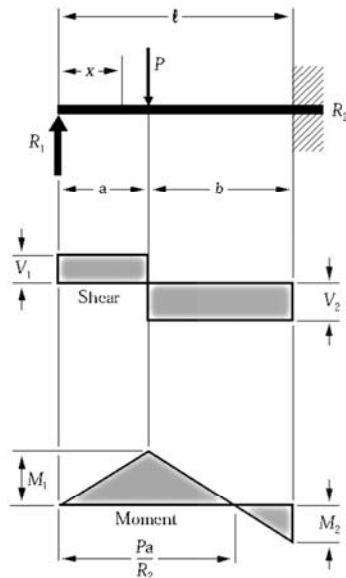

$$R_1 = V_1 \dots \dots \dots = \frac{Pb^2}{2\ell^3}(a + 2\ell)$$

$$R_2 = V_2 \dots \dots \dots = \frac{Pa}{2\ell^3}(3\ell^2 - a^2)$$

$$M_1 \text{ (at point of load)} \dots \dots \dots = R_1 a$$

$$M_2 \text{ (at fixed end)} \dots \dots \dots = \frac{Pab}{2\ell^2}(a + \ell)$$

$$M_x \text{ (when } x < a) \dots \dots \dots = R_1 x$$

$$M_x \text{ (when } x > a) \dots \dots \dots = R_1 x - P(x - a)$$

$$\Delta_{max} \left(\text{when } a < .414\ell \text{ at } x = \ell \frac{\ell^2 + a^2}{3\ell^2 - a^2} \right) = \frac{Pa}{3EI} \frac{(\ell^2 - a^2)^3}{(3\ell^2 - a^2)^2}$$

$$\Delta_{max} \left(\text{when } a > .414\ell \text{ at } x = \ell \sqrt{\frac{a}{2\ell + a}} \right) = \frac{Pab^2}{6EI} \sqrt{\frac{a}{2\ell + a}}$$

$$\Delta_a \text{ (at point of load)} \dots \dots \dots = \frac{Pa^2 b^3}{12EI\ell^3}(3\ell + a)$$

$$\Delta_x \text{ (when } x < a) \dots \dots \dots = \frac{Pb^2 x}{12EI\ell^3}(3a\ell^2 - 2\ell x^2 - ax^2)$$

$$\Delta_x \text{ (when } x > a) \dots \dots \dots = \frac{Pa}{12EI\ell^3}(\ell - x)^2(3\ell^2 x - a^2 x - 2a^2 \ell)$$

Figure 18 Beam Overhanging One Support – Uniformly Distributed Load

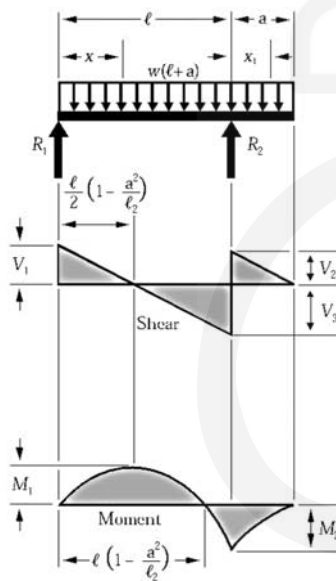

$$R_1 = V_1 \dots \dots \dots = \frac{w}{2\ell}(\ell^2 - a^2)$$

$$R_2 = V_2 + V_3 \dots \dots \dots = \frac{w}{2\ell}(\ell + a)^2$$

$$V_2 \dots \dots \dots = wa$$

$$V_3 \dots \dots \dots = \frac{w}{2\ell}(\ell^2 + a^2)$$

$$V_x \text{ (between supports)} \dots \dots = R_1 - wx$$

$$V_{x_1} \text{ (for overhang)} \dots \dots = w(a - x_1)$$

$$M_1 \left(\text{at } x = \frac{\ell}{2} \left[1 - \frac{a^2}{\ell^2} \right] \right) \dots \dots = \frac{w}{8\ell^2}(\ell + a)^2(\ell - a)^2$$

$$M_2 \text{ (at } R_2) \dots \dots \dots = \frac{wa^2}{2}$$

$$M_x \text{ (between supports)} \dots \dots = \frac{wx}{2\ell}(\ell^2 - a^2 - x\ell)$$

$$M_{x_1} \text{ (for overhang)} \dots \dots = \frac{w}{2}(a - x_1)^2$$

$$\Delta_x \text{ (between supports)} \dots \dots = \frac{wx}{24EI\ell}(\ell^4 - 2\ell^2 x^2 + \ell x^3 - 2a^2 \ell^2 + 2a^2 x^2)$$

$$\Delta_{x_1} \text{ (for overhang)} \dots \dots = \frac{wx_1}{24EI}(4a^2 \ell - \ell^3 + 6a^2 x_1 - 4ax_1^2 + x_1^3)$$

Figure 19 Beam Overhanging One Support – Uniformly Distributed Load on Overhang

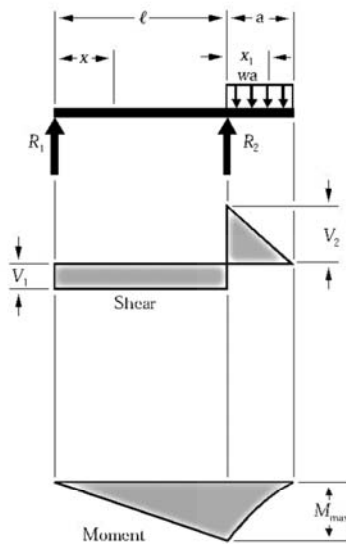

$$R_1 = V_1 \dots \dots \dots = \frac{wa^2}{2\ell}$$

$$R_2 = V_1 + V_2 \dots \dots \dots = \frac{wa}{2\ell}(2\ell + a)$$

$$V_2 \dots \dots \dots = wa$$

$$V_{x_1} \text{ (for overhang)} \dots \dots \dots = w(a - x_1)$$

$$M_{\max} \text{ (at } R_2) \dots \dots \dots = \frac{wa^2}{2}$$

$$M_x \text{ (between supports)} \dots \dots \dots = \frac{wa^2x}{2\ell}$$

$$M_{x_1} \text{ (for overhang)} \dots \dots \dots = \frac{w}{2}(a - x_1)^2$$

$$\Delta_{\max} \left(\text{between supports at } x = \frac{\ell}{\sqrt{3}} \right) = \frac{wa^2\ell^2}{18\sqrt{3}EI} = .03208 \frac{wa^2\ell^2}{EI}$$

$$\Delta_{\max} \text{ (for overhang at } x_1 = a) \dots \dots = \frac{wa^3}{24EI}(4\ell + 3a)$$

$$\Delta_x \text{ (between supports)} \dots \dots \dots = \frac{wa^2x}{12EI\ell}(\ell^2 - x^2)$$

$$\Delta_{x_1} \text{ (for overhang)} \dots \dots \dots = \frac{wx_1}{24EI}(4a^2\ell + 6a^2x_1 - 4ax_1^2 + x_1^3)$$

Figure 20 Beam Overhanging One Support – Concentrated Load at End of Overhang

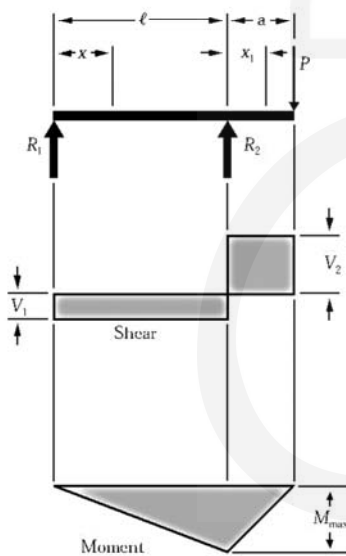

$$R_1 = V_1 \dots \dots \dots = \frac{Pa}{\ell}$$

$$R_2 = V_1 + V_2 \dots \dots \dots = \frac{P}{\ell}(\ell + a)$$

$$V_2 \dots \dots \dots = P$$

$$M_{\max} \text{ (at } R_2) \dots \dots \dots = Pa$$

$$M_x \text{ (between supports)} \dots \dots \dots = \frac{Pax}{\ell}$$

$$M_{x_1} \text{ (for overhang)} \dots \dots \dots = P(a - x_1)$$

$$\Delta_{\max} \left(\text{between supports at } x = \frac{\ell}{\sqrt{3}} \right) = \frac{Pa\ell^2}{9\sqrt{3}EI} = .06415 \frac{Pa\ell^2}{EI}$$

$$\Delta_{\max} \text{ (for overhang at } x_1 = a) \dots \dots = \frac{Pa^2}{3EI}(\ell + a)$$

$$\Delta_x \text{ (between supports)} \dots \dots \dots = \frac{Pax}{6EI\ell}(\ell^2 - x^2)$$

$$\Delta_{x_1} \text{ (for overhang)} \dots \dots \dots = \frac{Px_1}{6EI}(2a\ell + 3ax_1 - x_1^2)$$

Figure 21 Beam Overhanging One Support – Concentrated Load at Any Point Between Supports

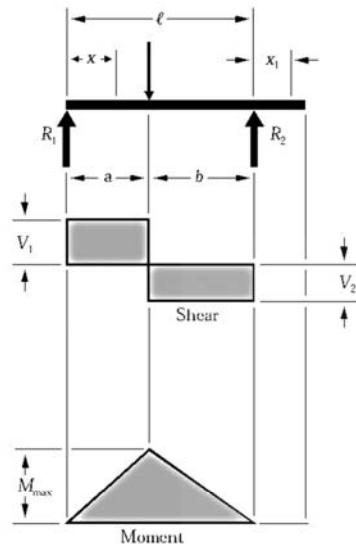

$$R_1 = V_1 \text{ (max when } a < b) \dots \dots \dots = \frac{Pb}{\ell}$$

$$R_2 = V_2 \text{ (max when } a > b) \dots \dots \dots = \frac{Pa}{\ell}$$

$$M_{\max} \text{ (at point of load)} \dots \dots \dots = \frac{Pab}{\ell}$$

$$M_x \text{ (when } x < a) \dots \dots \dots = \frac{Pbx}{\ell}$$

$$\Delta_{\max} \left(\text{at } x = \sqrt{\frac{a(a+2b)}{3}} \text{ when } a > b \right) \dots \dots \dots = \frac{Pab(a+2b)\sqrt{3a(a+2b)}}{27EI\ell}$$

$$\Delta_a \text{ (at point of load)} \dots \dots \dots = \frac{Pa^2b^2}{3EI\ell}$$

$$\Delta_x \text{ (when } x < a) \dots \dots \dots = \frac{Pbx}{6EI} (\ell^2 - b^2 - x^2)$$

$$\Delta_x \text{ (when } x > a) \dots \dots \dots = \frac{Pa(\ell - x)}{6EI} (2\ell x - x^2 - a^2)$$

$$\Delta_{x_1} \dots \dots \dots = \frac{Pabx_1}{6EI} (\ell + a)$$

Figure 22 Beam Overhanging Both Supports – Unequal Overhangs – Uniformly Distributed Load

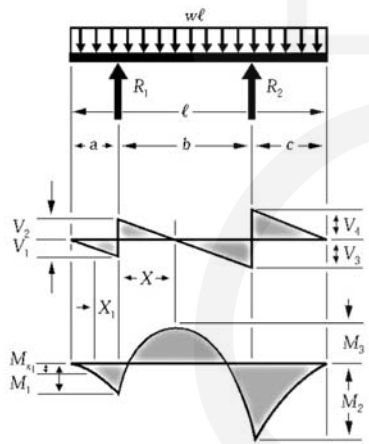

$$R_1 \dots \dots \dots = \frac{w\ell(\ell - 2c)}{2b}$$

$$R_2 \dots \dots \dots = \frac{w\ell(\ell - 2a)}{2b}$$

$$V_1 \dots \dots \dots = wa$$

$$V_2 \dots \dots \dots = R_1 - V_1$$

$$V_3 \dots \dots \dots = R_2 - V_4$$

$$V_4 \dots \dots \dots = wc$$

$$V_{x_1} \dots \dots \dots = V_1 - wx_1$$

$$V_x \text{ (when } x < \ell) \dots \dots \dots = R_1 - w(a + x_1)$$

$$V_m \text{ (when } a < c) \dots \dots \dots = R_2 - wc$$

$$M_1 \dots \dots \dots = -\frac{wa^2}{2}$$

$$M_2 \dots \dots \dots = -\frac{wc^2}{2}$$

$$M_3 \dots \dots \dots = R_1 \left(\frac{R_1}{2w} - a \right)$$

$$M_x \left(\text{max when } x = \frac{R_1}{w} - a \right) \dots \dots \dots = R_1 x - \frac{w(a+x)^2}{2}$$



Figure 23 Beam Fixed at Both Ends – Uniformly Distributed Load

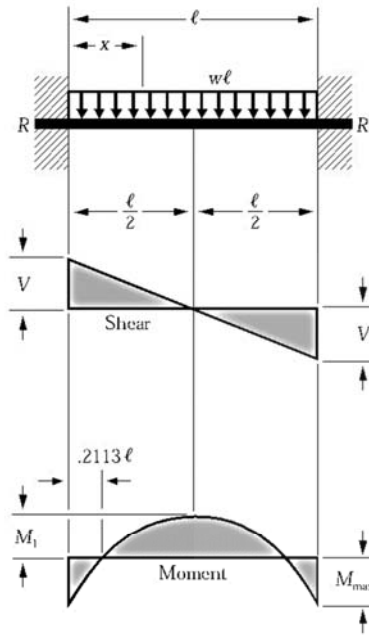

$$R = V \dots\dots\dots = \frac{wl}{2}$$

$$V_x \dots\dots\dots = w\left(\frac{\ell}{2} - x\right)$$

$$M_{\max} \text{ (at ends)} \dots\dots\dots = \frac{wl^2}{12}$$

$$M_l \text{ (at center)} \dots\dots\dots = \frac{wl^2}{24}$$

$$M_x \dots\dots\dots = \frac{w}{12}(6\ell x - \ell^2 - 6x^2)$$

$$\Delta_{\max} \text{ (at center)} \dots\dots\dots = \frac{wl^4}{384EI}$$

$$\Delta_x \dots\dots\dots = \frac{wx^2}{24EI}(\ell - x)^2$$

Figure 24 Beam Fixed at Both Ends – Concentrated Load at Center

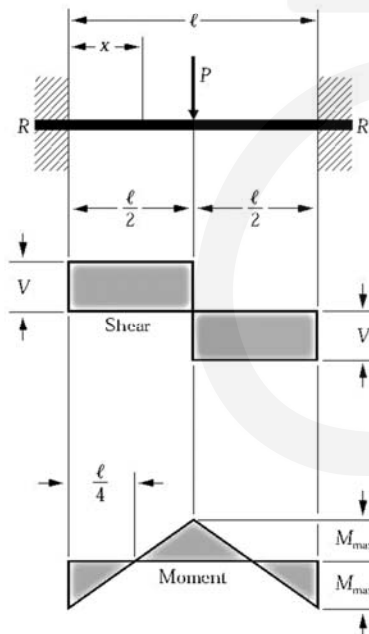

$$R = V \dots\dots\dots = \frac{P}{2}$$

$$M_{\max} \text{ (at center and ends)} \dots\dots\dots = \frac{P\ell}{8}$$

$$M_x \left(\text{when } x < \frac{\ell}{2} \right) \dots\dots\dots = \frac{P}{8}(4x - \ell)$$

$$\Delta_{\max} \text{ (at center)} \dots\dots\dots = \frac{P\ell^3}{192EI}$$

$$\Delta_x \left(\text{when } x < \frac{\ell}{2} \right) \dots\dots\dots = \frac{Px^2}{48EI}(3\ell - 4x)$$



Figure 25 Beam Fixed at Both Ends – Concentrated Load at Any Point

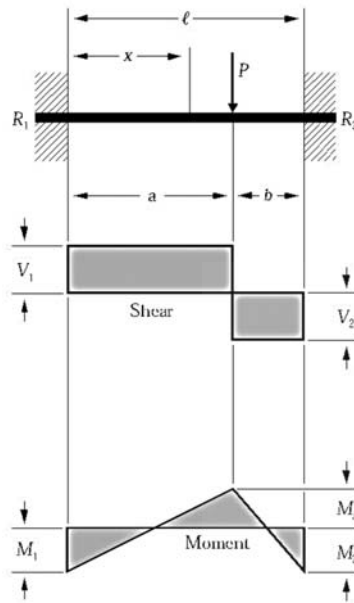

$$R_1 = V_1 \text{ (max when } a < b) \dots \dots \dots = \frac{Pb^2}{\ell^3} (3a + b)$$

$$R_2 = V_2 \text{ (max when } a > b) \dots \dots \dots = \frac{Pa^2}{\ell^3} (a + 3b)$$

$$M_1 \text{ (max when } a < b) \dots \dots \dots = \frac{Pab^2}{\ell^2}$$

$$M_2 \text{ (max when } a > b) \dots \dots \dots = \frac{Pa^2b}{\ell^2}$$

$$M_a \text{ (at point of load) } \dots \dots \dots = \frac{2Pa^2b^2}{\ell^3}$$

$$M_x \text{ (when } x < a) \dots \dots \dots = R_1x - \frac{Pab^2}{\ell^2}$$

$$\Delta_{\max} \left(\text{when } a > b \text{ at } x = \frac{2a\ell}{3a + b} \right) \dots \dots = \frac{2Pa^3b^2}{3EI(3a + b)^2}$$

$$\Delta_a \text{ (at point of load) } \dots \dots \dots = \frac{Pa^3b^3}{3EI\ell^3}$$

$$\Delta_x \text{ (when } x < a) \dots \dots \dots = \frac{Pb^2x^2}{6EI\ell^3} (3a\ell - 3ax - bx)$$

Figure 26 Continuous Beam – Two Equal Spans – Uniform Load on One Span

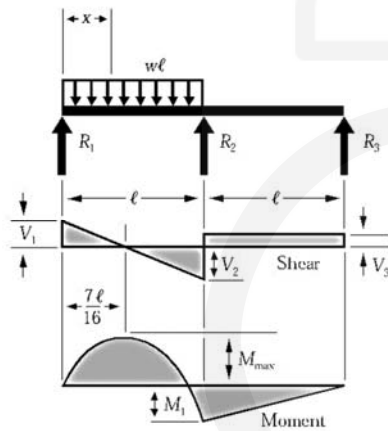

$$R_1 = V_1 \dots \dots \dots = \frac{7}{16} w\ell$$

$$R_2 = V_2 + V_3 \dots \dots \dots = \frac{5}{8} w\ell$$

$$R_3 = V_3 \dots \dots \dots = -\frac{1}{16} w\ell$$

$$V_2 \dots \dots \dots = \frac{9}{16} w\ell$$

$$M_{\max} \left(\text{at } x = \frac{7}{16} \ell \right) \dots \dots \dots = \frac{49}{512} w\ell^2$$

$$M_1 \text{ (at support } R_2) \dots \dots \dots = \frac{1}{16} w\ell^2$$

$$M_x \text{ (when } x < \ell) \dots \dots \dots = \frac{wx}{16} (7\ell - 8x)$$

Figure 27 Continuous Beam – Two Equal Spans – Concentrated Load at Center of One Span

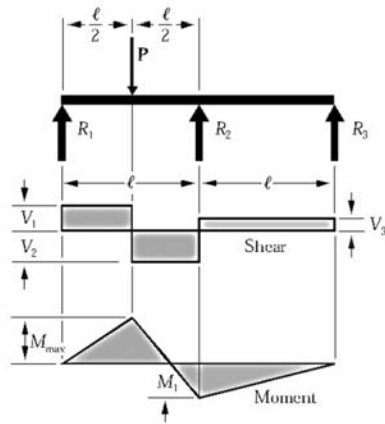

$$R_1 = V_1 \dots\dots\dots = \frac{13}{32} P$$

$$R_2 = V_2 + V_3 \dots\dots\dots = \frac{11}{16} P$$

$$R_3 = V_3 \dots\dots\dots = -\frac{3}{32} P$$

$$V_2 \dots\dots\dots = \frac{19}{32} P$$

$$M_{\max} \text{ (at point of load)} \dots\dots\dots = \frac{13}{64} P\ell$$

$$M_1 \text{ (at support } R_2) \dots\dots\dots = \frac{3}{32} P\ell$$

Figure 28 Continuous Beam – Two Equal Spans – Concentrated Load at Any Point

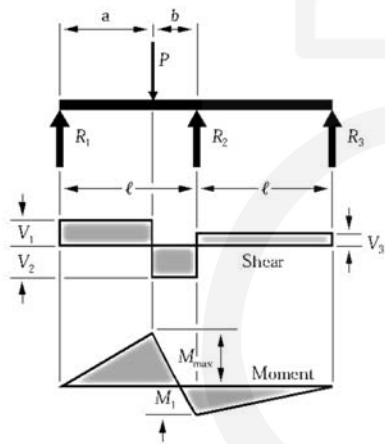

$$R_1 = V_1 \dots\dots\dots = \frac{Pb}{4\ell^3} (4\ell^2 - a(\ell + a))$$

$$R_2 = V_2 + V_3 \dots\dots\dots = \frac{Pa}{2\ell^3} (2\ell^2 + b(\ell + a))$$

$$R_3 = V_3 \dots\dots\dots = -\frac{Pab}{4\ell^3} (\ell + a)$$

$$V_2 \dots\dots\dots = \frac{Pa}{4\ell^3} (4\ell^2 + b(\ell + a))$$

$$M_{\max} \text{ (at point of load)} \dots\dots\dots = \frac{Pab}{4\ell^3} (4\ell^2 - a(\ell + a))$$

$$M_1 \text{ (at support } R_2) \dots\dots\dots = \frac{Pab}{4\ell^2} (\ell + a)$$

Figure 29 Continuous Beam – Two Equal Spans – Uniformly Distributed Load

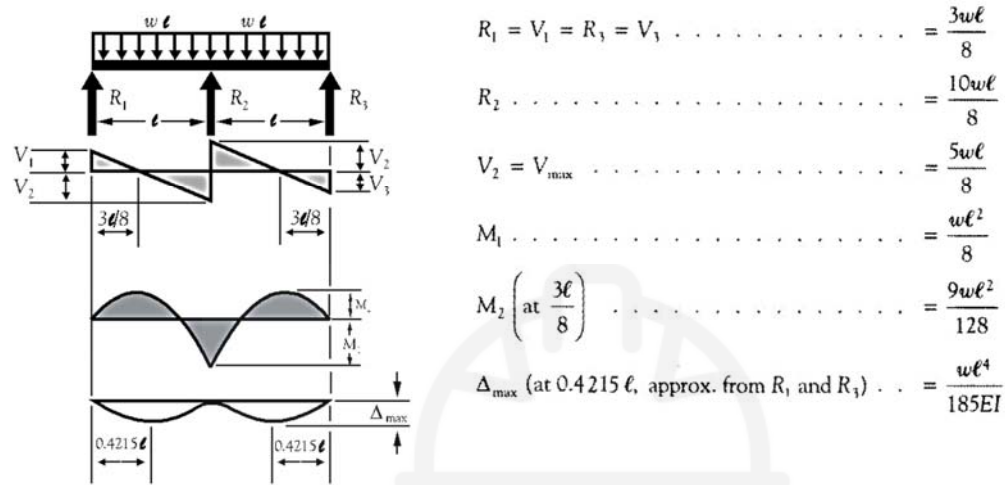

Figure 30 Continuous Beam – Two Equal Spans – Two Equal Concentrated Loads Symmetrically Placed

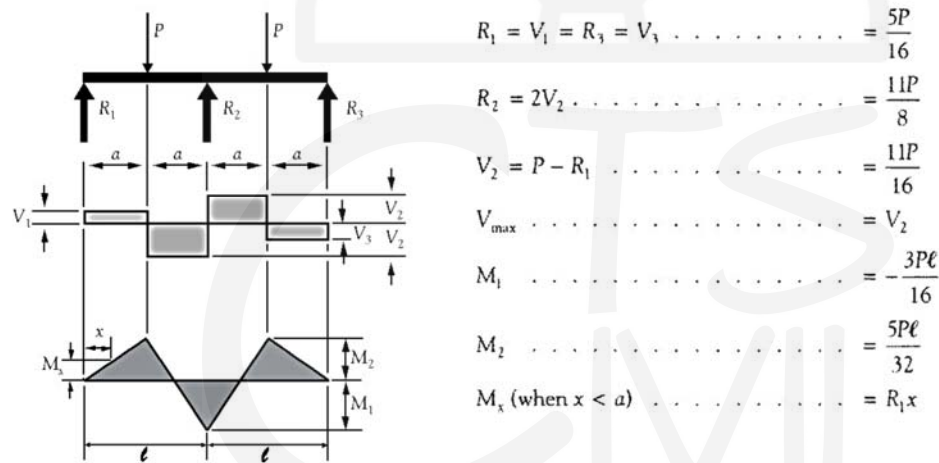
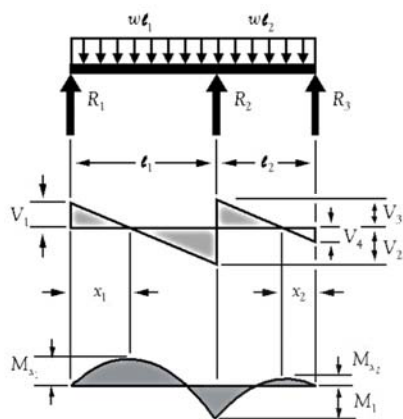
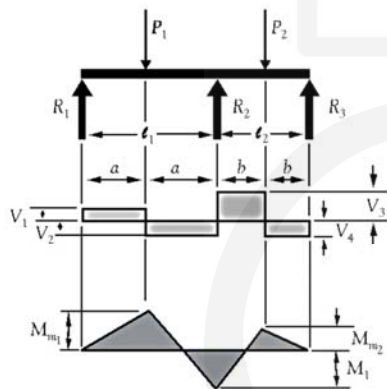

Figure 31 Continuous Beam – Two Unequal Spans – Uniformly Distributed Load



$$\begin{aligned}
 R_1 & \dots \dots \dots = \frac{M_1}{\ell_1} + \frac{w\ell_1}{2} \\
 R_2 & \dots \dots \dots = w\ell_1 + w\ell_2 - R_1 - R_3 \\
 R_3 = V_4 & \dots \dots \dots = \frac{M_1}{\ell_2} + \frac{w\ell_2}{2} \\
 V_1 & \dots \dots \dots = R_1 \\
 V_2 & \dots \dots \dots = w\ell_1 - R_1 \\
 V_3 & \dots \dots \dots = w\ell_2 - R_3 \\
 V_4 & \dots \dots \dots = R_3 \\
 M_1 & \dots \dots \dots = -\frac{w\ell_2^3 + w\ell_1^3}{8(\ell_1 + \ell_2)} \\
 M_{x_1} \left(\text{when } x_1 = \frac{R_1}{w} \right) & \dots \dots \dots = R_1 x_1 - \frac{w x_1^2}{2} \\
 M_{x_2} \left(\text{when } x_2 = \frac{R_3}{w} \right) & \dots \dots \dots = R_3 x_2 - \frac{w x_2^2}{2}
 \end{aligned}$$

Figure 32 Continuous Beam – Two Unequal Spans – Concentrated Load on Each Span Symmetrically Placed





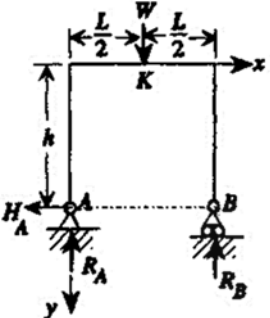
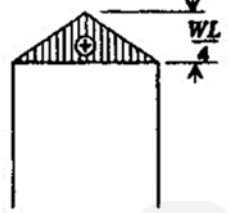
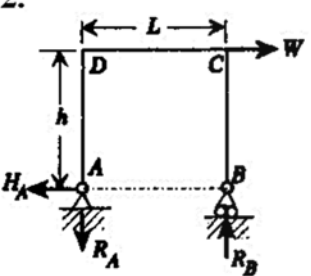
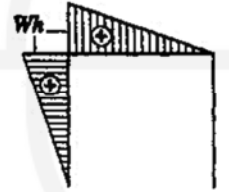
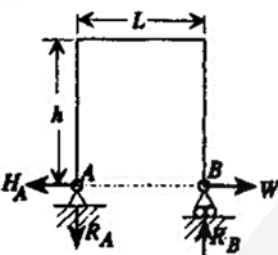
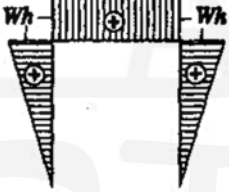
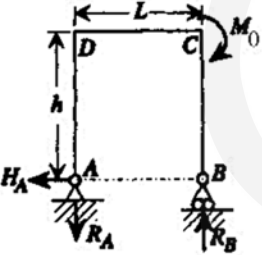
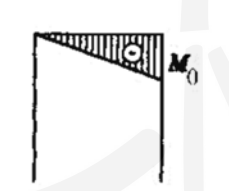

$$\begin{aligned}
 R_1 & \dots \dots \dots = \frac{M_1}{\ell_1} + \frac{P_1}{2} \\
 R_2 & \dots \dots \dots = P_1 + P_2 - R_1 - R_3 \\
 R_3 & \dots \dots \dots = \frac{M_1}{\ell_2} + \frac{P_2}{2} \\
 V_1 & \dots \dots \dots = R_1 \\
 V_2 & \dots \dots \dots = P_1 - R_1 \\
 V_3 & \dots \dots \dots = P_2 - R_3 \\
 V_4 & \dots \dots \dots = R_3 \\
 M_1 & \dots \dots \dots = -\frac{3}{16} \left(\frac{P_1 \ell_1^2 + P_2 \ell_2^2}{\ell_1 + \ell_2} \right) \\
 M_{m_1} & \dots \dots \dots = R_1 a \\
 M_{m_2} & \dots \dots \dots = R_3 b
 \end{aligned}$$

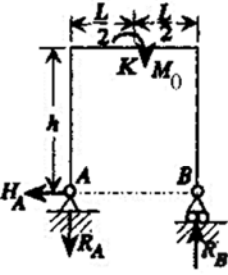
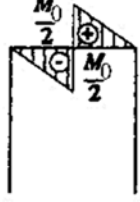
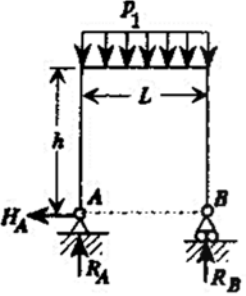
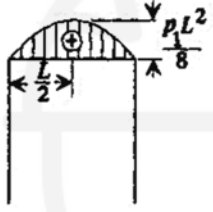
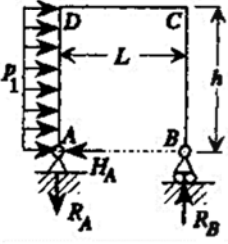
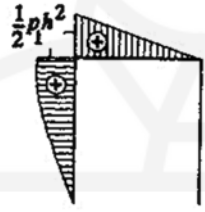
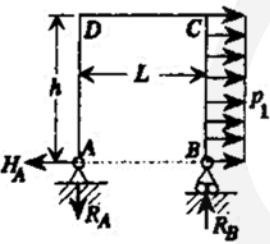
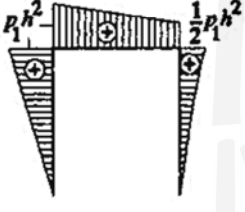
7.2 Bending Moment Diagrams and Equations for Frames

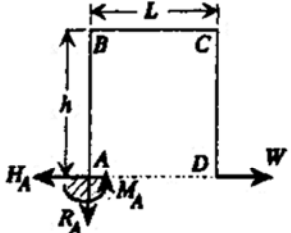
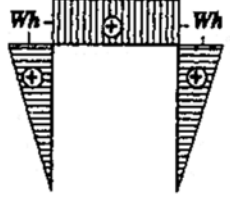
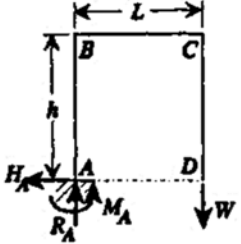
Configuration	Moment Diagram	Important Values
<p>1.</p> 		$H_A = 0$ $R_A = R_B = \frac{1}{2}W$ $v_{Bx} = \frac{WhL^2}{8EI}$ $M_{\max} = \frac{1}{4}WL$ at point K
<p>2.</p> 		$H_A = W$ $R_A = R_B = W \frac{h}{L}$ $v_{Bx} = \frac{Wh^2}{6EI}(3L + 2h)$ $v_{Cy} = 0$ $v_{Cx} = \frac{Wh^2}{3EI}(L + h)$ $M_{\max} = Wh$ at point D
<p>3.</p> 		$H_A = W$ $R_A = R_B = 0$ $v_{Bx} = \frac{Wh^2}{3EI}(3L + 2h)$ $M_{\max} = Wh$
<p>4.</p> 		$H_A = 0$ $R_A = R_B = \frac{M_0}{L}$ $v_{Bx} = \frac{M_0hL}{2EI}$ $M_{\max} = M_0$ at point C

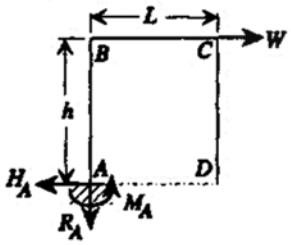
Configuration	Moment Diagram	Important Values
<p>5.</p> 		$H_A = 0 \quad R_A = R_B = \frac{M_0}{L}$ $\theta_K = \frac{M_0 L}{12EI}$ $M_{\max} = \frac{1}{2} M_0 \quad \text{at point } K$
<p>6.</p> 		$H_A = 0 \quad R_A = R_B = \frac{1}{2} p_1 L$ $v_{bx} = \frac{p_1 h L^3}{12EI}$ $M_{\max} = \frac{1}{8} p_1 L^2 \quad \text{at } x = \frac{1}{2} L$
<p>7.</p> 		$H_A = p_1 h \quad R_A = R_B = \frac{p_1 h^2}{2L}$ $v_{Bx} = \frac{p_1 h^3}{24EI} (6L + 5h)$ $M_{\max} = \frac{1}{2} p_1 h^2 \quad \text{at point } D$
<p>8.</p> 		$H_A = p_1 h \quad R_A = R_B = \frac{p_1 h^2}{2L}$ $v_{Bx} = \frac{p_1 h^3}{24EI} (18L + 11h)$ $M_{\max} = p_1 h^2 \quad \text{at point } D$

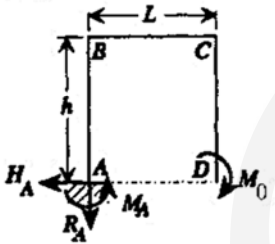
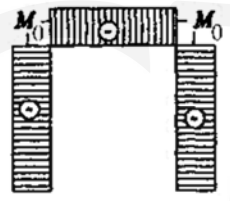
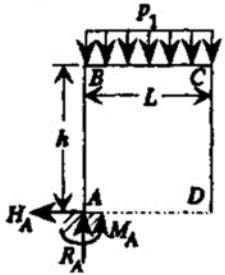
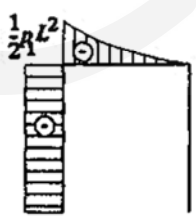
Configuration	Moment Diagram	Important Values
<p>9.</p> 		$H_A = W \quad R_A = 0 \quad M_A = 0$ $v_{Dx} = \frac{Wh^2}{3EI}(3L + 4h)$ $v_{Dy} = -\frac{WhL}{2EI}(L + h)$ $M_{\max} = Wh \quad \text{at points } B, C$
<p>10.</p> 		$H_A = 0 \quad R_A = W \quad M_A = WL$ $v_{Dx} = -\frac{WhL}{2EI}(L + 2h)$ $v_{Dy} = \frac{WL^2}{3EI}(L + 3h)$ $M_{\max} = WL$
<p>11.</p> 		$H_A = W \quad R_A = 0 \quad M_A = Wh$ $v_{Dx} = -\frac{Wh^3}{2EI} \quad v_{Dy} = \frac{WLh^2}{2EI}$ $v_{Cx} = \frac{Wh^3}{3EI} \quad v_{Cy} = \frac{WLh^2}{2EI}$ $M_{\max} = Wh \quad \text{at point } A$
<p>12.</p> 		$H_A = 0 \quad R_A = 0 \quad M_A = M_0$ $v_{Dx} = \frac{M_0h}{EI}(L + 3h)$ $v_{Dy} = -\frac{M_0L}{2EI}(L + 2h)$ $\theta_D = \frac{M_0}{EI}(L + 2h) \quad M_{\max} = M_0$
<p>13.</p> 		$H_A = 0 \quad R_A = p_1L$ $M_A = \frac{1}{2}p_1L^2$ $v_{Dx} = -\frac{p_1L^2h}{6EI}(L + 3h)$ $v_{Dy} = \frac{p_1L^3}{8EI}(L + 4h)$ $M_{\max} = \frac{1}{2}p_1L^2$

7.3 Geometric Properties of Line and Area Elements:

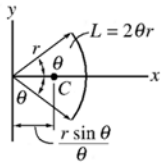
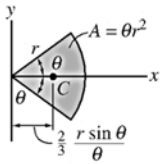
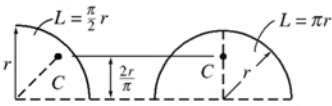
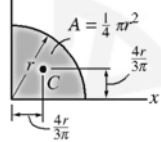
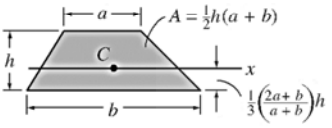
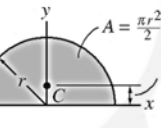
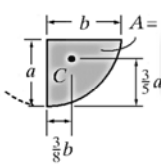
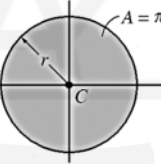
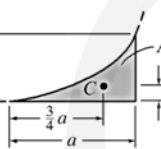
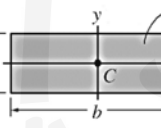
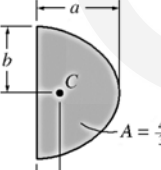
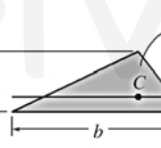
Centroid Location	Centroid Location	Area Moment of Inertia
 <p>Circular arc segment</p>	 <p>Circular sector area</p>	$I_x = \frac{1}{4} r^4 (\theta - \frac{1}{2} \sin 2\theta)$ $I_y = \frac{1}{4} r^4 (\theta + \frac{1}{2} \sin 2\theta)$
 <p>Quarter and semicircle arcs</p>	 <p>Quarter circle area</p>	$I_x = \frac{1}{16} \pi r^4$ $I_y = \frac{1}{16} \pi r^4$
 <p>Trapezoidal area</p>	 <p>Semicircular area</p>	$I_x = \frac{1}{8} \pi r^4$ $I_y = \frac{1}{8} \pi r^4$
 <p>Semiparabolic area</p>	 <p>Circular area</p>	$I_x = \frac{1}{4} \pi r^4$ $I_y = \frac{1}{4} \pi r^4$
 <p>Exparabolic area</p>	 <p>Rectangular area</p>	$I_x = \frac{1}{12} b h^3$ $I_y = \frac{1}{12} h b^3$
 <p>Parabolic area</p>	 <p>Triangular area</p>	$I_x = \frac{1}{36} b h^3$

Square



Perimeter: $P = 4a$

Area: $A = a^2$

Rectangle

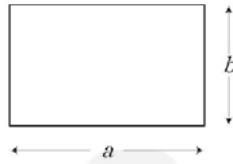

Perimeter: $P = 2(a+b)$

Area: $A = ab$

Trapezoid

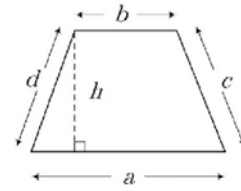

Perimeter: $P = a+b+c+d$

Area: $A = \left(\frac{a+b}{2}\right)h$

Parallelogram

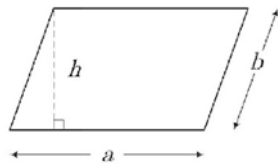

Perimeter: $P = 2(a+b)$

Area: $A = ah$

Circle

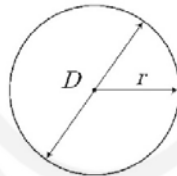

Perimeter: $P = 2\pi r = \pi D$

Area: $A = \pi r^2 = \frac{\pi D^2}{4}$

Circular Sector

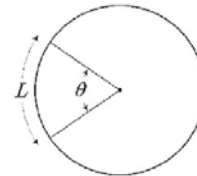

Arch Length: $L = \frac{\pi r \theta}{180^\circ}$

Sector Area: $A = \frac{\pi r^2 \theta}{360^\circ}$

Circular Ring

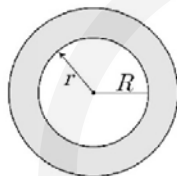

Area: $A = \pi(R^2 - r^2)$

Triangle

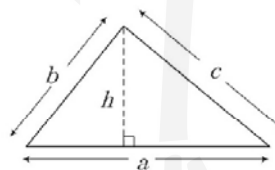

Perimeter: $P = a+b+c$

Area: $A = \frac{ah}{2}$

Right Triangle

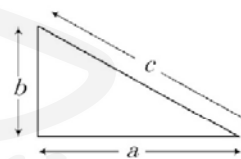

Perimeter: $P = a+b+c$

Area: $A = \frac{ah}{2}$

Pythagorean theorem:

$$c^2 = a^2 + b^2$$

Cube

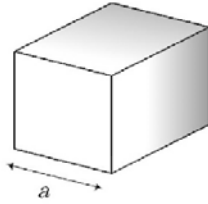

Surface Area: $A = 6a^2$

Volume: $V = a^3$

Rectangular Solid

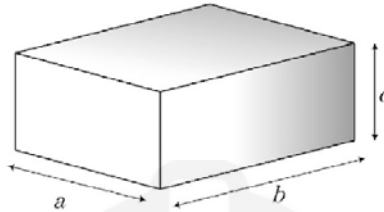

Area: $A = 2(ab + ac + bc)$

Volume: $V = abc$

Sphere

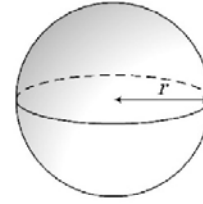

Surface Area:

$$A = 4\pi r^2$$

Volume:

$$V = \frac{4\pi r^3}{3}$$

Cylinder

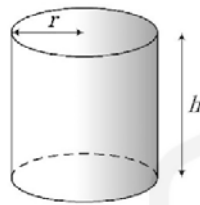

Surface Area:

$$A = 2\pi r(r + h)$$

Volume: $V = \pi r^2 h$

Right Cone

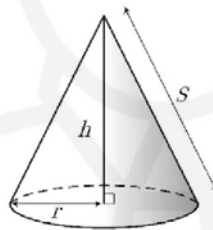

Surface Area:

$$A = \pi r(r + s)$$

$$s = \sqrt{r^2 + h^2}$$

Volume: $V = \frac{\pi r^2 h}{3}$

Frustum of a Cone

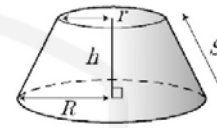

Area:

$$A = \pi \left[Q(R - r) + (R^2 - r^2) + RS \right]$$

$$Q = \sqrt{r^2 + \left(\frac{Hr}{R - r} \right)^2}$$

$$S = \sqrt{(R - r)^2 + H^2}$$

Volume: $V = \frac{\pi h}{3}(r^2 + rR + R^2)$

7.4 Center of Gravity and Mass Moment of Inertia of Homogenous Solids:

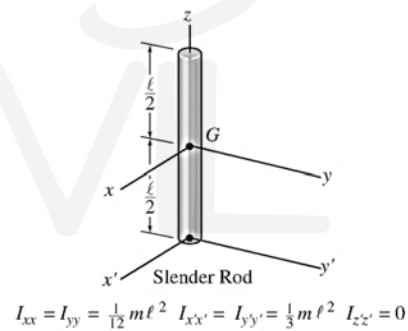
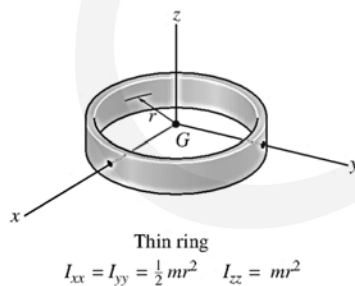
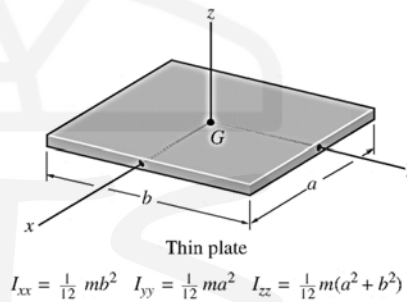
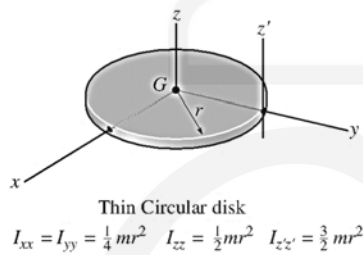
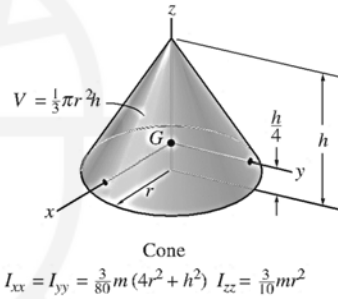
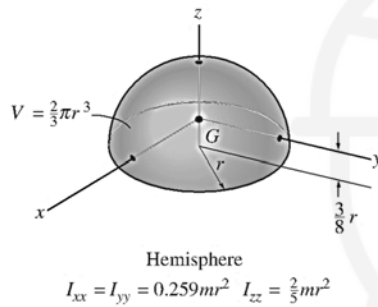
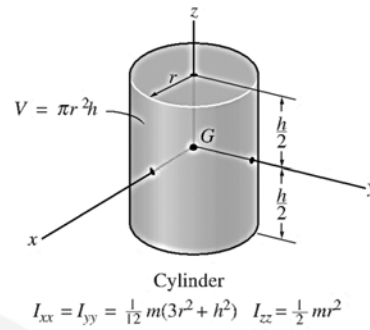
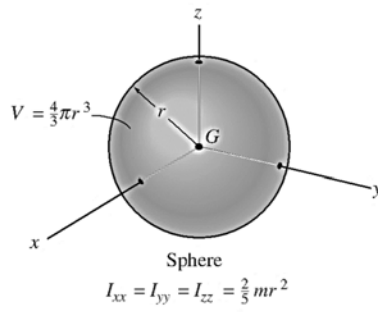

7.5 Fundamental Equations of Statics:

Cartesian Vector

$$\mathbf{A} = A_x \mathbf{i} + A_y \mathbf{j} + A_z \mathbf{k}$$

Magnitude

$$A = \sqrt{A_x^2 + A_y^2 + A_z^2}$$

Directions

$$\begin{aligned} \mathbf{u}_A &= \frac{\mathbf{A}}{A} = \frac{A_x}{A} \mathbf{i} + \frac{A_y}{A} \mathbf{j} + \frac{A_z}{A} \mathbf{k} \\ &= \cos \alpha \mathbf{i} + \cos \beta \mathbf{j} + \cos \gamma \mathbf{k} \\ \cos^2 \alpha + \cos^2 \beta + \cos^2 \gamma &= 1 \end{aligned}$$

Dot Product

$$\begin{aligned} \mathbf{A} \cdot \mathbf{B} &= AB \cos \theta \\ &= A_x B_x + A_y B_y + A_z B_z \end{aligned}$$

Cross Product

$$\mathbf{C} = \mathbf{A} \times \mathbf{B} = \begin{vmatrix} \mathbf{i} & \mathbf{j} & \mathbf{k} \\ A_x & A_y & A_z \\ B_x & B_y & B_z \end{vmatrix}$$

Cartesian Position Vector

$$\mathbf{r} = (x_2 - x_1) \mathbf{i} + (y_2 - y_1) \mathbf{j} + (z_2 - z_1) \mathbf{k}$$

Cartesian Force Vector

$$\mathbf{F} = F \mathbf{u} = F \left(\frac{\mathbf{r}}{r} \right)$$

Moment of a Force

$$\begin{aligned} M_o &= Fd \\ \mathbf{M}_o &= \mathbf{r} \times \mathbf{F} = \begin{vmatrix} \mathbf{i} & \mathbf{j} & \mathbf{k} \\ r_x & r_y & r_z \\ F_x & F_y & F_z \end{vmatrix} \end{aligned}$$

Moment of a Force About a Specified Axis

$$M_a = \mathbf{u} \cdot \mathbf{r} \times \mathbf{F} = \begin{vmatrix} u_x & u_y & u_z \\ r_x & r_y & r_z \\ F_x & F_y & F_z \end{vmatrix}$$

Simplification of a Force and Couple System

$$\begin{aligned} \mathbf{F}_R &= \Sigma \mathbf{F} \\ (\mathbf{M}_R)_O &= \Sigma \mathbf{M} + \Sigma \mathbf{M}_O \end{aligned}$$

Equilibrium

Particle

$$\Sigma F_x = 0, \Sigma F_y = 0, \Sigma F_z = 0$$

Rigid Body-Two Dimensions

$$\Sigma F_x = 0, \Sigma F_y = 0, \Sigma M_O = 0$$

Rigid Body-Three Dimensions

$$\begin{aligned} \Sigma F_x = 0, \Sigma F_y = 0, \Sigma F_z = 0 \\ \Sigma M_{x'} = 0, \Sigma M_{y'} = 0, \Sigma M_{z'} = 0 \end{aligned}$$

Friction

Static (maximum) $F_s = \mu_s N$

Kinetic $F_k = \mu_k N$

Center of Gravity

Particles or Discrete Parts

$$\bar{r} = \frac{\Sigma \tilde{r} W}{\Sigma W}$$

Body

$$\bar{r} = \frac{\int \tilde{r} dW}{\int dW}$$

Area and Mass Moments of Inertia

$$I = \int r^2 dA \quad I = \int r^2 dm$$

Parallel-Axis Theorem

$$I = \bar{I} + Ad^2 \quad I = \bar{I} + md^2$$

Radius of Gyration

$$k = \sqrt{\frac{I}{A}} \quad k = \sqrt{\frac{I}{m}}$$

Virtual Work

$$\delta U = 0$$

7.6 SI Prefixes:

<i>Multiple</i>	<i>Exponential Form</i>	<i>Prefix</i>	<i>SI Symbol</i>
1 000 000 000	10^9	giga	G
1 000 000	10^6	mega	M
1 000	10^3	kilo	k
<i>Submultiple</i>			
0.001	10^{-3}	milli	m
0.000 001	10^{-6}	micro	μ
0.000 000 001	10^{-9}	nano	n

7.7 Conversion Factors (FPS) to (SI)

<i>Quantity</i>	<i>Unit of Measurement (FPS)</i>	<i>Equals</i>	<i>Unit of Measurement (SI)</i>
Force	lb		4.448 N
Mass	slug		14.59 kg
Length	ft		0.3048 m

7.8 Conversion Factors (FPS):

$$1 \text{ ft} = 12 \text{ in. (inches)}$$

$$1 \text{ mi. (mile)} = 5280 \text{ ft}$$

$$1 \text{ kip (kilopound)} = 1000 \text{ lb}$$

$$1 \text{ ton} = 2000 \text{ lb}$$

7.9 Conversion Factors Table:

Conversion Factors					
Multiply	By	To Obtain	Multiply	By	To Obtain
acre	43560	square feet (ft ²)	joule (J)	9.478×10 ⁻⁴	Btu
ampere-hr (A-hr)	3600	coulomb (C)	J	0.7376	ft-lbf
ångström (Å)	1×10 ⁻¹⁰	meter (m)	J	1	newton-m (N-m)
atmosphere (atm)	76	cm, mercury (Hg)	J/s	1	watt (W)
atm, std	29.92 in	mercury (Hg)			
atm, std	14.7	lbf/in ² abs (psia)	kilogram (kg)	2.205	pound (lbm)
atm, std	33.9	ft, water	kgf	9.8066	newton (N)
atm, std	1.013×10 ⁵	pascal (Pa)	kilometer (km)	3281	feet (ft)
			km/hr	0.621	mph
bar	1×10 ⁵	Pa	kilopascal (kPa)	0.145	lbf/in ² (psi)
barrels-oil	42	gallons-oil	kilowatt (kW)	1.341	horsepower (hp)
Btu	1055	joule(J)	kW	3413	Btu/hr
Btu	2.928×10 ⁻⁴	kilowatt-hr (kWh)	kW	737.6	(ft-lbf)/sec
Btu	778	ft-lbf	kW-hour (kWh)	3413	Btu
Btu/hr	3.930×10 ⁻⁴	horsepower (hp)	kWh	1.341	hp-hr
Btu/hr	0.293	watt (W)	kWh	3.6×10 ⁶	joule (J)
Btu/hr	0.216	ft-lbf/sec	kip (K)	1000	lbf
			K	4448	newton (N)
calorie (g-cal)	3.968×10 ⁻³	Btu			
cal	1.560×10 ⁻⁶	hp-hr	liter (L)	61.02	in ³
cal	4.186	joule (J)	L	0.264	gal (US Liq)
cal/sec	4.186	watt (W)	L	10×10 ⁻³	m ³
centimeter (cm)	3.281×10 ⁻²	foot (ft)	L/second (L/s)	2.119	ft ³ /min (cfm)
cm	0.394	inch (in)	L/s	15.85	gal (US)/min (gpm)
centipoise (cP)	0.001	pascal-sec (Pa-s)			
centistokes (cSt)	1×10 ⁻⁶	m ² /sec (m ² /s)	meter (m)	3.281	feet (ft)
cubic feet/second (cfs)	0.646317	million gallons/day (mgd)	m	1.094	yard
cubic foot (ft ³)	7.481	gallon	metric ton	1000	kilogram (kg)
cubic meters (m ³)	1000	Liters	m/second (m/s)	196.8	feet/min (ft/min)
electronvolt (eV)	1.602×10 ⁻¹⁹	joule (J)	mile (statute)	5280	feet (ft)
			mile (statute)	1.609	kilometer (km)
foot (ft)	30.48	cm	mile/hour (mph)	88	ft/min (fpm)
ft	0.3048	meter (m)	mph	1.609	km/h
ft-pound (ft-lbf)	1.285×10 ⁻³	Btu	mm of Hg	1.316×10 ⁻³	atm
ft-lbf	3.766×10 ⁻⁷	kilowatt-hr (kWh)	mm of H ₂ O	9.678×10 ⁻⁵	atm
ft-lbf	0.324	calorie (g-cal)			
ft-lbf	1.356	joule (J)	newton (N)	0.225	lbf
ft-lbf/sec	1.818×10 ⁻³	horsepower (hp)	N-m	0.7376	ft-lbf
			N-m	1	joule (J)
gallon (US Liq)	3.785	liter (L)			
gallon (US Liq)	0.134	ft ³	pascal (Pa)	9.869×10 ⁻⁶	atmosphere (atm)
gallons of water	8.3453	pounds of water	Pa	1	newton/m ² (N/m ²)
gamma (γ, Γ)	1×10 ⁻⁹	tesla (T)	Pa-sec (Pa-s)	10	poise (P)
gauss	1×10 ⁻⁴	T	pound (lbm,avdp)	0.454	kilogram (kg)
gram (g)	2.205×10 ⁻³	pound (lbm)	lbf	4.448	N
			lbf-ft	1.356	N-m
hectare	1×10 ⁴	square meters (m ²)	lbf/in ² (psi)	0.068	atm
hectare	2.47104	acres	psi	2.307	ft of H ₂ O
horsepower (hp)	42.4	Btu/min	psi	2.036	in of Hg
hp	745.7	watt(W)	psi	6895	Pa
hp	33000	(ft-lbf)/min			
hp	550	(ft-lbf)/sec	radian	$\frac{180}{\pi}$	degree
hp-hr	2544	Btu			
hp-hr	1.98×10 ⁶	ft-lbf	stokes	1×10 ⁻⁴	m ² /s
hp-hr	2.68×10 ⁶	joule (J)			
hp-hr	0.746	kWh	therm	1×10 ⁵	Btu
inch (in)	2.54	centimeter (cm)	watt (W)	3.413	Btu/hr
in of Hg	0.0334	atm	W	1.341×10 ⁻³	horsepower (hp)
in of Hg	13.6	in of H ₂ O	W	1	joule/sec (J/s)
in of H ₂ O	0.0361	lbf/in ² (psi)	weber/m ² (Wb/m ²)	10000	gauss
in of H ₂ O	0.002458	atm			



7.10 Cheat Sheet:

Trigonometry:

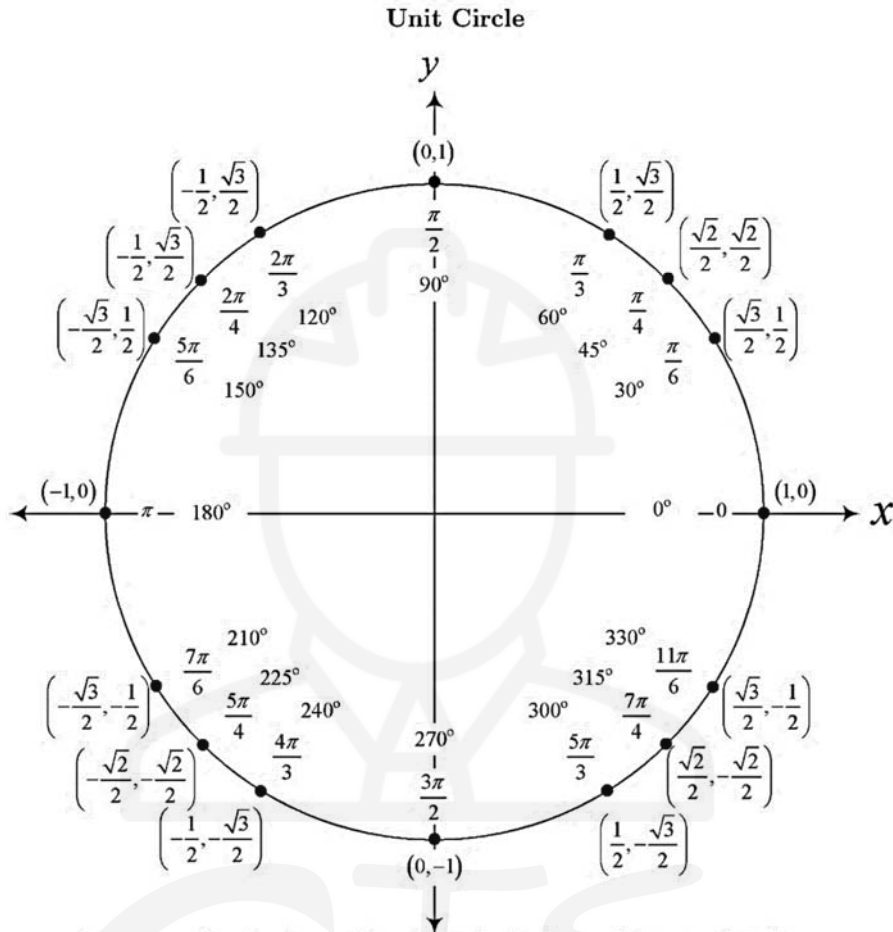

For any ordered pair on the unit circle (x,y) : $\cos \theta = x$ and $\sin \theta = y$

Degrees to Radians Formulas

If x is an angle in degrees and t is an angle in radians then

$$t = \frac{\pi x}{180} \quad \text{and} \quad x = \frac{180t}{\pi}$$

Right Triangle

For this definition we assume that $0 < \theta < \frac{\pi}{2}$ or $0^\circ < \theta < 90^\circ$

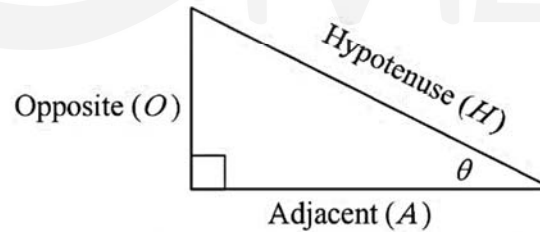

$$\sin(\theta) = \frac{O}{H} \quad \cos(\theta) = \frac{A}{H} \quad \tan(\theta) = \frac{O}{A}$$

$$\csc(\theta) = \frac{H}{O} \quad \sec(\theta) = \frac{H}{A} \quad \cot(\theta) = \frac{A}{O}$$

Reciprocal Identities

$$\begin{aligned} \sin(\theta) &= \frac{1}{\csc(\theta)} & \cos(\theta) &= \frac{1}{\sec(\theta)} & \tan(\theta) &= \frac{1}{\cot(\theta)} \\ \csc(\theta) &= \frac{1}{\sin(\theta)} & \sec(\theta) &= \frac{1}{\cos(\theta)} & \cot(\theta) &= \frac{1}{\tan(\theta)} \end{aligned}$$

Pythagorean Identities

$$\sin^2(\theta) + \cos^2(\theta) = 1 \quad \tan^2(\theta) + 1 = \sec^2(\theta) \quad \cot^2(\theta) + 1 = \csc^2(\theta)$$

Even/Odd Formulas

$$\begin{aligned} \sin(-\theta) &= -\sin(\theta) & \csc(-\theta) &= -\csc(\theta) \\ \cos(-\theta) &= \cos(\theta) & \sec(-\theta) &= \sec(\theta) \\ \tan(-\theta) &= -\tan(\theta) & \cot(-\theta) &= -\cot(\theta) \end{aligned}$$

Inverse Trig Functions

$$\begin{aligned} y = \sin^{-1}(x) & \text{ is equivalent to } x = \sin(y) \\ y = \cos^{-1}(x) & \text{ is equivalent to } x = \cos(y) \\ y = \tan^{-1}(x) & \text{ is equivalent to } x = \tan(y) \end{aligned}$$

Law of Sines, Cosines and Tangents

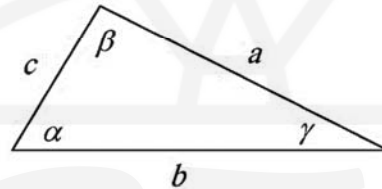

Law of Sines

$$\frac{\sin(\alpha)}{a} = \frac{\sin(\beta)}{b} = \frac{\sin(\gamma)}{c}$$

Law of Cosines

$$a^2 = b^2 + c^2 - 2bc \cos(\alpha) \quad b^2 = a^2 + c^2 - 2ac \cos(\beta) \quad c^2 = a^2 + b^2 - 2ab \cos(\gamma)$$

Law of Tangents

$$\frac{a-b}{a+b} = \frac{\tan \frac{1}{2}(\alpha-\beta)}{\tan \frac{1}{2}(\alpha+\beta)} \quad \frac{b-c}{b+c} = \frac{\tan \frac{1}{2}(\beta-\gamma)}{\tan \frac{1}{2}(\beta+\gamma)} \quad \frac{a-c}{a+c} = \frac{\tan \frac{1}{2}(\alpha-\gamma)}{\tan \frac{1}{2}(\alpha+\gamma)}$$

Mollweide's Formula

$$\frac{a+b}{c} = \frac{\cos \frac{1}{2}(\alpha - \beta)}{\sin \frac{1}{2}\gamma}$$

Similar Triangles

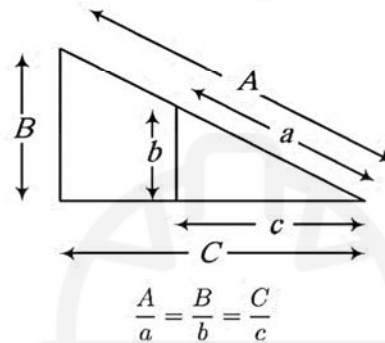

Algebra:

Arithmetic Operations

$$ab + ac = a(b + c) \quad a\left(\frac{b}{c}\right) = \frac{ab}{c}$$

$$\left(\frac{a}{b}\right) \frac{c}{c} = \frac{ac}{bc} \quad \frac{a}{\left(\frac{b}{c}\right)} = \frac{ac}{b}$$

$$\frac{a}{b} + \frac{c}{d} = \frac{ad + bc}{bd} \quad \frac{a}{b} - \frac{c}{d} = \frac{ad - bc}{bd}$$

$$\frac{a-b}{c-d} = \frac{b-a}{d-c} \quad \frac{a+b}{c} = \frac{a}{c} + \frac{b}{c}$$

$$\frac{ab + ac}{a} = b + c, \quad a \neq 0 \quad \left(\frac{\frac{a}{b}}{\frac{c}{d}}\right) = \frac{ad}{bc}$$

Exponent Properties

$$a^n a^m = a^{n+m} \quad \frac{a^n}{a^m} = a^{n-m} = \frac{1}{a^{m-n}}$$

$$(a^n)^m = a^{nm} \quad a^0 = 1, \quad a \neq 0$$

$$(ab)^n = a^n b^n \quad \left(\frac{a}{b}\right)^n = \frac{a^n}{b^n}$$

$$a^{-n} = \frac{1}{a^n} \quad \frac{1}{a^{-n}} = a^n$$

$$\left(\frac{a}{b}\right)^{-n} = \left(\frac{b}{a}\right)^n = \frac{a^n}{b^n} \quad a^{\frac{n}{m}} = \left(a^{\frac{1}{m}}\right)^n = (a^n)^{\frac{1}{m}}$$

Properties of Radicals

$$\sqrt[n]{a} = a^{\frac{1}{n}} \quad \sqrt[n]{ab} = \sqrt[n]{a} \sqrt[n]{b}$$

$$\sqrt[m]{\sqrt[n]{a}} = \sqrt[mn]{a} \quad \sqrt[n]{\frac{a}{b}} = \frac{\sqrt[n]{a}}{\sqrt[n]{b}}$$

$$\sqrt[n]{\sqrt[n]{a}} = a, \quad \text{if } n \text{ is odd} \quad \sqrt[n]{\sqrt[n]{a}} = |a|, \quad \text{if } n \text{ is even}$$

Distance Formula

If $P_1 = (x_1, y_1)$ and $P_2 = (x_2, y_2)$ are two points the distance between them is

$$d(P_1, P_2) = \sqrt{(x_2 - x_1)^2 + (y_2 - y_1)^2}$$

Logarithms and Log Properties**Definition**

$$y = \log_b x \text{ is equivalent to } x = b^y$$

Special Logarithms

$$\ln x = \log_e x \quad \text{natural log}$$

$$\log x = \log_{10} x \quad \text{common log} \quad \text{where } e = 2.718281828 \dots$$

Logarithm Properties

$$\log_b b = 1 \quad \log_b 1 = 0 \quad \log_b b^x = x \quad b^{\log_b x} = x$$

$$\log_b (x^r) = r \log_b x \quad \log_b (xy) = \log_b x + \log_b y \quad \log_b \left(\frac{x}{y} \right) = \log_b x - \log_b y$$

The domain of $\log_b x$ is $x > 0$

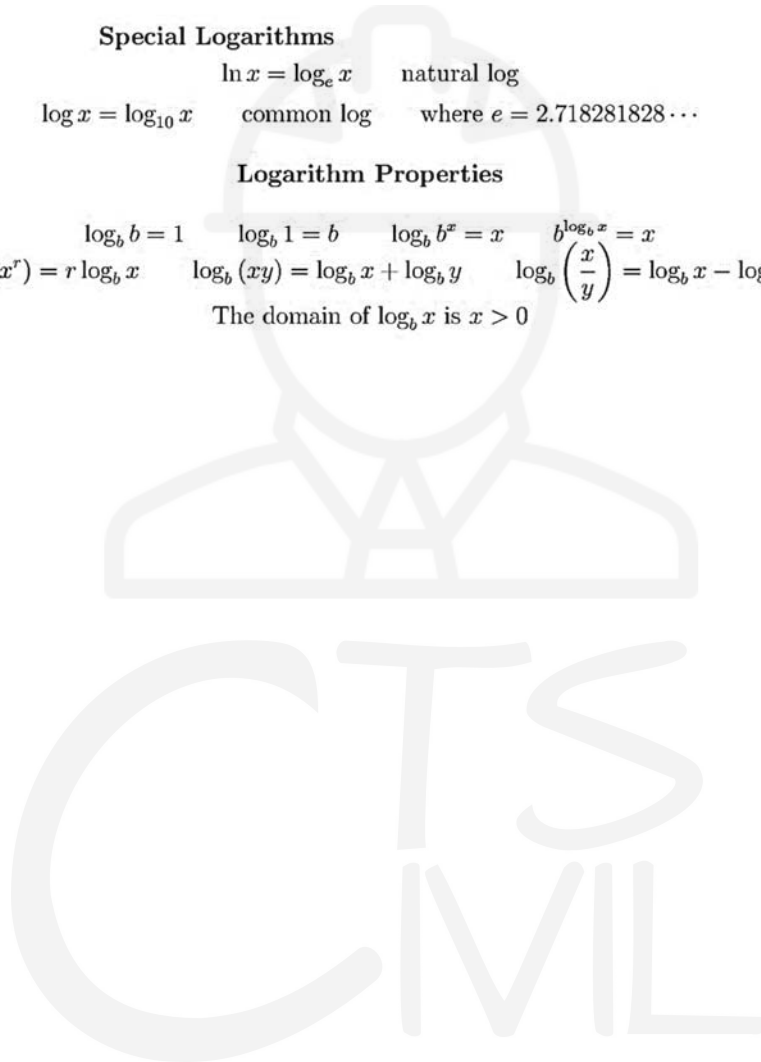

Glossary

Here is a simple glossary of some of the most used terminology in statics and structural analysis courses.

A

Abrupt	مفاجئ
Absolute	مطلق
Absolute Value	القيمة المطلقة
Absolute system of units	نظام الوحدات المطلقة
Acceleration	تسارع
Accuracy	دقة
Accurate	دقيق
Action	عمل / فعل
Active force	القوة الفعالة / القوة النشطة
Actual	فعلي
Addition	إضافة / جمع
Addition of forces	جمع القوى
Addition of vectors	جمع المتجهات
Adjacent vectors	المتجهات المجاورة
Advantage	أفضلية
Aerostatics	الإيروسستاتيكس / علم توازن الهواء و الغازات
Algebra	علم الجبر
Algebraic	جبري
Algebraic expression	تعبير جبري
Algebraic sum	جمع جبري
Allow	يسمح
Analysis	تحليل
Analytical	تحليلية
Analyze	تحليل
Anchor bolts	مرساة البراغي
Anemometers	أنيموميتر / جهاز قياس شدة الرياح
Angle	زاوية



Angular	زاوي / ذو علاقة بالزاوية
Answer	إجابة
Apex	ذروة
Application	تطبيق
Applied force	القوة المطبقة
Approximate	تقريبي
Arbitrary shapes	الأشكال العشوائية
Arches	أقواس
Area	مساحة
Area moments of inertia	عزم المساحة (عزم القصور الذاتي)
Area of cross-section	مساحة المقطع العرضي
Arm	ذراع
Arrow	سهم
Associative	ترابطي
Associative addition	الجمع الترابطي
Associative property	الخاصية الترابطية
Assume	افتراض
Assumption	افتراض
Atmospheric pressure	الضغط الجوي
Available	متاح
Average	معدل
Axes	محاور
Axial	محوري
B	
Balanced	متوازن
Bar	قضيب (معدني)
Barrel arches	أقواس ذات مقطع علوي شبه اسطواني
Base	قاعدة
Beam	كمر
Beam cross section	المقطع العرضي للكمرة

Cantilever beam	كمره معلقة (كابولي)
Deep beam	كمره عميقة
Overhanging beam	كمره المتدلية
Simply supported beam	كمره بسيطة
Bearing	تحمل / ضغط
Bearing friction	تحمل / ضغط الاحتكاك
Bearing stress	إجهاد التحمل / الضغط
Behavior	سلوك
Belt	حزام
Belt friction	حزام الاحتكاك
Belts and pulleys	أحزمة و بكرات
Bending	تقوس
Bending moment	عزم الانحناء
Bending moment diagram	الرسم البياني لعزم الانحناء
Bending rigidity	صلابة الانحناء
Bending stress	إجهاد الانحناء
Bernoulli's principle of virtual displacements	مبدأ برنولي للإزاحة الافتراضية
Body	الجسم
Body force	قوة الجسم
Body rotation	دوران الجسم
Bond	رابطة
Boundary	حدود
Boundary conditions	شروط / حالات الحدود
Braced frame	إطار غير قابل للتمايل (مثبت)
Bracing	تثبيت
Bridge	جسر
British system of units	النظام البريطاني للوحدات
Brittle	هش
Buckling	التواء
Buckling load	حمل الالتواء

Buckling moment	عزم الالتواء
Building	بناء
Building code	قانون البناء
Building materials	مواد بناء
Buoyancy	الطفو
C	
Cables	الكابلات
Calculus	حساب التفاضل والتكامل
Cambered beam	الكمرة المقوسة تصميمياً
Cantilever	ناتئ / بارز / (كابولي)
Capstan	رحوية
Cartesian	ديكارتي
Cartesian components	المكونات الديكارتية
Cartesian coordinates	الإحداثيات الديكارتية
Catenary	سلسال
Center	مركز
Center line	خط الوسط
Center of mass	مركز الكتلة
Center of pressure	مركز الضغط
Center of gravity	مركز الجاذبية
Centroid	مركز المساحة / الجسم
Centroidal axes	محور مركز المساحة / الجسم
Chord	وتر
Circle of friction	دائرة الاحتكاك
Circular	دائري
Circular area	مساحة دائرية
Circular sector	قطاع دائري
Circumference	محيط
Civil engineers	مهندس مدني
Clamps	مشابك

Classification	تصنيف
Clockwise	عقارب الساعة
Coefficient	مُعامل
Coefficient of friction	معامل الاحتكاك
Coincide	يتزامن
Collapse	انهدام
Collinear	على خط واحد
Column	عامود
Common	مشترك
Commutative property	خاصية التبديل
Compatible	متوافق
Complementary	مكمل
Component	مكون
Composite	مركب
Compound	مركب
Compound beam	كمر مركبة
Compound truss	جمالون مركب
Compression	ضغط
Computation	حساب
Computer analysis	تحليل باستخدام الحاسوب
Concave	مقعر
Concentrated	مركز
Concentrated force	قوة مركزة
Concentrated load	حمل مركز
Conceptual design	التصميم النظري
Concrete	الخرسانة
Concrete bridges	جسور خرسانية
Reinforced concrete	خرسانة مسلحة
Concurrent	بنفس الوقت
Concurrent force system	نظام القوة المتزامنة

Condition	شرط / حالة
Cone of friction	مخروط الاحتكاك
Conservative	متحفّظ
Conservation of energy states	حفظ حالات الطاقة
Conservative system	أنظمة متحفّظة
Constant	ثابت
Constant of gravitation	ثابت الجاذبية
Constrained	مقيدة
Constraint	قيود
Construction	أعمال بناء
Contact	اتصل / اتصال
Continuity	استمرارية
Continuous	مستمر
Convention	عُرف
Conversion	تحويلات
Convex	محدب
Coordinates	إحداثيات
Coordinate systems	نظم الإحداثيات
Coordinate transformation	تحول الإحداثيات
Coplanar	في نفس المسطح
Copper	نحاس
Corner	ركن
Corresponding	المقابلة
Corrosion	تآكل
Cosines	جيب التمام (cos)
Coulomb theory of friction	نظرية كولومب للاحتكاك
Counterclockwise	عكس عقارب الساعة
Couple	زوجان / مزدوج
Cover	غطاء
Crack	شرخ

Create	يُحدِث
Creep	زحف
Critical	حرج
Cross	عكس / ضرب
Cross bracing	تثبيت متعكس
Cross or vector product	حاصل الضرب المتجهي
Crush	سحق
Curvature	انحناء
Curve	منحنى
Customary units (U.S.)	الوحدات الأمريكية المتعارف عليها
Cutout	تم استقطاعه / جزء مقطوع من كل
Cylinder	اسطوانة

D

Dam	سد
Dampers	مخمدرات / لامتصاص الطاقة
Dead load	الحمل الميت
Debris impact load	حمولة تأثير الحطام
Deck truss	جمالون لحمل الأسطح
Deep	عميق
Definition	تعريف
Deflection	انحراف / هبوط
Deform	تشوه / تغير بالشكل
Deformable body	جسم مشوه
Deformation	تشويه
Degree	درجة
Degree of freedom (DOF)	درجة الحرية
Degree of redundancy	درجة التكرار
Degree of Statical indeterminacy	درجة عدم الثبات الاستاتيكي
Density	كثافة
Dependent	يعتمد على



Depth	عمق
Derivative	المشتقة
Derived units	الوحدات المشتقة
Design	تصميم
Determinacy	الاحتمية
Determinate	مُحدد / (استاتيكيًا)
Deviation	الانحراف
Diagonal	قطري
Diagram	رسم بياني / رسم
Diameter	قطر الدائرة
Deferential	تفاضلي
Differential element	عنصر التفاضلية
Differential equation	المعادلة التفاضلية
Dimension	بُعد
Dimensionless	عديم أبعاد
Direct	مباشرة
Direction	اتجاه
Disk friction	احتكاك القرص
Displacement	الإزاح
Distorted sketch	رسم مشوهة
Distribute	يوزع
Distributed loads	الأحمال الموزعة
Distribution	توزيع
Distribution factor (DF)	عامل التوزيع
Distributive laws	قوانين التوزيع
Distributive property	خاصية التوزيع
Divide	يقسم
Dot products	ضرب المتجهات عددياً
Double	مزدوج
Double integration	التكامل المزدوج

Draw	رسم
Dry friction	الاحتكاك الجاف
Ductile	قابل للسحب
Dummy load	حمل وهمي
Durable	متين
Dynamic	ديناميكي

E

Earthquake	زلزال
Eccentric	غير محوري
Edge	حافة
Effect	تأثير
Effective	فعال
Efficiency	كفاءة
Elastic	مرن
Electromagnetic forces	القوى الكهرومغناطيسية
Element	جزء
Elevations	الارتفاعات
Elongation	استطالة
Empirical formula	الصيغة التجريبية
Energy	طاقة
Engineering	هندسة
Engineering mechanics	الميكانيكا الهندسية
Equation	معادلة
Equilibrium	اتزان
Equilibrium equations	معادلات الاتزان
Equilibrium position	موضع الاتزان
Equivalent	مكافئ
Equivalent systems of forces	أنظمة مكافئة للقوى
Errors in computation	أخطاء في الحساب
Evaluation of design	تقييم التصميم

Exceed	يتجاوز
Expansion	توسيع
External	خارجي

F

Fabrication errors	أخطاء التصنيع
Factor	عامل
Factor of safety	عامل السلامة
Gust factor	عامل العاصفة
Impact factor	عامل التأثير
Reduction factor	عامل التخفيض
Failure	فشل
Feet (ft)	قدم (وحدة قياس)
Fibers	ألياف
Finite	محدود
Fink trusses	جمالون (نوع Fink)
First moment of area	العزم الأول للمساحة
First-order analysis	تحليل من الدرجة الأولى
Fixed	ثابت
Flat roofs	أسطح مستوية
Flexibility	المرونة
Flexible cables	الكابلات المرنة
Flexural stiffness	صلابة الانحناء
Flood loads	أحمال الفيضانات
Floor systems	أنظمة الأرضيات
Fluids	الموائع
Footing	قاعدة / أساس
Force	قوة القصور الذاتي
Formula	معادلة
Formulation of problems	صياغة المشاكل
Foundation	أساس



Frame	الإطار
Free	حر
Free-body diagrams (FBD)	مخططات الجسم الحر
Friction	احتكاك
Frictionless	عديم الاحتكاك
Function	دالة / تطبيق رياضي
G	
Gage pressure	سعة الضغط
Gaps	ثغرات
Gas	غاز
General	عام / (عكس خاص)
General loading	تحميل عام
Geometrically unstable structure	هيكل غير مستقر هندسيا
Girder	عارضة / كمره رئيسية عرضية
Global coordinate system	نظام الإحداثيات العالمية
Graphical	بياني / رسومي
Graphical representation	تمثيل رسومي
Graphical solutions	حلول رسومية
Gravitation	الجاذبية الأرضية
Gravitational potential energy	طاقة الجاذبية الكامنة
Gravity	الجاذبية
Gyration	دوران / التفاف
H	
Hard	صعب / صلب
Height	ارتفاع
High	مرتفع
High-strength steel wires	أسلاك الفولاذ عالية القوة
Highway bridges	جسور الطريق السريع
Hinge	مفصل
Hollow	أجوف

Homogenous	متجانس
Hooke's law	قانون هوك
Horizontal	أفقي
Horsepower (hp)	حصان (وحدة قياس)
Hour (h)	ساعة (وحدة قياس)
Howe truss	جمالون (نوع Howe)
Hydraulics	علم السوائل المتحركة / هيدروليكا
Hydrostatics	علم الهيدروستاتيكا
Hydrostatic loads	الأحمال الهيدروستاتيكية
Hydrostatic pressure	الضغط الهيدروليكي
I	
I-beams	كمره بمقطع حرف ال I
Idealizing structures	هياكل مثالية
Identical	مطابق
Imaginary	خيالي
Impact factor	عامل التأثير
Impeding	وشيك
Impending motion	حركة وشيكة
Impending slip	انزلاق وشيك
Improper	غير سليم / غير لائق
Improper constraints	القيود غير السليمة
Improper supports	الدعامات غير السليمة
Inclined	مائل
Indeterminate	غير محدد
Inelastic behavior	سلوك غير مرن
Inertia force	قوة القصور الذاتي
Infinity	ملا نهاية
Inflection	التواء / انثناء / تغيير مسار
Influence area	منطقة التأثير
In-plane	في نفس المسطح الهندسي

Integration	تكاملي رقمي
Intermediate	متوسط
Internal	داخلي
International	دولي
International Code Council	مجلس القانون الدولي
International System of units (SI units)	النظام الدولي للوحدات
Isolate	يعزل
J	
Joint	فضالة / مفصل
Joule	جول (وحدة طاقة)
K	
K truss	جمالون (نوع K)
Kilo-	كيلو (1000 وحدة)
Kilogram (kg)	كيلوغرام (وحدة قياس)
Kilometer (km)	الكيلومتر (وحدة قياس)
Kilonewtons (kN)	كيلونيوتونات (وحدة قياس)
Kilopound (kip)	كيلوباوند (وحدة قياس)
Kinetic energy	الطاقة الحركية
L	
Lateral bracing	ربط / تدعيم جانبي
Law	قانون
Law of cosines	قانون (cosines)
Law of sines	قانون (sines)
Laws of motion	قوانين الحركة
Length	الطول
Level	مستوى
Limit	حد
Line	خط
Line of action	خط العمل / خط تأثير القوى

Linear	خطي
Link	حلقة وصل
Liquids	السوائل
Loads	أحمال
Dead loads	الأحمال الميتة
Earthquake loads	أحمال الزلازل
Flood loads	أحمال الفيضانات
Live loads	الأحمال الحية
Rain loads	أحمال الأمطار
Roof loads	أحمال الأسطح
Snow loads	أحمال الثلوج
Wind loads	أحمال الرياح
Load intensity	كثافة / شدة الحمل
Loading conditions	حالات التحميل
Loading curve	منحنى التحميل
Local coordinate system	نظام الإحداثيات المحلية
Longitudinal fibers	الألياف الطولية
Low-rise buildings	مباني منخفضة الارتفاع
M	
Machines	آلات
Magnitude	قيمة
Mass	كتلة
Material	مادة
Mathematics	الرياضيات
Mathematical model	نموذج رياضي
Matrix	مصفوفة
Maximum	أقصى
Mechanical efficiency	الكفاءة الميكانيكية
Mechanics	علم الميكانيكا
Mechanism	آلية

Mega gram (Mg)	ميغرام (وحدة قياس)
Member	عضو / عنصر
Member coordinate system	نظام الإحداثيات للعناصر / للأعضاء
Member stiffness	صلابة الأعضاء
Meter (m)	متر (وحدة قياس)
Method	طريقة
Metric	مترى
Middle	وسط
Mild steel	الفولاذ الطري
Mile (mi)	ميل (وحدة قياس)
Minimum	الحد الأدنى
Minute (min)	دقيقة (وحدة قياس)
Modulus	معامل
Modulus of elasticity	معامل المرونة
Young's modulus	معامل يونج
Mohr s circle	دائرة (Mohr)
Moment	عزم
Motion	حركة وشبكة
Multi-force members	عناصر متعددة القوى
N	
Negative	سلبى
Neutral	محايد
Neutral axis	المحور المحايد
Neutral plane	المسطح المحايد
Newton (N)	نيوتن (وحدة قياس)
Newton's law of gravitation	قانون نيوتن للجاذبية
Newton's three fundamental laws	قوانين نيوتن الثلاثة الأساسية
Nonlinear	غير الخطية
Normal force	قوى طبيعية
Notations	الترميزات / الرموز

Numerical	عددي / رقمي
Numerical Analysis	تحليل رقمي
Numerical integration	تكامل رقمي

O

Object	جسم
One-story building	مبنى من طابق واحد
Opposite	مقابل / عكس
Ordinate	الإحداثي الصادي (ص) لنقطة
Origin	الأصل
Original	أصلي

P

Parallel	موازي
Parallelogram	متوازي الاضلاع
Partial constraints	قيود جزئية
Particle	جسيم
Pascals (Pa)	باسكالز (وحدة قياس)
Passing a section	يمر خلال مقطع
Perimeter	محيط
Permanent	دائم
Perpendicular	عمودي
Pin-support	دعامة (Pin)
Plane	مستوى / مسطح
Planar	ذو مستوى / ذو مسطح
Point	نقطة
Point of application	نقطة التطبيق
Point of inflection	نقطة التواء / تغير المسار / تغير التقوس
Polygon	المضلع
Position	موضع
Possible	ممکن
Potential energy	الطاقة الكامنة

Pound (lb)	جنيه (وحدة قياس)
Practical	عملي
Pratt truss	جمالون نوع (Pratt)
Prefixes	البادئات
Pressure	الضغط
Pressure distribution	توزيع الضغط
Pressure intensity	شدة الضغط
Primary moment	عزم أساسي
Principal axes	المحاور الرئيسية
Principle	مبدأ
Product	حاصل الضرب
Projection	إسقاط
Properties of areas	خصائص المساحات
Proportion	نسبة
Proportional limit	الحد النسبي
Pulleys	البكرات
Pure bending	العزم النقي
Pythagorean theorem	نظرية فيثاغورث
Q	
Quality	جودة
Quantity	كمية
R	
Radian	راديان (وحدة قياس)
Radius	نصف القطر
Range	نطاق
Ratio	نسبة
Reaction	رد فعل
Real work	العمل الحقيقي / الفعلي
Rectangular components	المكونات المستطيلة للمتجه
Reduction factor	عامل التخفيض

Redundant	زائد عن الحاجة / متوفر
Redundancy	وفرة
Redundant supports	دعم زائدة عن الحاجة
Reinforced concrete	خرسانة مسلحة
Relationship	صلة
Relative	نسبيا
Resistance	مقاومة
Resolution	تحليل
Result	نتيجة
Resultant	محصلة
Revolution	دوران
Right	عامودي / قائم
Right triangle	مثلث قائم
Right-hand rule	قاعدة اليد اليمنى
Right-handed coordinate system	نظام إحداثيات اليد اليمنى
Rigid	جامد
Rivet	برشام
Roof	سقف
Rotate	يدور
Rotated axes	محاور تم استدارتها
Rotation	دوران
Rough surfaces	الأسطح الخشنة
Rounding off	التقريب
Rule	قاعدة / قانون

S

Safe	آمن
Scalar	عددي / رقمي
Scale	مقياس
Screw	برغي
Second (s)	الثانية (وحدة قياس)



Section	جزء
Semicircular area	منطقة نصف دائرية
Sense	إحساس
Series	سلسلة / متتالية
Service loads	أحمال خدمتية
Shear	قص
Shear force	قوة القص
Shear force diagram	مخطط قوة القص
Shear stress	إجهاد القص
Side-sway	التمايل الجانبي
Sign conventions	توقيع الانفاقيات
Similar	مماثل
Simple support	دعامة بسيطة
Slender	نحيل
Slip	انزلاق
Slope	ميل
Smooth surfaces	الأسطح الملساء
Solution	حل
Space	الفراغ / فضاء
Span	امتداد
Specific weight	الوزن المحدد
Spherical domes	قبة كروية
Spring	زنبرك
Spring constant	ثابت الزنبرك
Stable	مستقر
Static	ثابت / ساكن
Static equilibrium equations	معادلات التوازن الساكنة
Static friction	الاحتكاك الساكن
Statically determinate	محدد استاتيكيًا
Statically equivalent set	مجموعة مكافئة الستاتيكيًا

Statically indeterminate	غير محدد استاتيكيًا
Static-friction force	قوة الاحتكاك الثابت
Statics	علم الثوابت / السكون / الأجسام الساكنة
Stationary	ثابت
Stiffness	صلادة
Strategies	استراتيجيات
Strength	قوة
Stress	إجهاد
Bearing stress	إجهاد التحمل / الضغط
Normal stress	الإجهاد العمودي
Shear stress	إجهاد القص
Stretch	تمتد
Structural analysis	تحليل إنشائي
Structure	هيكل / منشأ
Subtraction	طرح
Sufficient conditions	ظروف كافية
Summary	ملخص
Superposition	تراكب
Super-positioned forces	قوى متراكبة
Super-positioned loads	أحمال متراكبة
Superimposing displacements	إزاحات متراكبة
Support	الدعم / دعامة
Fixed	ثابت / مرتكز
Hinged	فصالة
Roller	منزلق / قابل للانزلاق أفقيًا
Surface force	قوة السطح
Suspended cables	الكابلات المعلقة
Symbol	رمز
Symmetry	تناظر
System	النظام

T

Table	جدول / طاولة
Tangential	تماسي
Taylor series	متتالية تايلور
Temperature variation	تباين درجة الحرارة
Tension	شد
Test	اختبار
Theory	نظرية
Thickness	سماعة
Thin plates	لوحات رقيقة
Time	زمن / وقت
Ton (t)	طن (وحدة قياس)
Torque	عزم الدوران
Torsion	التواء
Translation	حركة / انتقال
Trapezoid	شبه منحرف
Triangle	مثلث
Triangle law	قانون المثلث
Tributary areas	المناطق الرافدة
Trigonometry	علم المثلثات
Truss	جمالون
Deck truss	جمالون لحمل الأسطح
Fink truss	جمالون (نوع Fink)
Howe truss	جمالون (نوع Howe)
K truss	جمالون (نوع K)
Pratt truss	جمالون (نوع Pratt)
Vierendeel truss	جمالون (نوع Vierendeel)
Warren truss	جمالون (نوع Warren)
Tsunami	تسونامي
Tube	إنبوب



U

Ultimate	أقصى
Unbalanced moment (UM)	عزم غير متوازن
Underestimate	يقلل من شأن
Uniformly distributed load	الحمل الموزع بشكل موحد
Unit	وحدة
Universal gravitational constant	ثابت الجاذبية العالمي
Unknowns	المجهيل
Unstable	غير مستقر

V

Value	قيمة
Variable	متغير
Vector	متجه
Velocity	السرعة
Vertical	عمودي
Vierendeel truss	جمالون (نوع Vierendeel)
Virtual	افتراضي / غير واقعي
Volume	حجم

W

Warren truss	جمالون (نوع Warren)
Watt (W)	واط (وحدة قياس)
Wave	موجة
Wedge	وتد
Weight	وزن
Welding	لحام
Wheel friction	احتكاك العجلة
Width	عرض
Winches	الروافع
Wind	رياح



Wires	الأسلاك
Work	عمل
Wrench	مفتاح الربط

Y

Yield	خضوع
Yield strain	انفعال الخضوع
Yield stress	إجهاد الخضوع
Young's modulus	معامل يونج

Z

Zero-force members	العناصر ذات القوى الصفيرية
--------------------	----------------------------